



PETA PROSES BISNIS

UNIVERSITAS NEGERI SEMARANG

TAHUN 2022



KATA PENGANTAR

Teriring dengan rasa syukur kepada Tuhan Yang Maha Kuasa, atas tersusunnya Peta Proses Bisnis Universitas Negeri Semarang (UNNES) tahun 2022 dapat diselesaikan dengan baik. Peta Proses Bisnis ini merupakan dokumen revisi atas Peta Proses Bisnis yang pernah disusun pada tahun 2019.

Dengan tersusunnya Peta Proses Bisnis, UNNES dapat memvisualisasi dari rangkaian seluruh aktivitas di dalam UNNES, yang mendemonstrasikan bagaimana pekerjaan dilakukan, sehingga menjadikan pelaksanaan pekerjaan tergambar dengan jelas/eksplisit. Dengan pemetaan proses bisnis ini UNNES memiliki dokumentasi tentang pekerjaan yang dilakukan, sehingga memungkinkan untuk menganalisa pekerjaan yang telah dilakukan dalam rangka peningkatan kualitas pelayanan dan kepuasan pelanggan melalui identifikasi terhadap proses, dan produktivitas, serta memudahkan pengukuran performansi.

Proses penyusunan peta proses bisnis dimulai dengan menggambarkan seluruh aktivitas yang terjadi pada kelompok besar layanan sesuai tugas dan fungsi UNNES yaitu mengelompokkan layanan inti dan layanan pendukung. Dari peta proses bisnis ini kemudian dapat didetailkan menjadi sub peta proses bisnis dan kemudian menjadi SOP. Dengan adanya SOP dapat diketahui bagaimana tata cara suatu proses pelayanan yang tuntas norma dan kriteria yang menjelaskan bagaimana, siapa, dan hasil apa yang diwujudkan dalam rangkaian aktivitas tersebut yang melibatkan lintas fungsi baik pada layanan inti dan layanan pendukung di dalam UNNES.

Kami menyampaikan terima kasih kepada tim yang telah menyelesaikan penyusunan dokumen peta proses bisnis UNNES, semoga dengan adanya dokumen ini dapat dipergunakan dan dimanfaatkan dalam meningkatkan kualitas pelaksanaan tugas dan fungsi UNNES sebagai institusi yang menyelenggarakan Tri Dharma Perguruan Tinggi.

1 Oktober 2022

a.n. Rektor,
Wakil Rektor Bidang Umum dan Keuangan,

TTD

Prof. Dr. S Martono, M.Si.
NIP 196603081989011001

GAMBARAN UMUM PETA PROSES BISNIS

Universitas Negeri Semarang (UNNES) merupakan perguruan tinggi negeri yang menerapkan pada pengelolaan badan layanan umum, berada dan bertanggungjawab kepada Menteri Pendidikan, Kebudayaan, Riset dan Teknologi, yang mempunyai tugas utama menyelenggarakan Tri Dharma Perguruan Tinggi. Untuk mendukung kegiatan utama tersebut, UNNES juga melaksanakan pembinaan civitas akademika dan hubungannya dengan lingkungan serta pelaksanaan kegiatan layanan administratif.

Dalam melaksanakan tugas dan fungsi, Perguruan Tinggi diwajibkan untuk Menyusun peta proses bisnis yang menggambarkan tata hubungan kerja yang efektif dan efisien antar unit organisasi dilingkungan Perguruan Tinggi. Tugas dan fungsi UNNES tersebut di gambarkan melalui layanan inti dan layanan pendukung. Layanan inti merupakan serangkaian aktivitas lintas fungsi (*cross function*) untuk melaksanakan bagian dari kegiatan bisnis/organisasi untuk mencapai tujuan tertentu. Sedangkan layanan pendukung merupakan proses yang mendukung proses inti dalam mengendalikan atau mengelola operasional dari suatu sistem dan memastikan proses inti dapat berjalan dengan baik.

Layanan inti UNNES yang dilaksanakan oleh UNNES meliputi : a) Layanan Pendidikan; b) Layanan Penelitian; c) Layanan Pengabdian Kepada Masyarakat. Sedangkan layanan pendukung yang dilaksanakan oleh UNNES meliputi : a) Layanan Akademik , Kemahasiswaan dan Kerjasama; b) Layanan Umum Hukum dan Kepegawaian; c) Layanan Perencanaan dan Keuangan; d) Layanan Perpustakaan; e) Layanan Teknologi, Informasi dan Komunikasi; f) Layanan Pengembangan Konservasi; g) Layanan Kearsipan; h) Layanan Hubungan Masyarakat; i) Layanan Urusan Tata Usaha Fakultas/Pascasarjana; j) Layanan Urusan Administrasi Lembaga; k) Layanan Penjaminan Mutu; l) Layanan Pengembang Bisnis; m) Layanan ULT (Unit Layanan Terpadu). Layanan inti dapat dilihat pada halaman 1 sampai dengan 27. Sedangkan layanan pendukung dapat dilihat pada halaman 28 sampai dengan 469.

DAFTAR ISI

HALAMAN JUDUL	i
KATA PENGANTAR	ii
DAFTAR ISI	iii
GAMBARAN UMUM PETA PROSES BISNIS	iv
LAYANAN INTI	1
1. Layanan Pendidikan	2
a. Layanan Proses Belajar Mengajar	2
b. Layanan Praktik Mahasiswa	16
2. Layanan Penelitian	19
a. Layanan Peneltian Dosen	19
b. Layanan Penelitian Mahasiswa	20
c. Layanan Luaran Penelitian	21
3. Layanan Pengabdian Kepada Masyarakat	25
a. Layanan Pengabdian Dosen	25
b. Layanan Pengabdian Mahasiswa	26
LAYANAN PENDUKUNG	28
1. Layanan Akademik, Kemahasiswaan dan Kerjasama	28
a. Layanan Akademik	28
b. Layanan Kemahasiswaan	60
c. Layanan Kerjasama	69
2. Layanan Umum Hukum dan Kepegawaian	84
a. Layanan Umum	84
b. Layanan Hukum dan Kepegawaian	100
3. Layanan Perencanaan dan Keuangan	142
a. Layanan Perencanaan	142
b. Layanan Keuangan	179
c. Layanan Akuntansi	209
4. Layanan Perpustakaan	237
5. Layanan Teknologi, Informasi dan Komunikasi	244
6. Layanan Pengembangan Konservasi	264
7. Layanan Kearsipan	281
8. Layanan Hubungan Masyarakat	294
9. Layanan Urusan Tata Usaha Fakultas/Pascasarjana	303
a. Layanan Akademik dan Kemahasiswaan	304
b. Layanan Keuangan	327
c. Layanan Akuntansi	337
d. Layanan Umum dan Kepegawaian	345
10. Layanan Urusan Administrasi Lembaga	368
a. Layanan LP3	368
b. Layanan LPPM	408
11. Layanan Penjaminan Mutu	418
12. Layanan Pengembang Bisnis	434
13. Layanan ULT (Unit Layanan Terpadu)	443

Level 0 UNNES

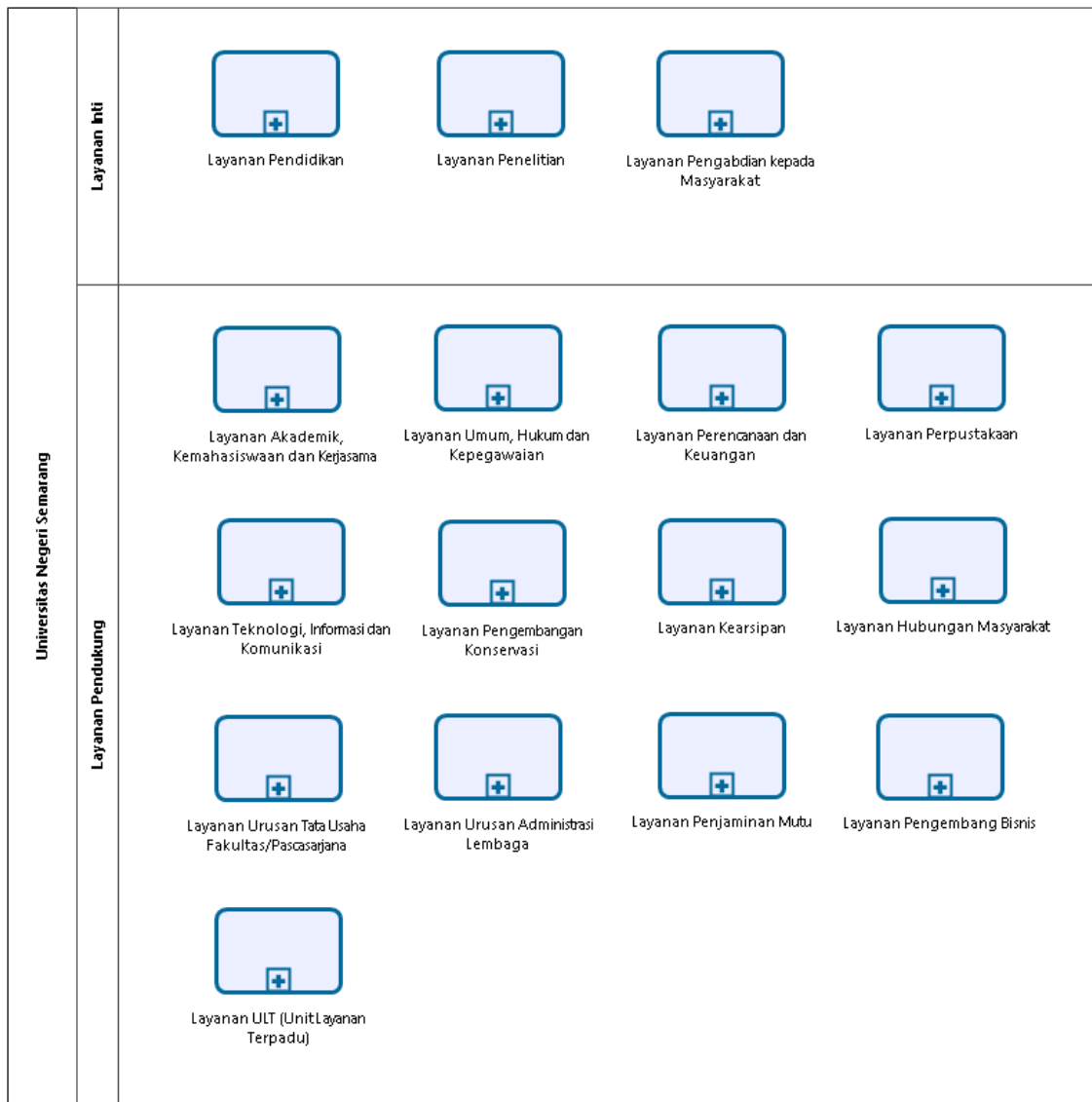

Level 1 Layanan Pendidikan

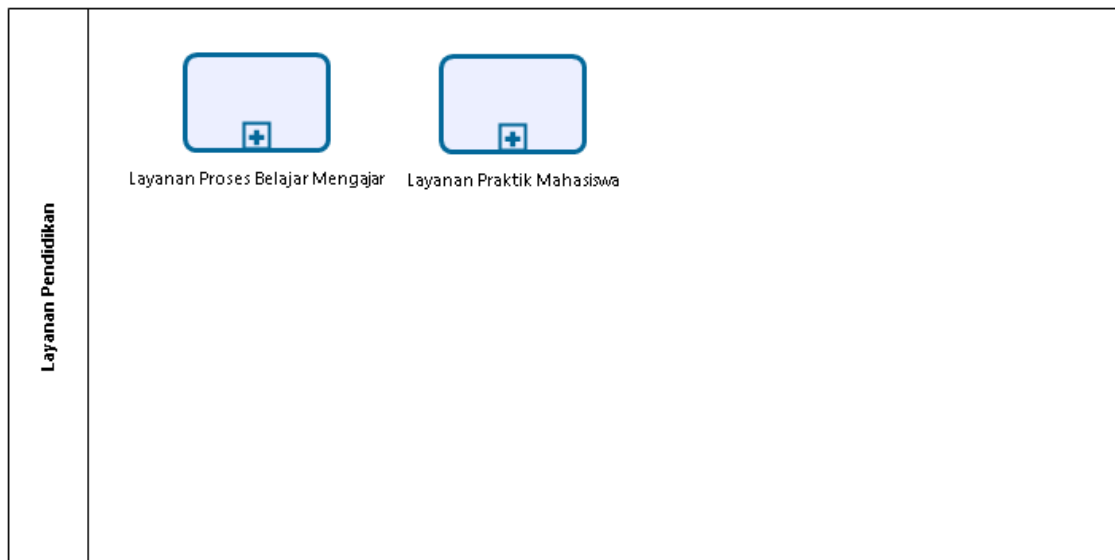

Powered by
bizagi
Modeler

Level 2 Layanan Proses Belajar Mengajar

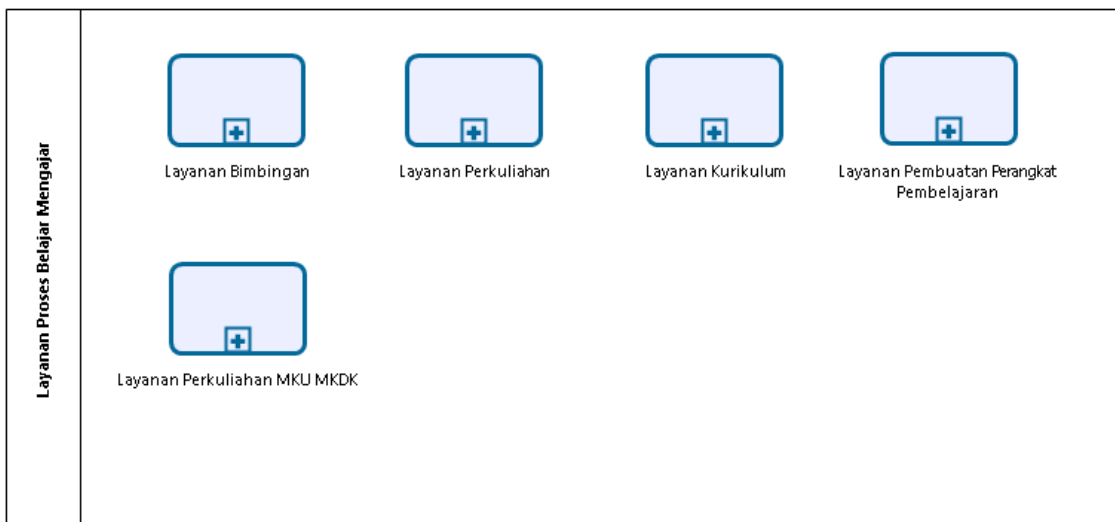

Powered by
bizagi
Modeler

Level 3 Layanan Bimbingan

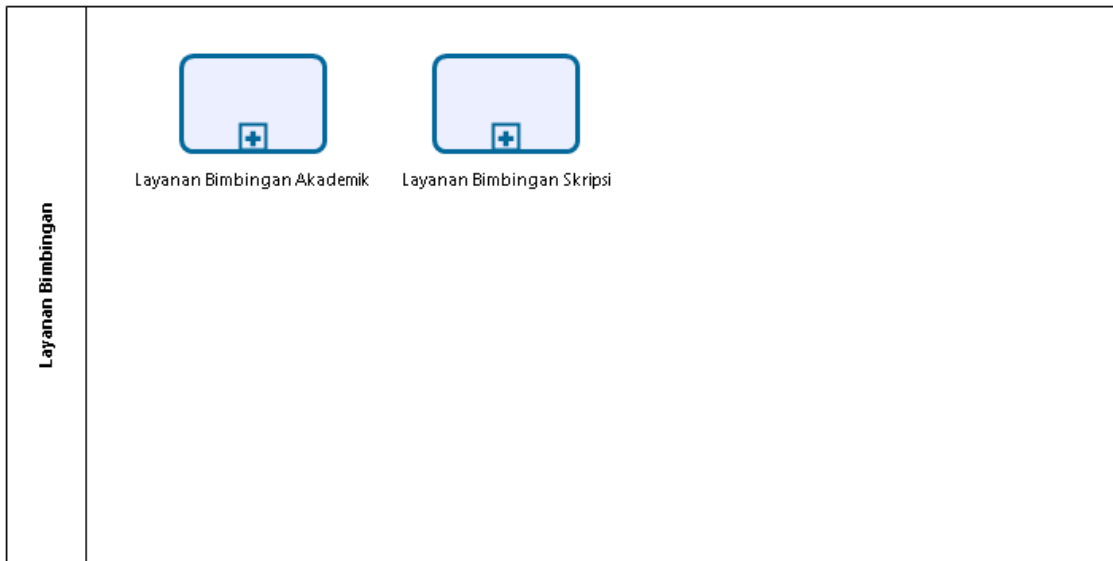

Level 4 Layanan Bimbingan Akademik

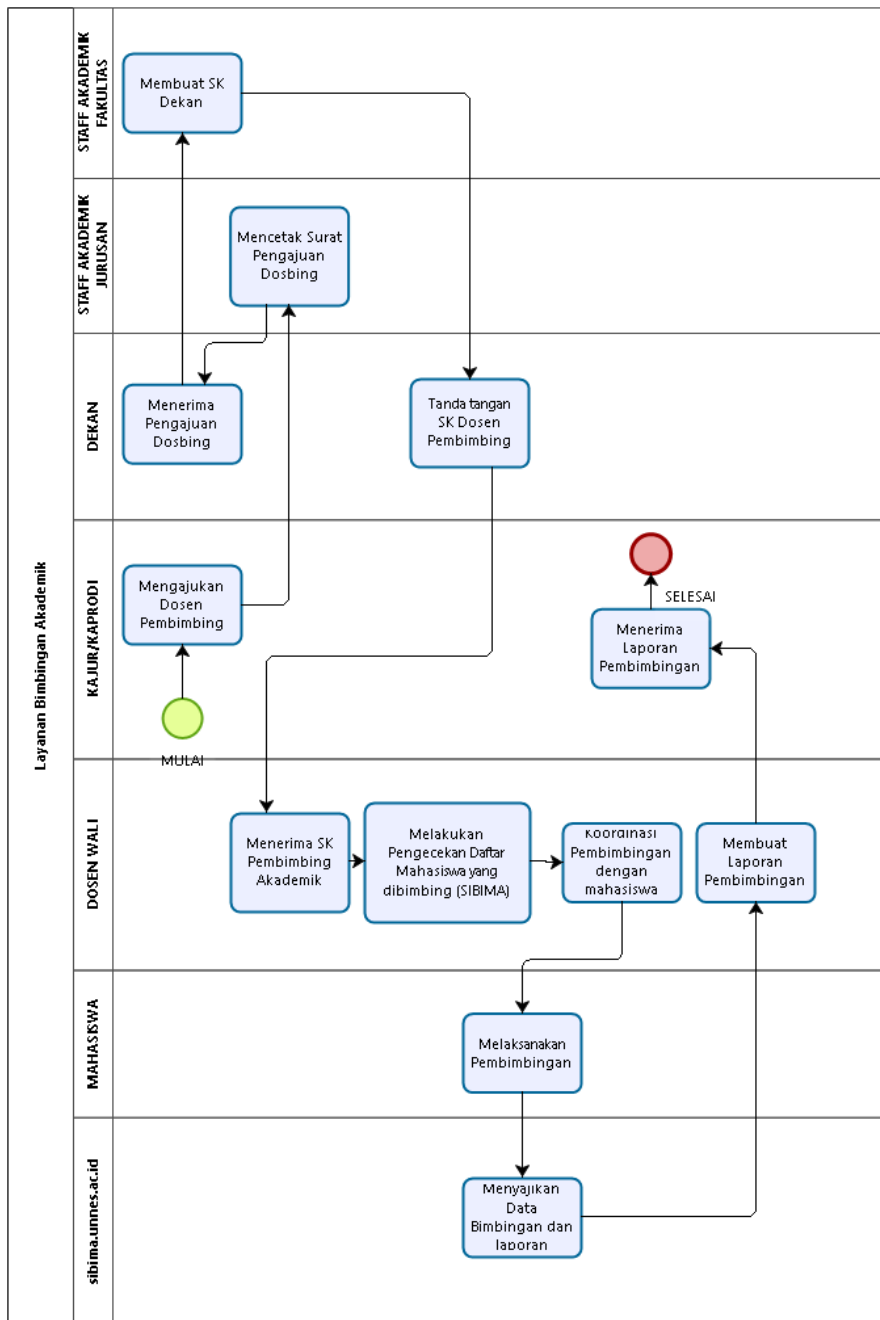

Level 4 Layanan Bimbingan Skripsi

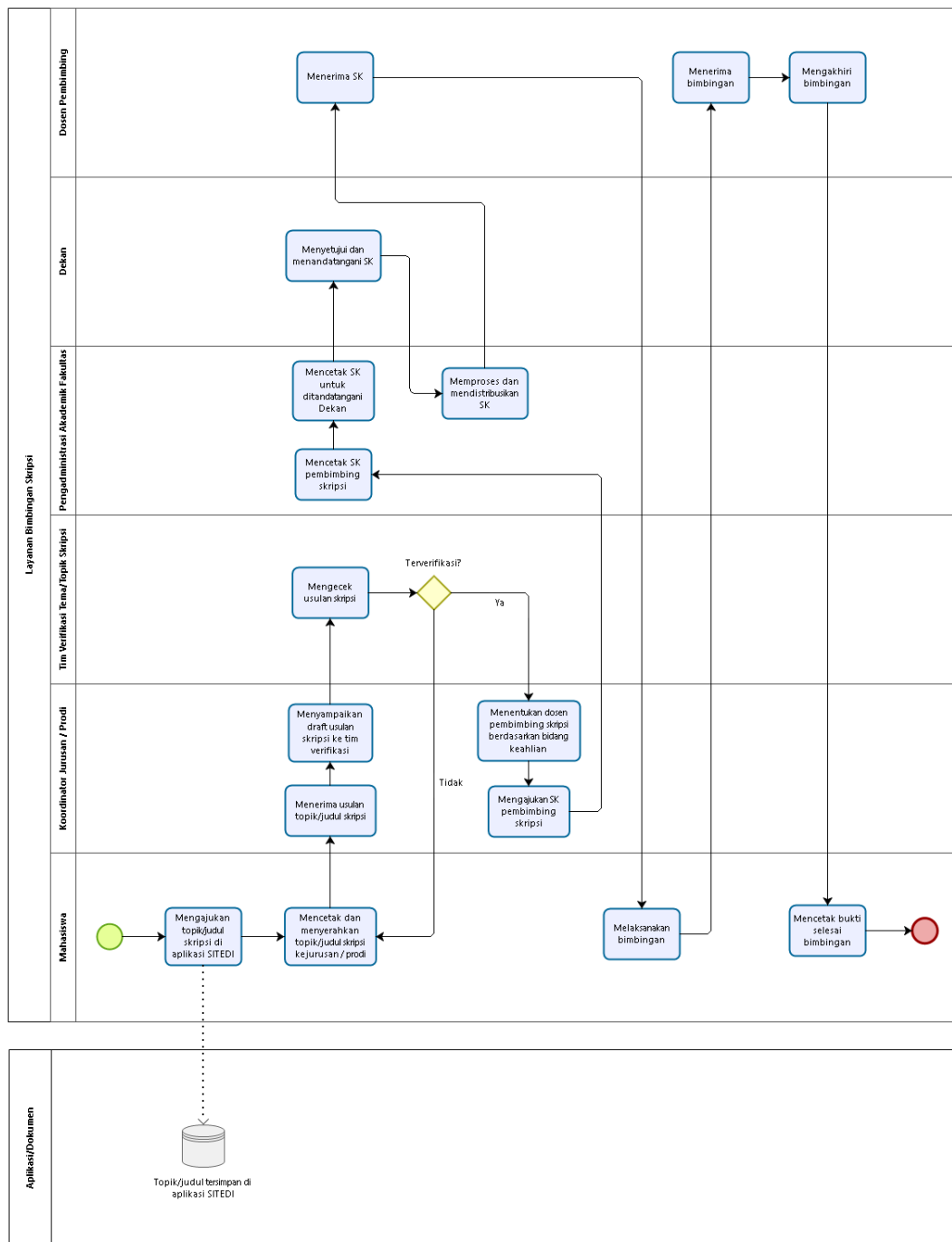

Level 3 Layanan Perkuliahan

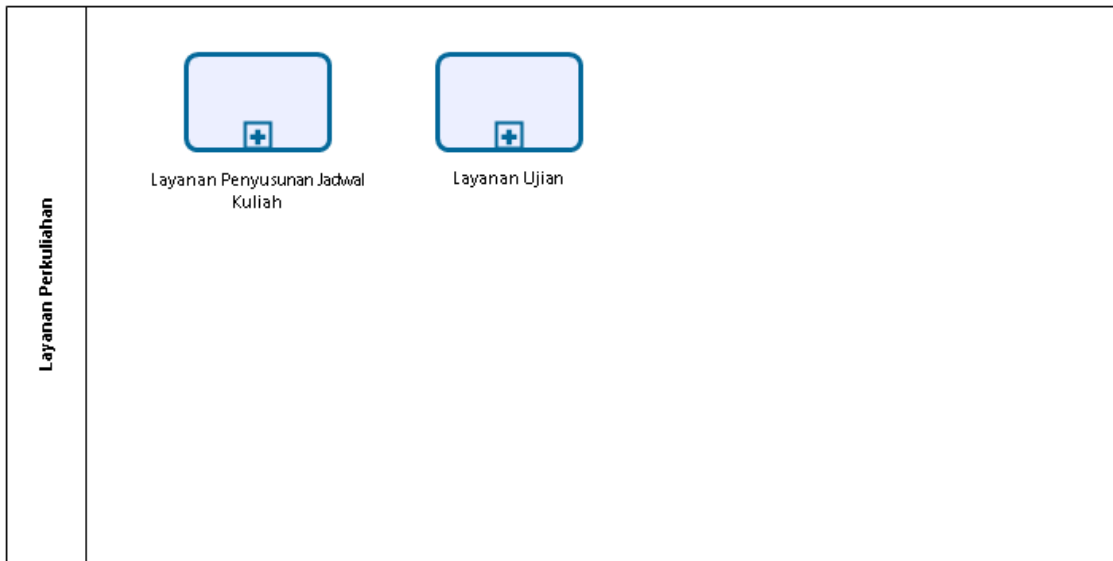

Powered by
bizagi
Modeler

Level 4 Layanan Penyusunan Jadwal Kuliah

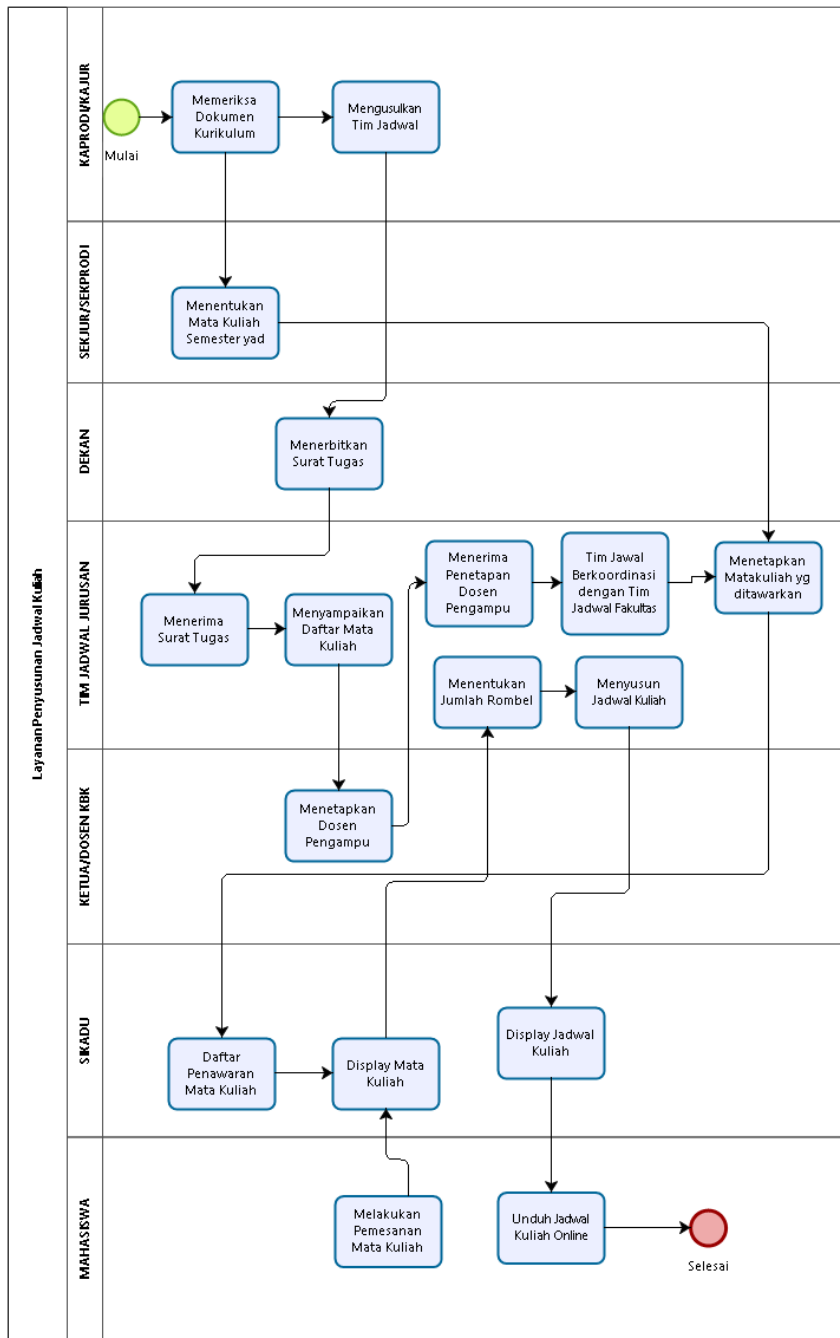

Level 4 Layanan Ujian

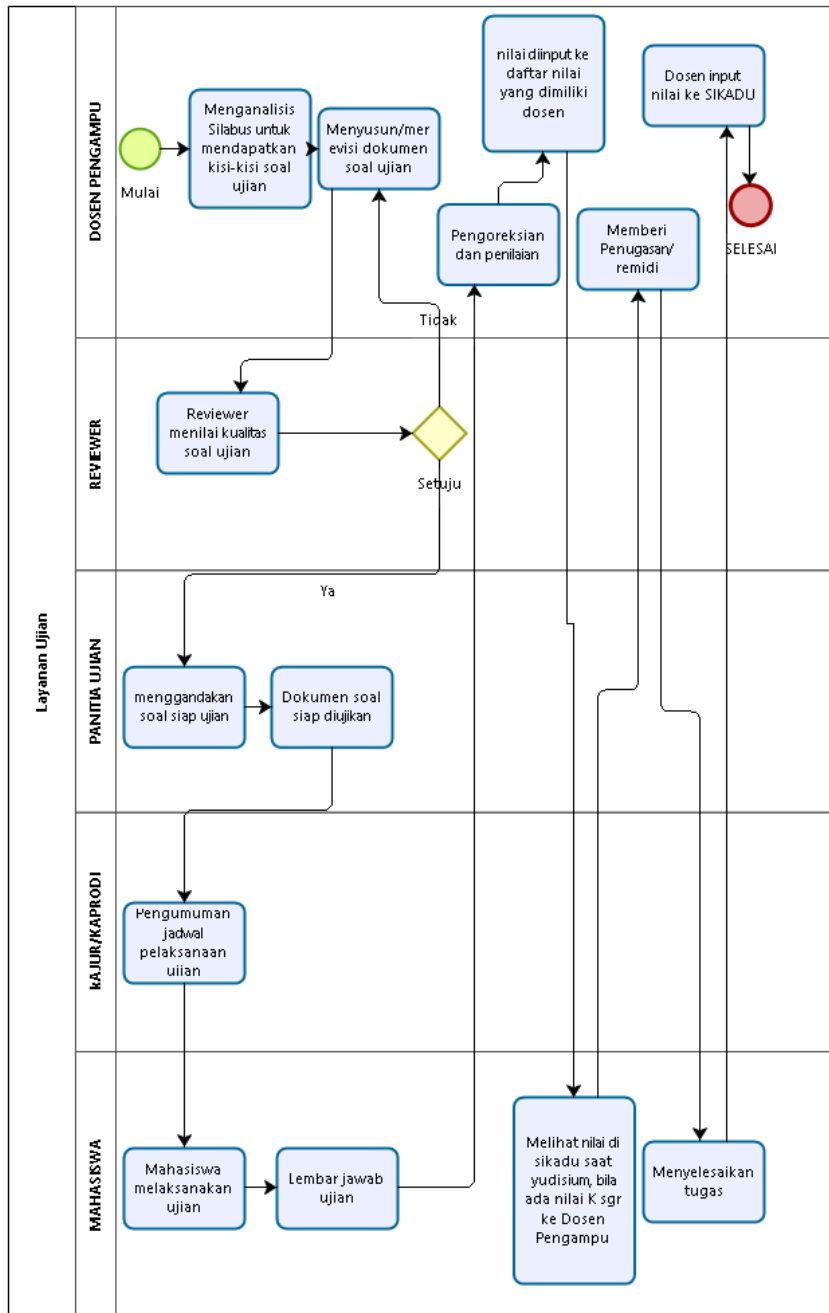

Level 3 Layanan Kurikulum

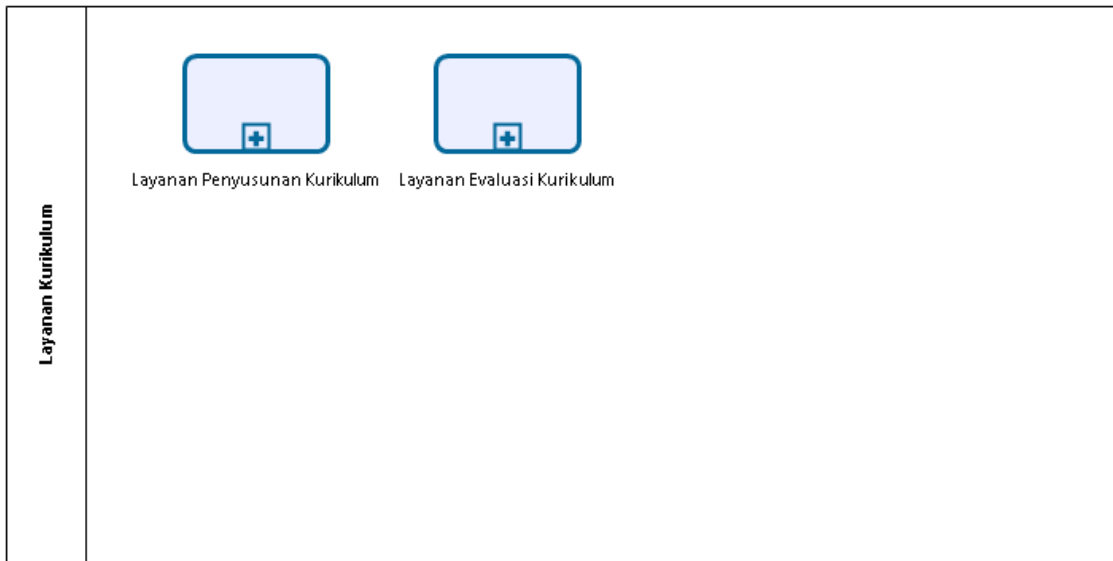

Level 4 Layanan Penyusunan Kurikulum

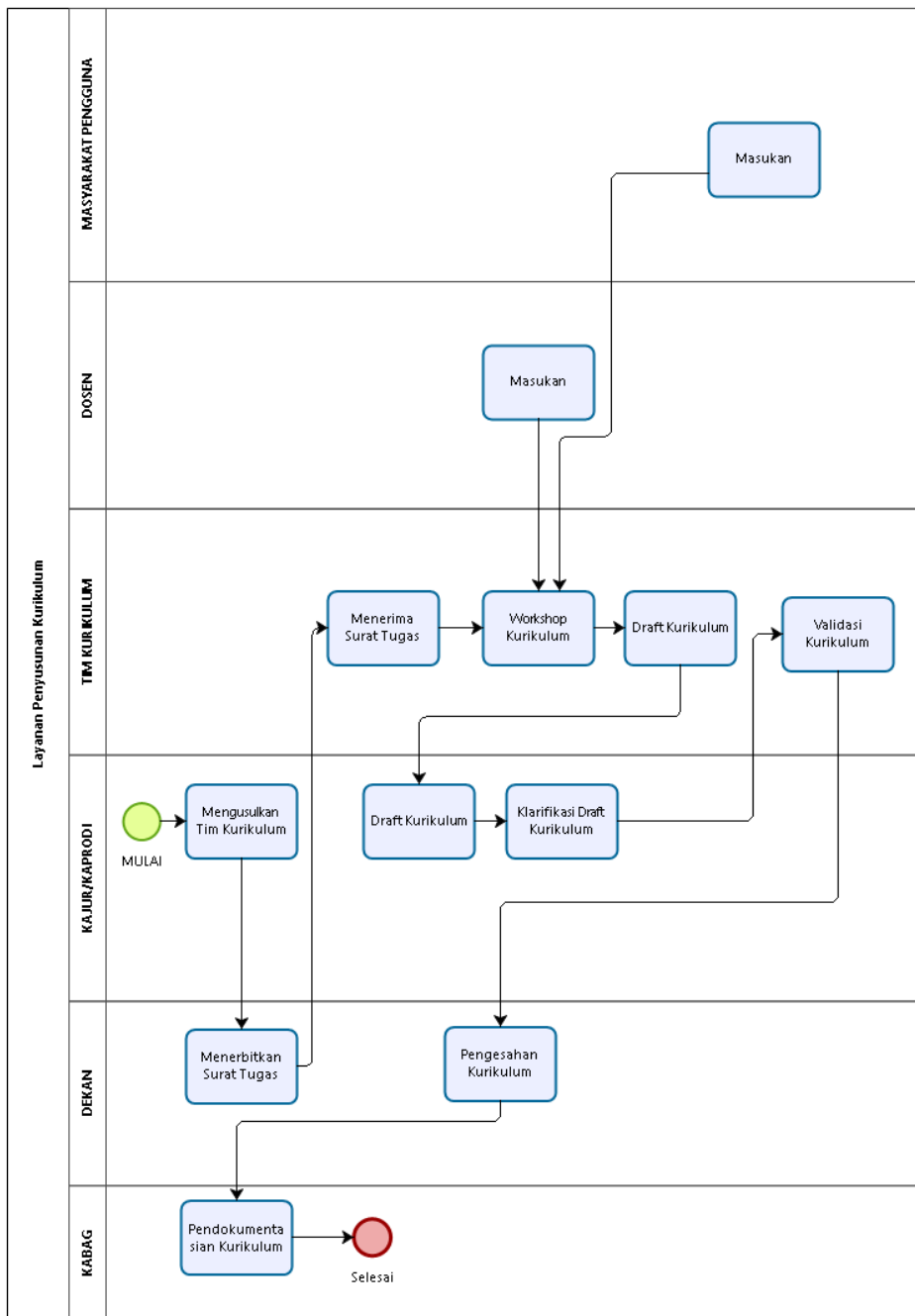

Level 4 Layanan Evaluasi Kurikulum

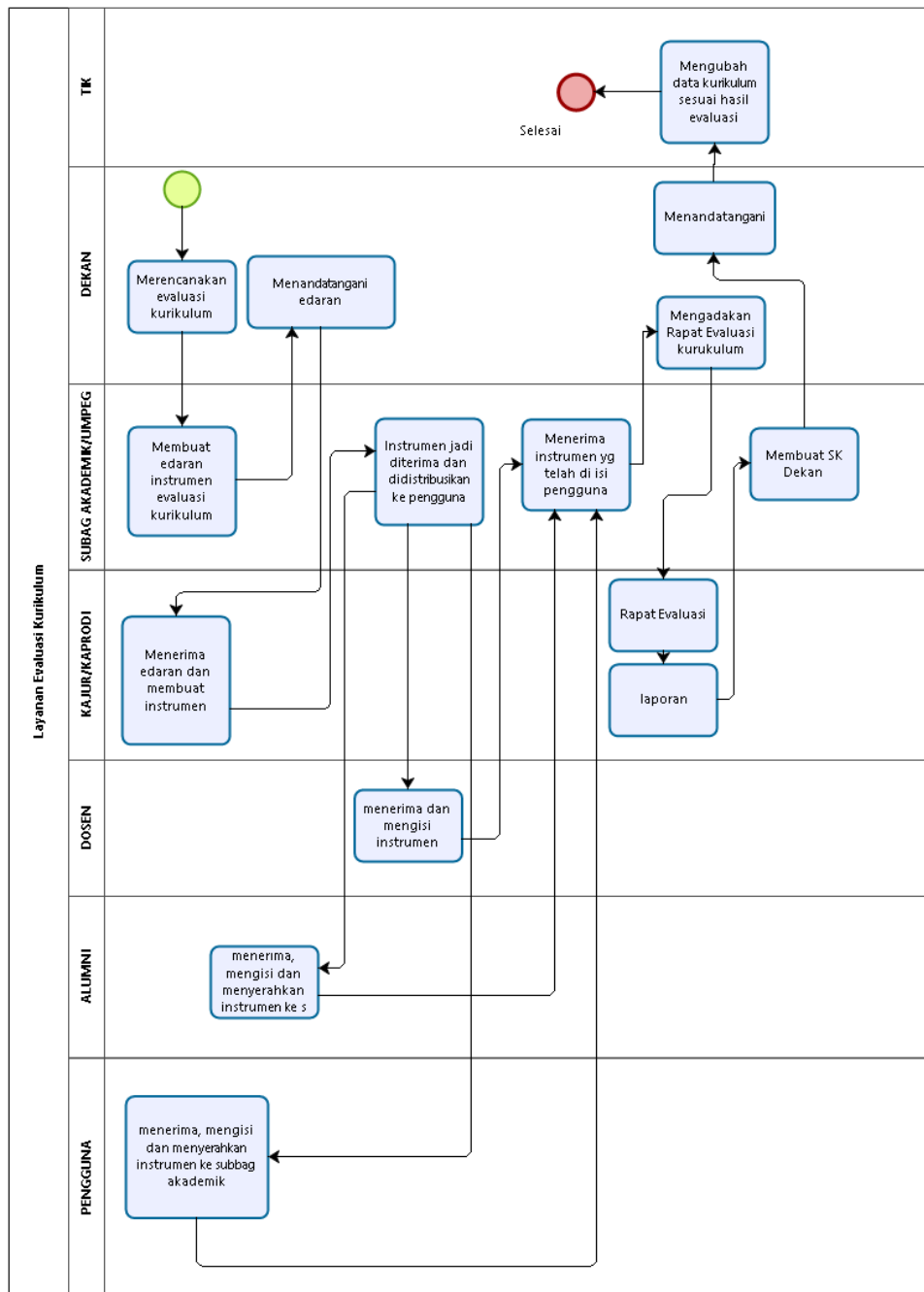

Level 3 Layanan Pembuatan Perangkat Pembelajaran

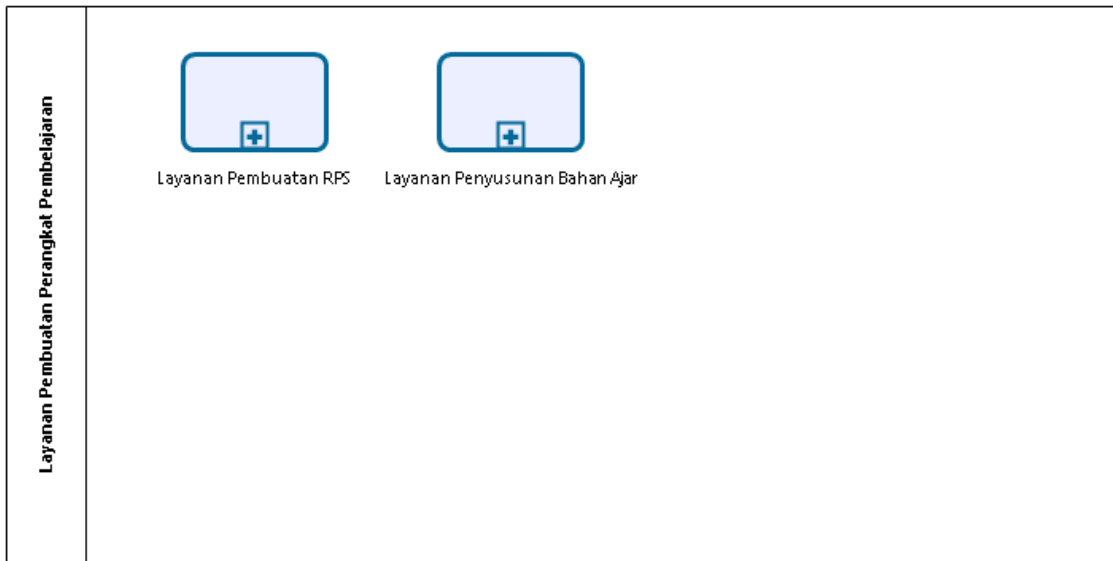

Level 4 Layanan Pembuatan RPS

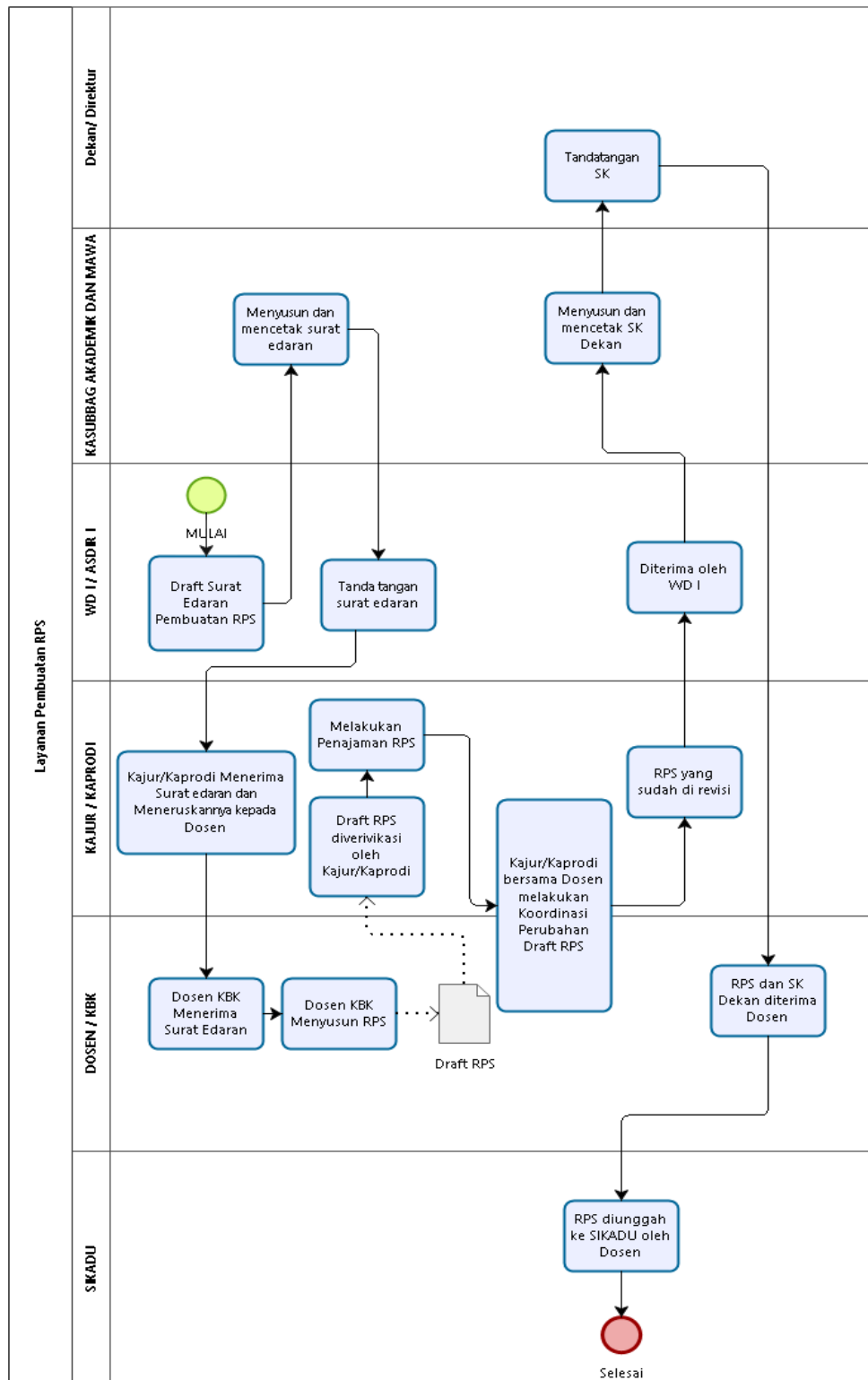

Level 4 Layanan Penyusunan Bahan Ajar

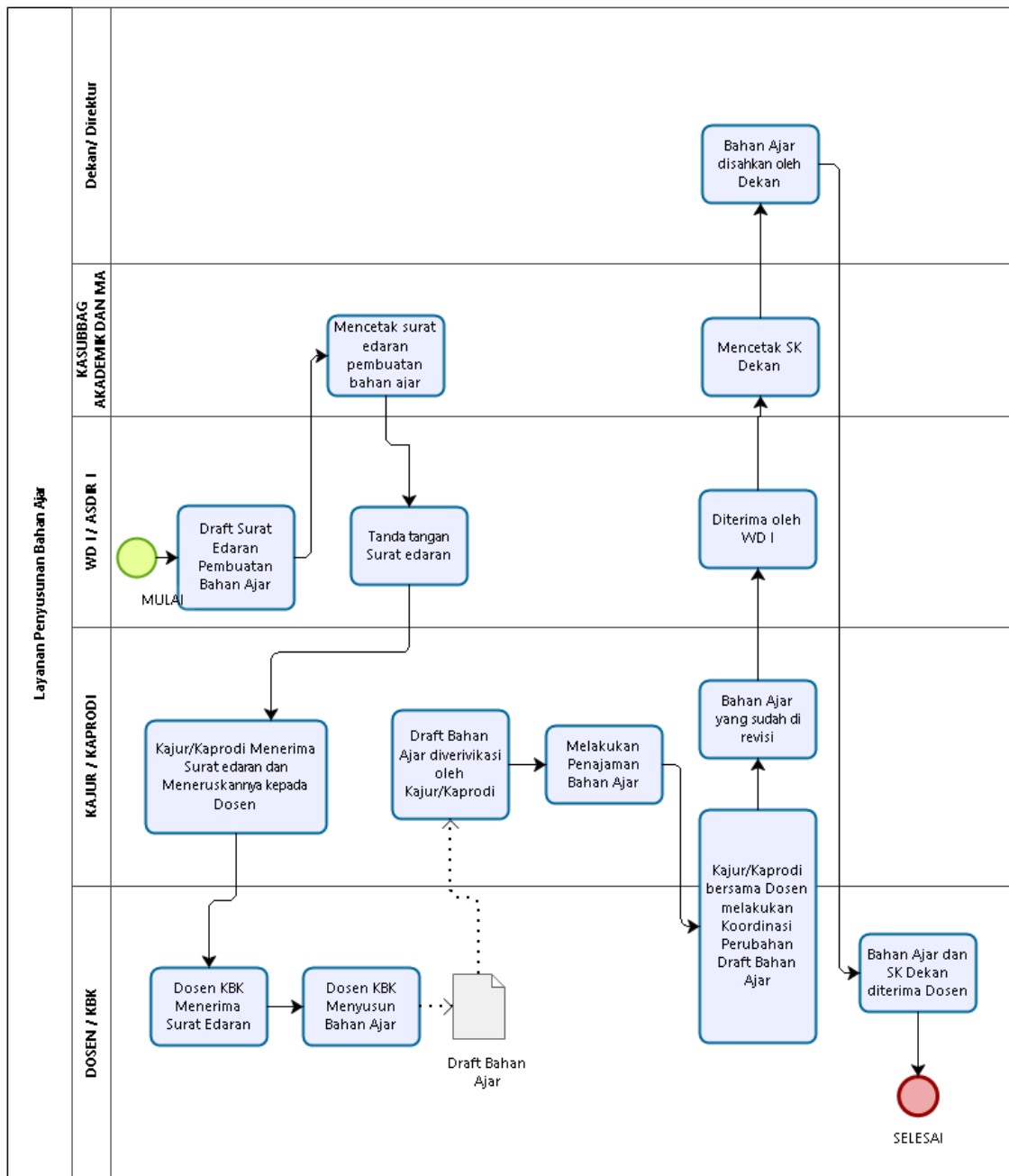

Level 3 Layanan Perkuliahan MKU MKDK

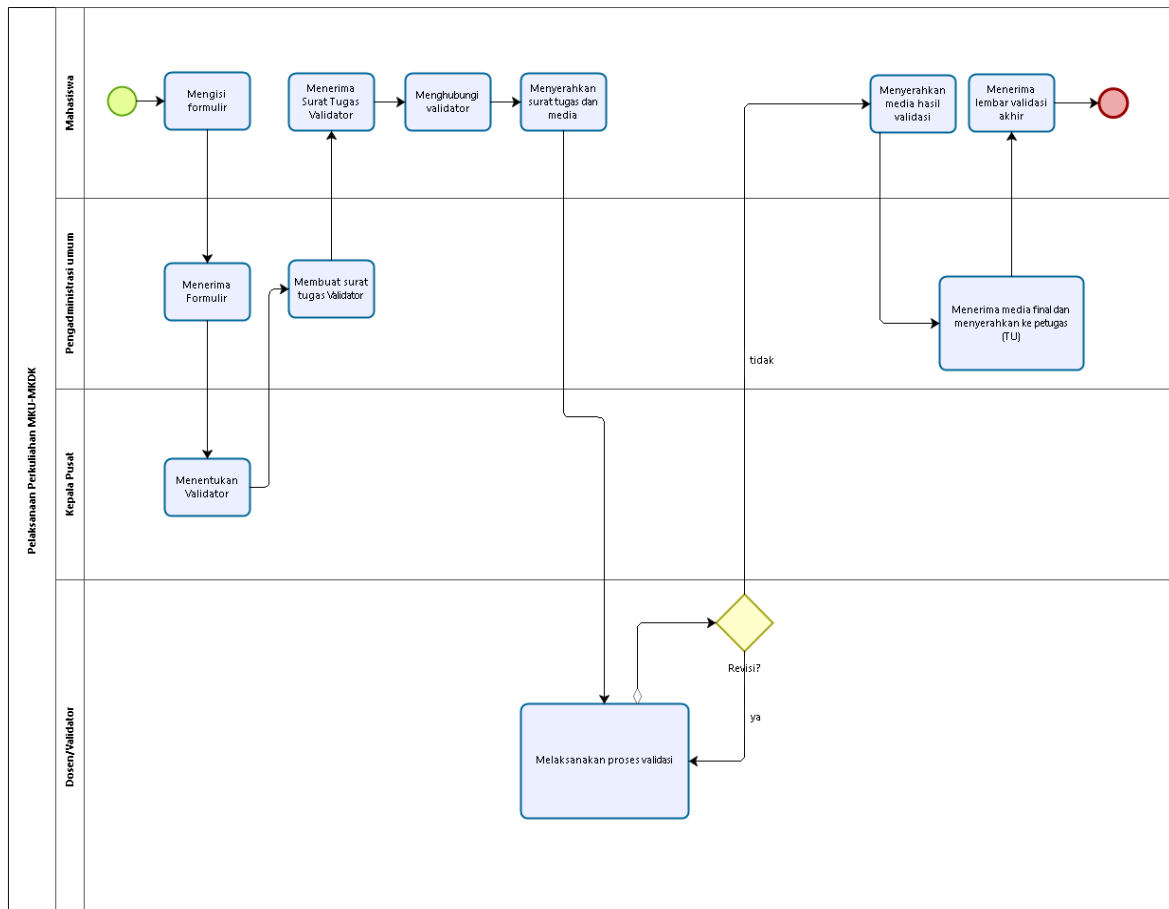

Level 2 Layanan Praktik Mahasiswa

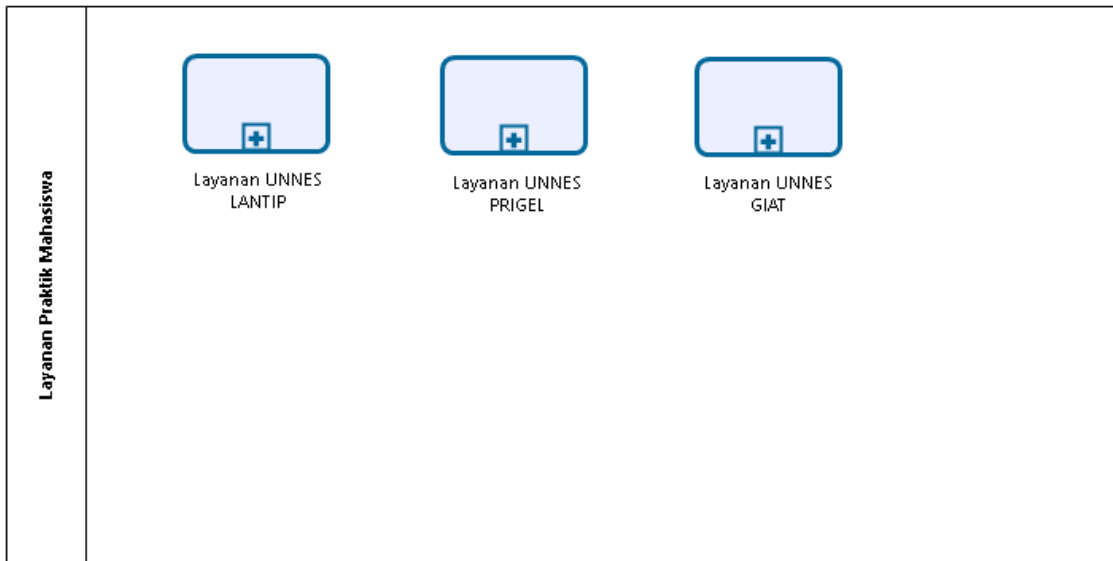

Level 3 Layanan UNNES LANTIP

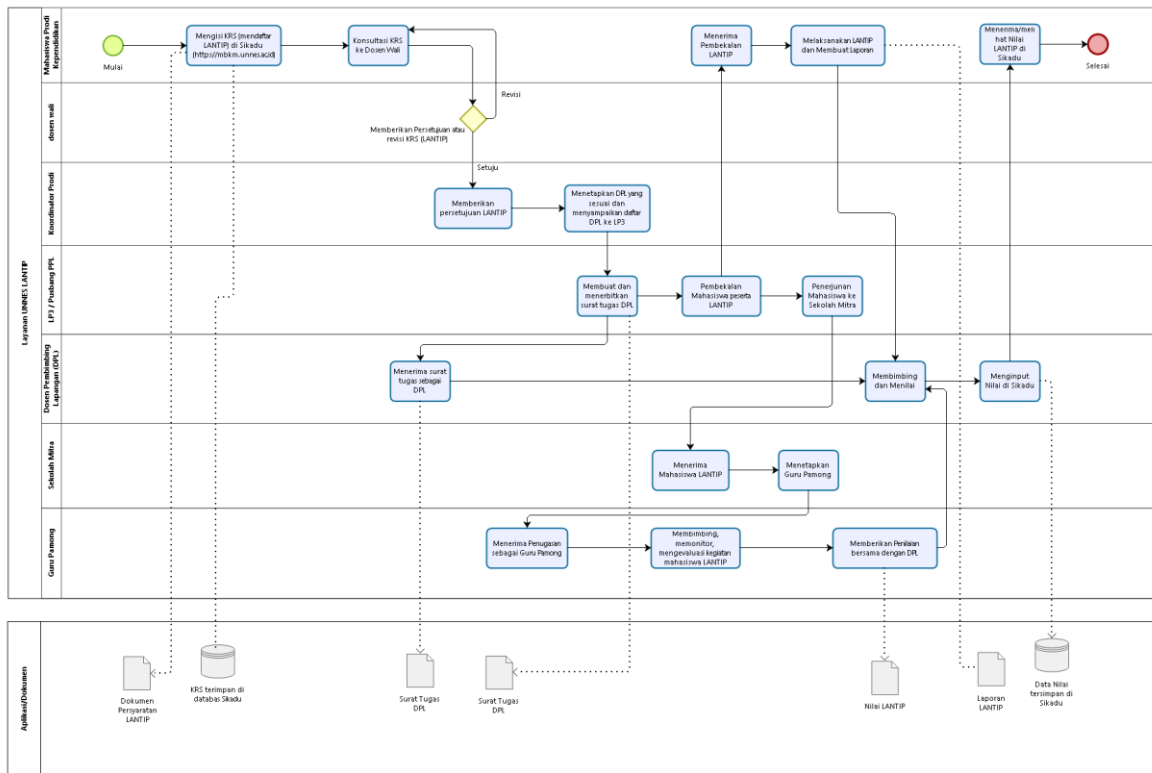

Level 3 Layanan UNNES PRIGEL

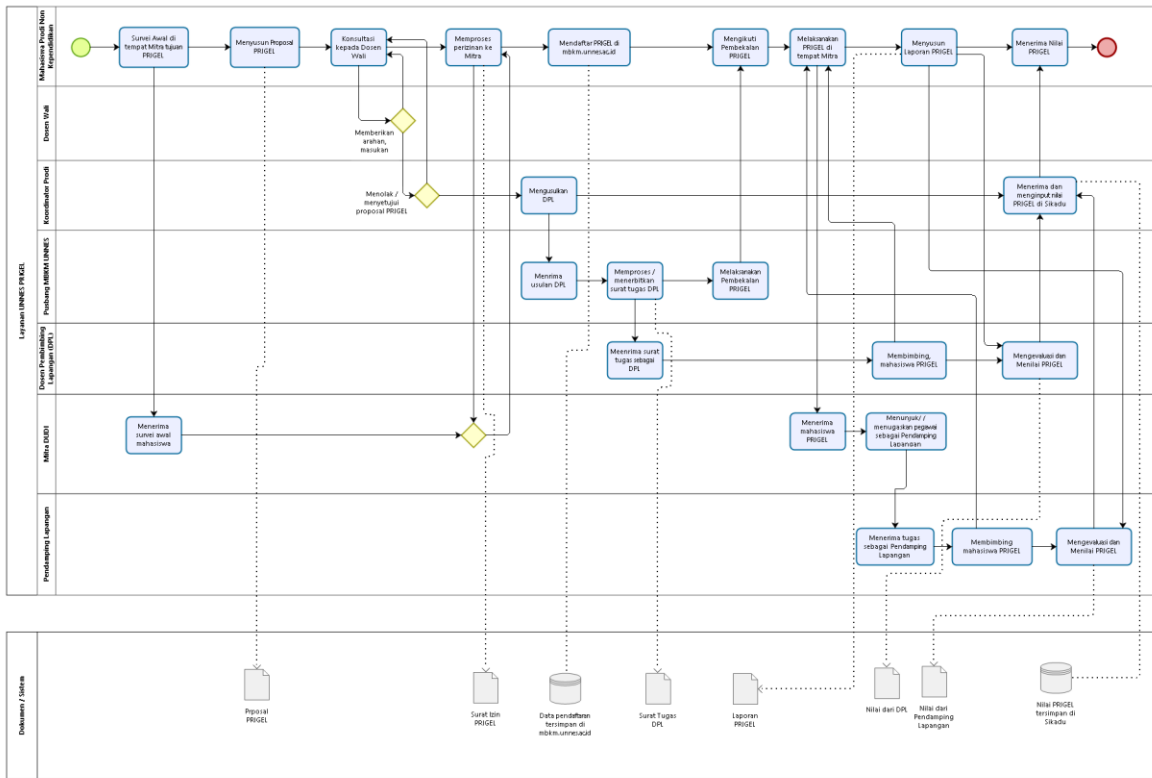

Level 3 Layanan UNNES GIAT

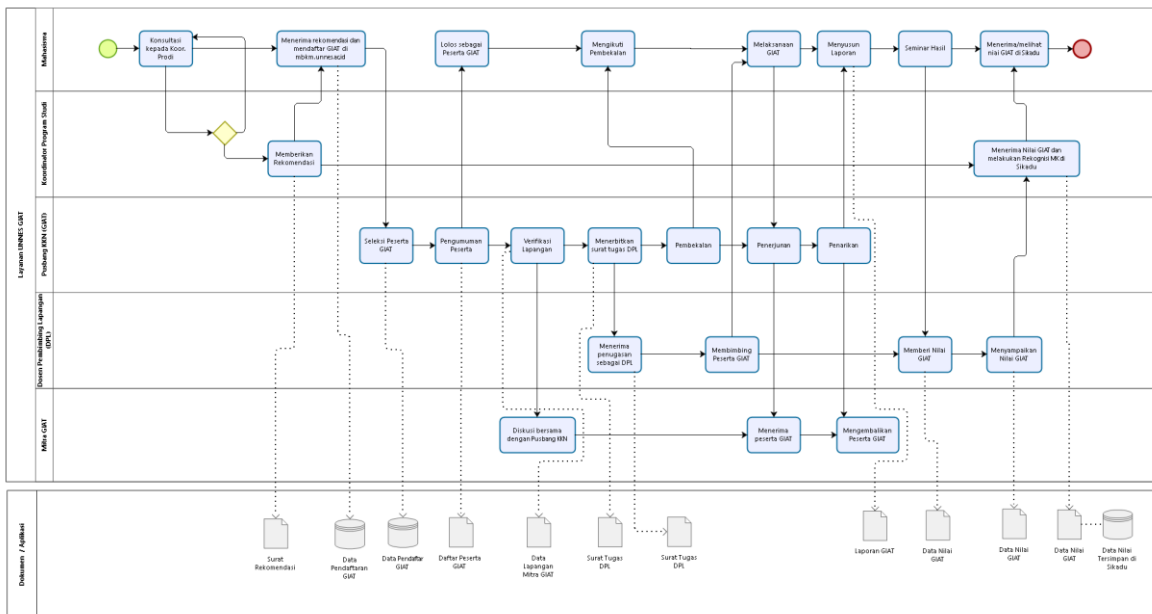

Level 1 Layanan Penelitian

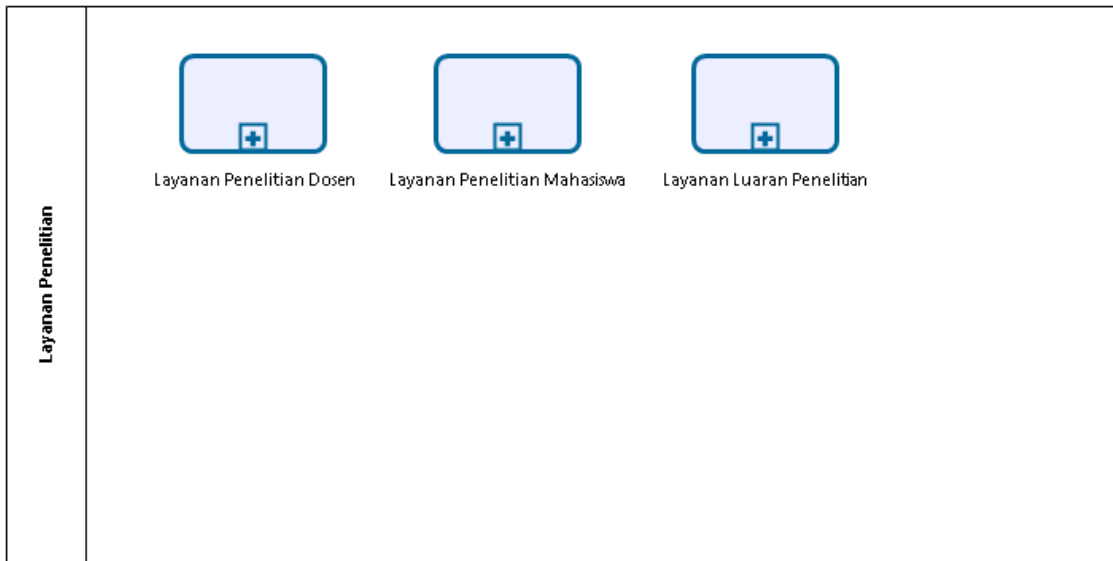

Powered by
bizagi
Modeler

Level 2 Layanan Penelitian Dosen

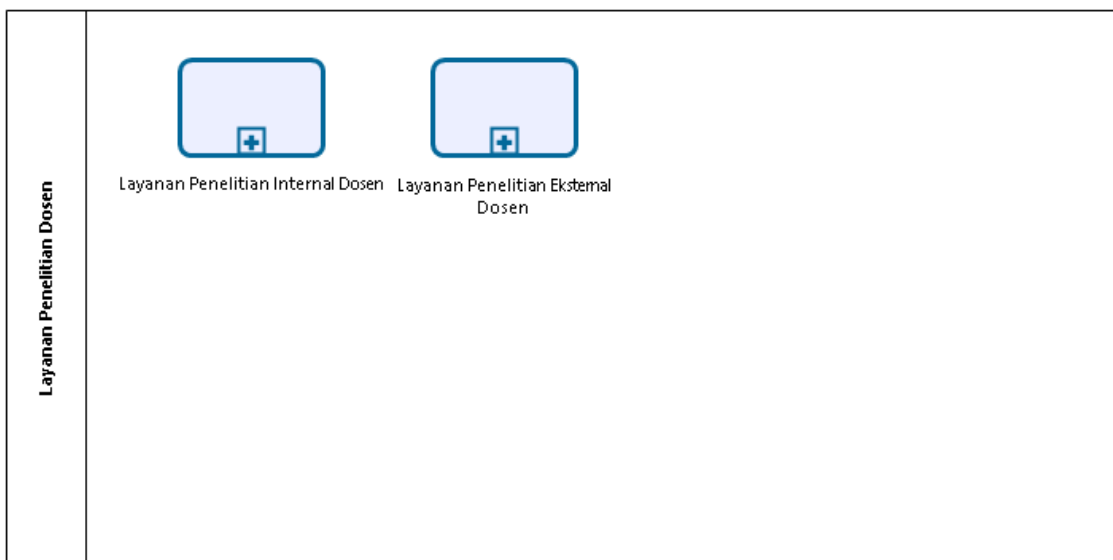

Powered by
bizagi
Modeler

Level 3 Layanan Penelitian Internal Dosen

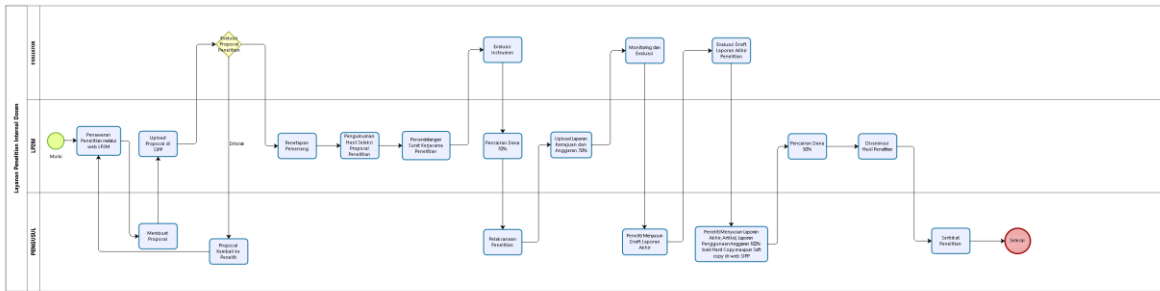

Level 3 Layanan Penelitian Eksternal Dosen

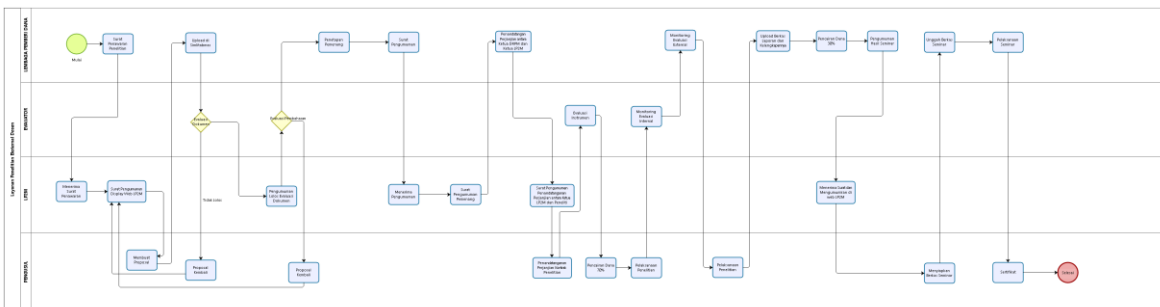

Level 2 Layanan Penelitian Mahasiswa

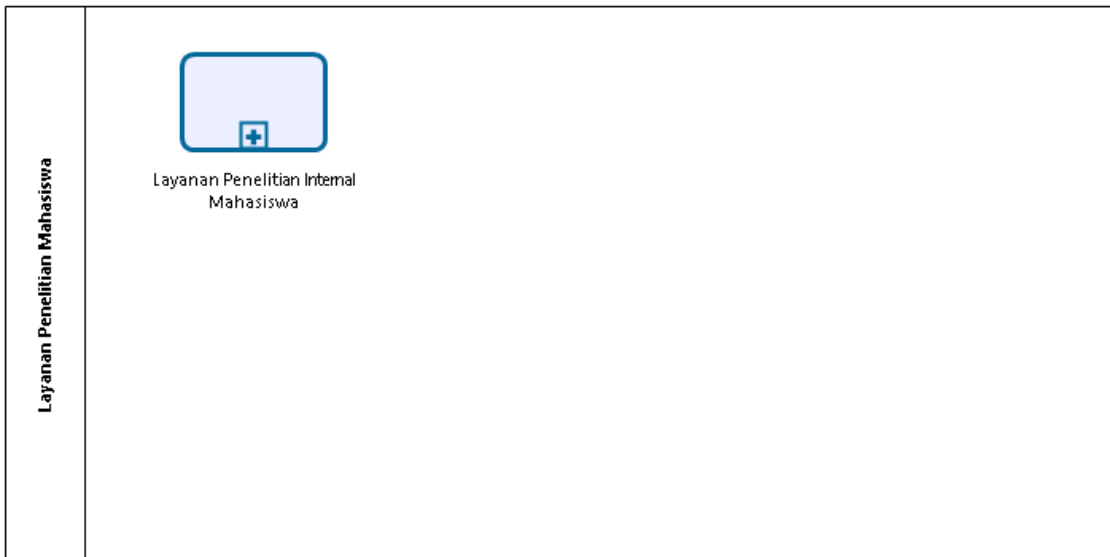

Level 3 Layanan Penelitian Internal Mahasiswa

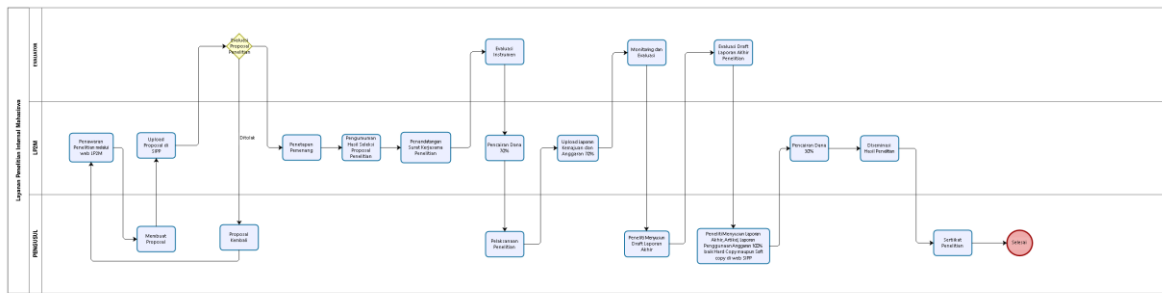

bizagi

Level 2 Layanan Luaran Penelitian

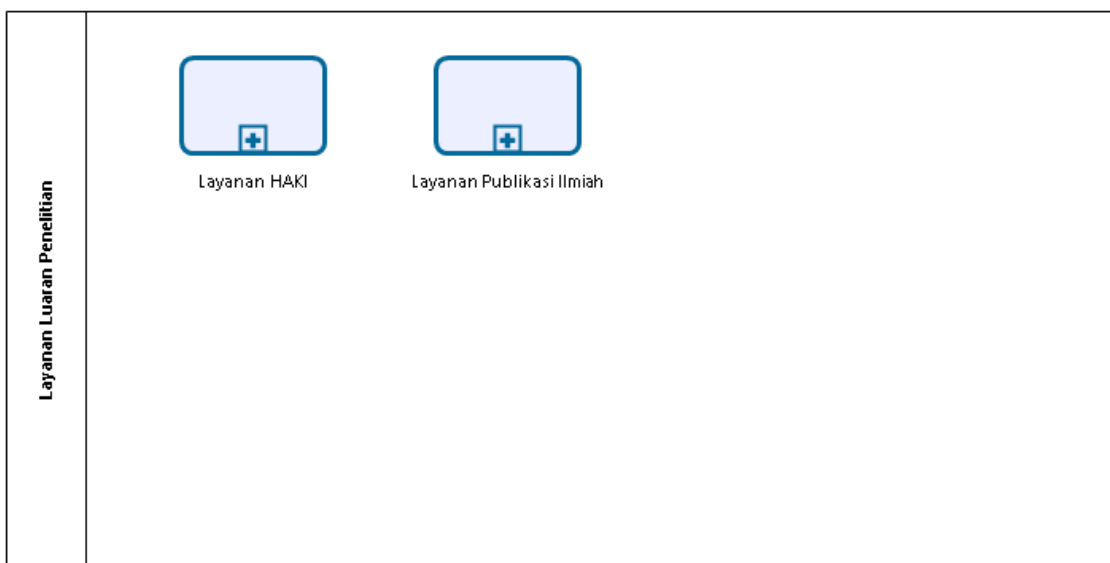

Powered by
bizagi
Modeler

Level 3 Layanan HAKI

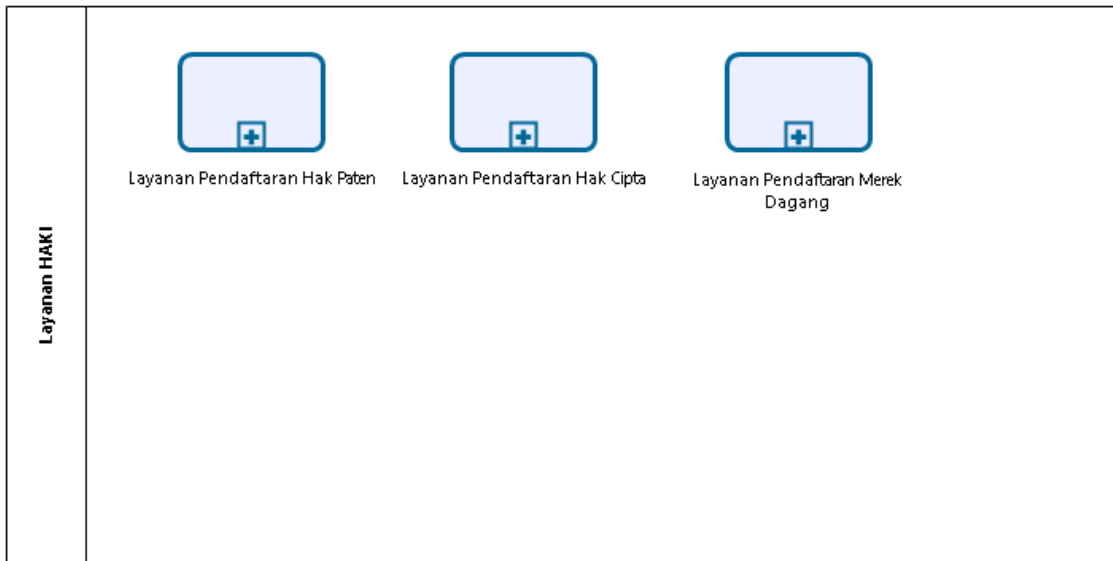

Powered by
bizagi
Modeler

Level 4 Layanan Pendaftaran Hak Paten

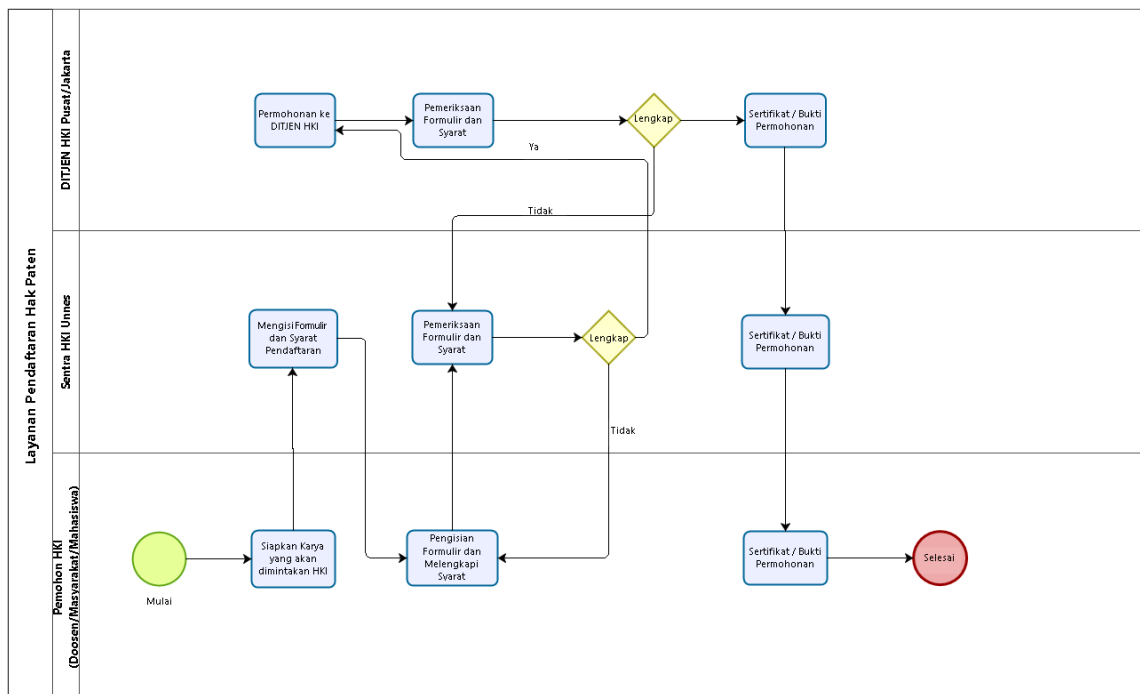

Powered by
bizagi
Modeler

Level 4 Layanan Pendaftaran Hak Cipta

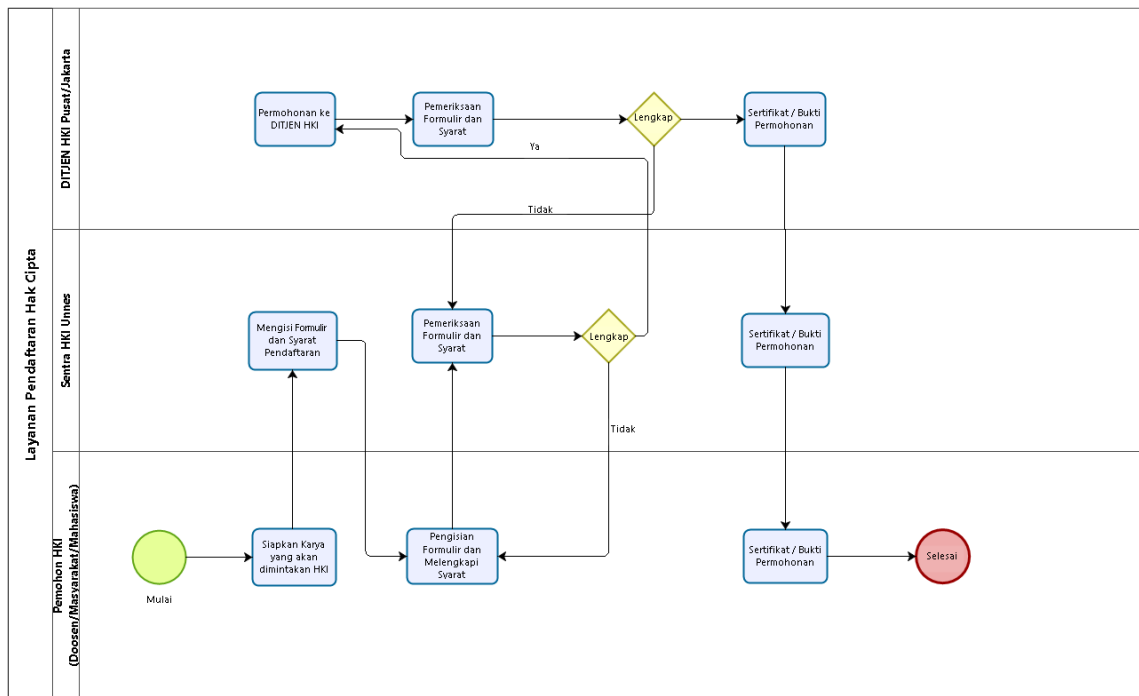

Level 4 Layanan Pendaftaran Merek Dagang

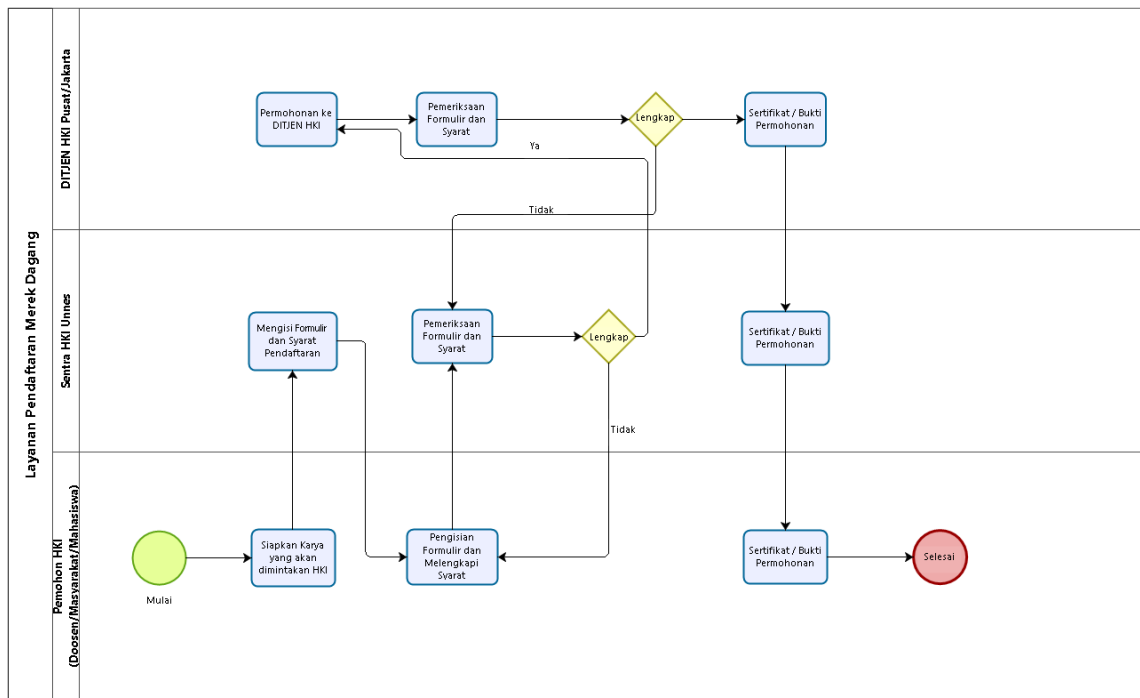

Powered by
bizagi
Master

Level 3 Layanan Publikasi Ilmiah

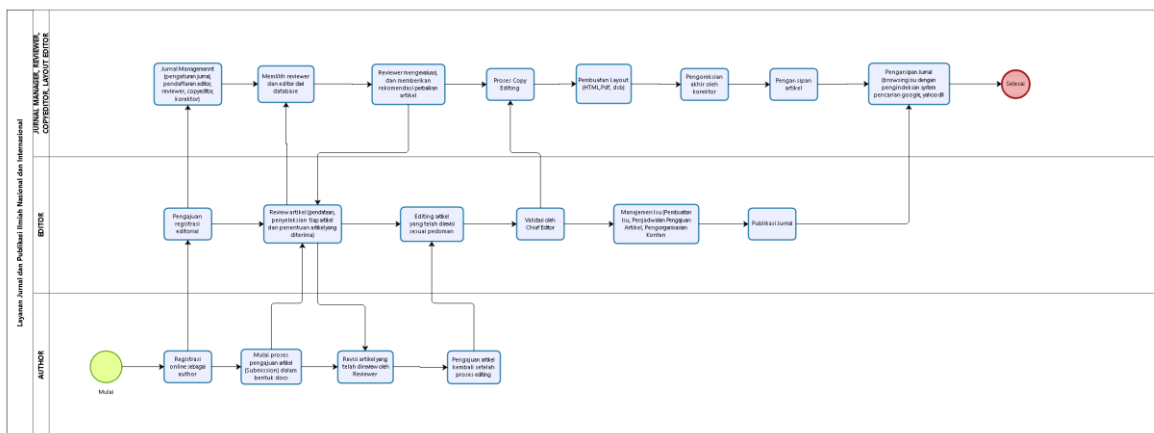

Powered by
bizagi
Master

Level 1 Layanan Pengabdian kepada Masyarakat

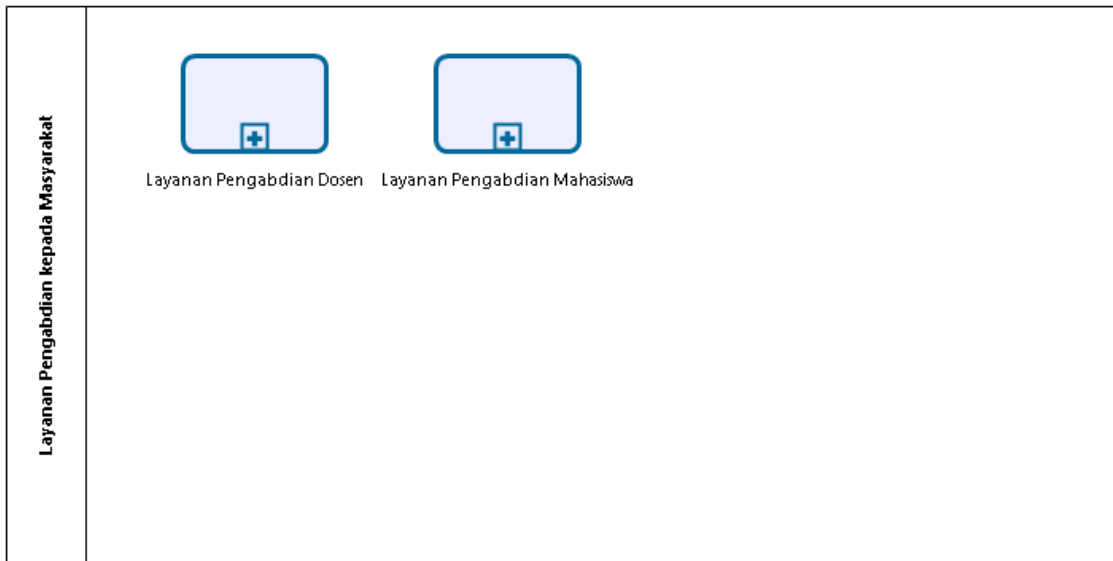

Powered by
bizagi
Modeler

Level 2 Layanan Pengabdian Dosen

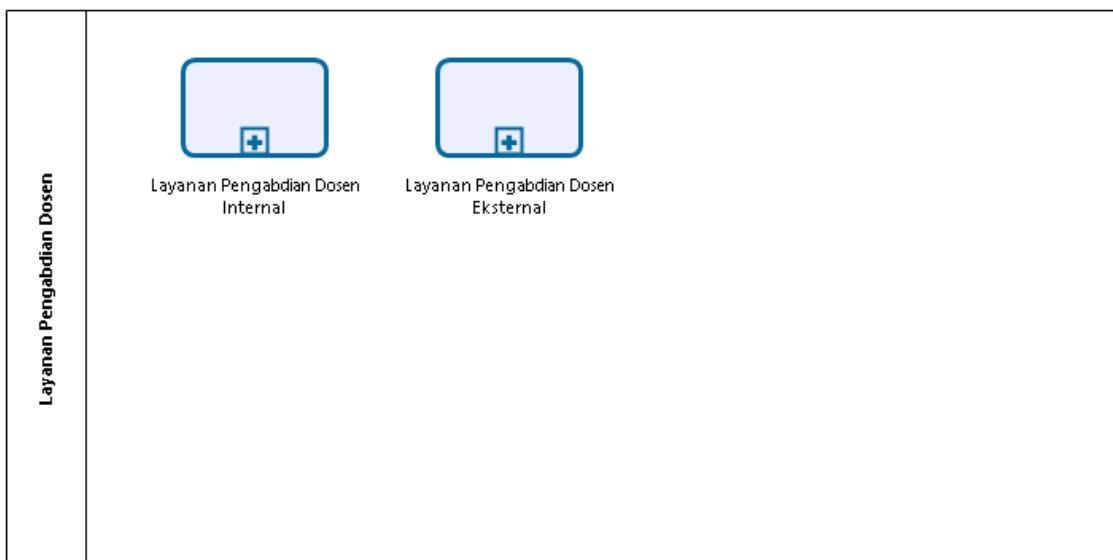

Powered by
bizagi
Modeler

Level 3 Layanan UNNES GIAT

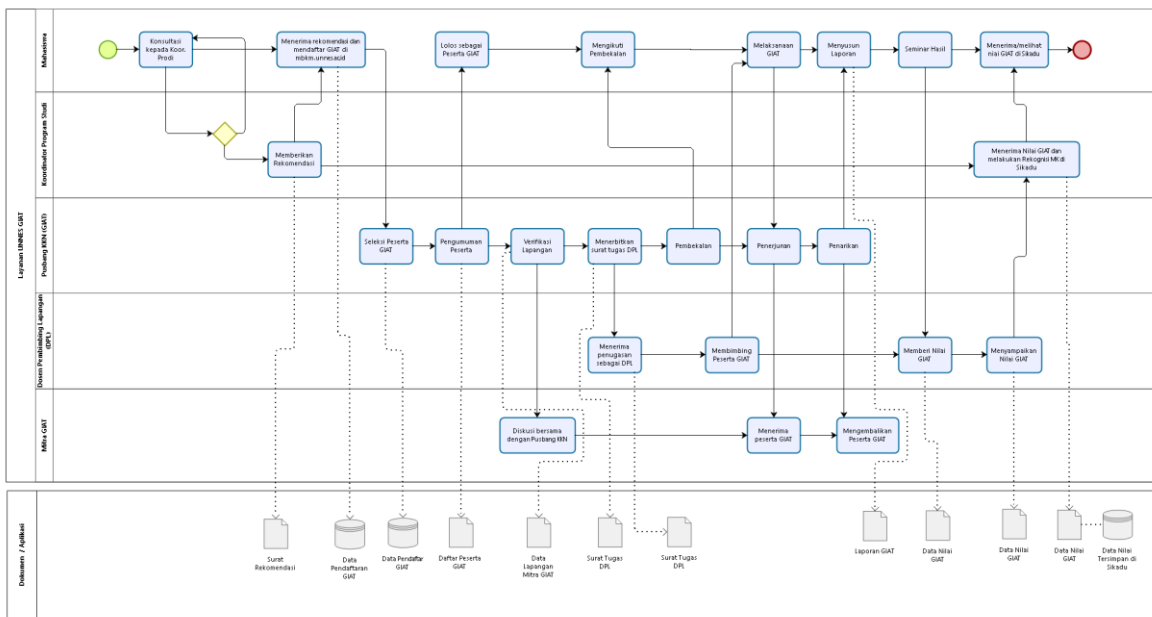

Level 1 Layanan Akademik, Kemahasiswaan dan Kerjasama

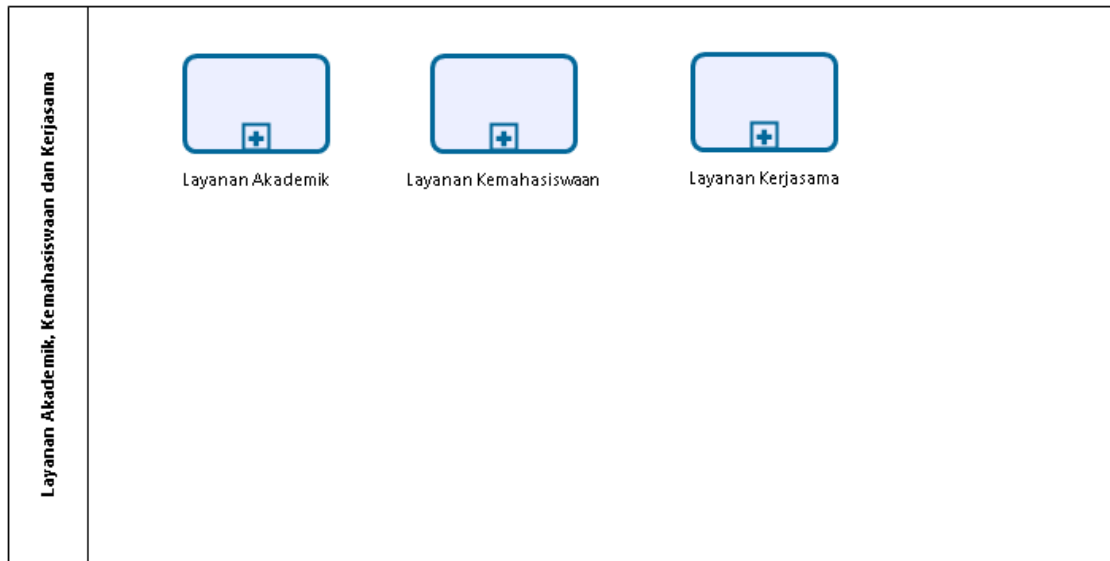

Powered by
bizagi
Modeler

Level 2 Layanan Akademik

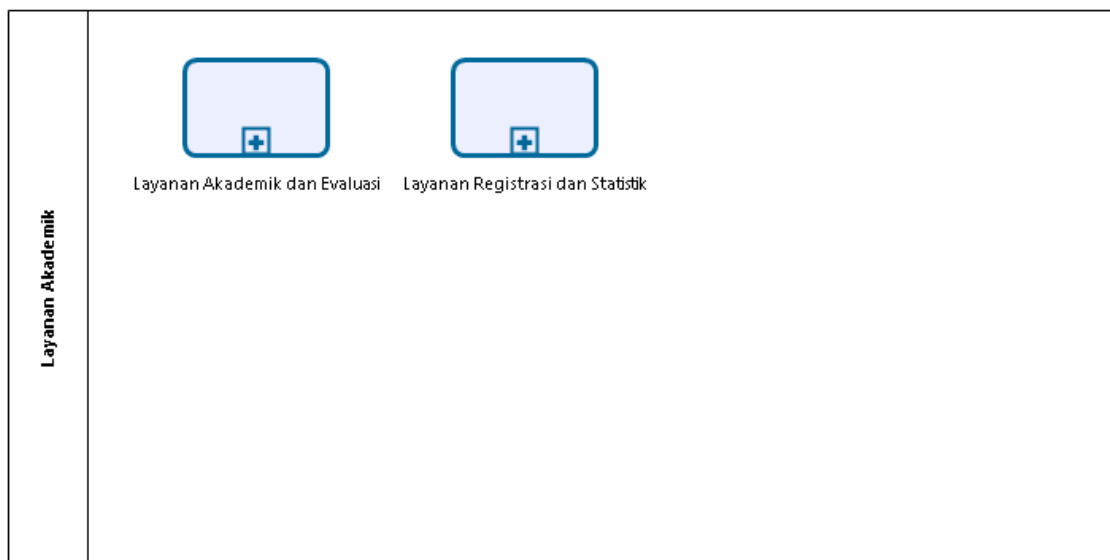

Powered by
bizagi
Modeler

Level 3 Layanan Akademik dan Evaluasi

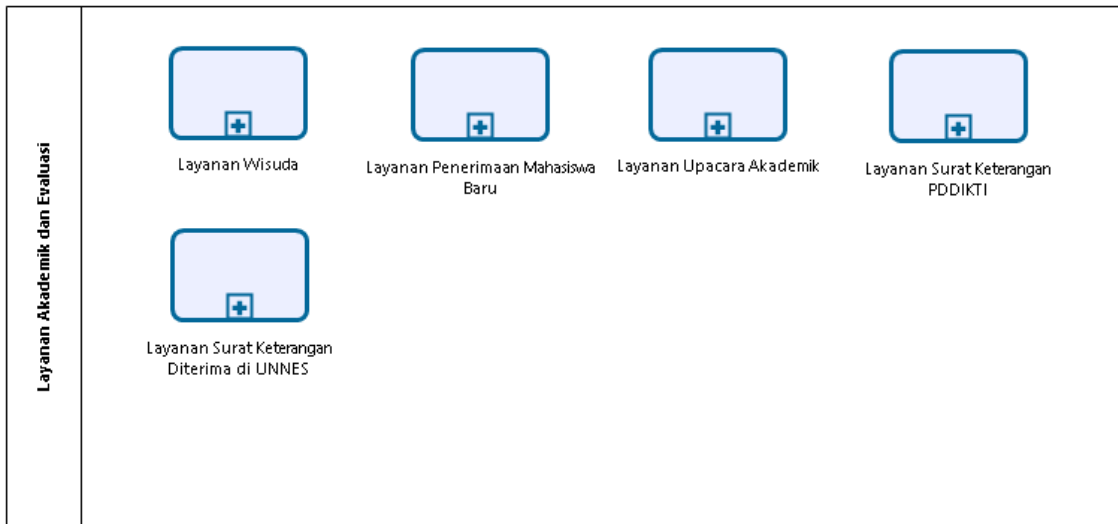

Powered by
bizagi
Modeler

Level 4 Layanan Wisuda

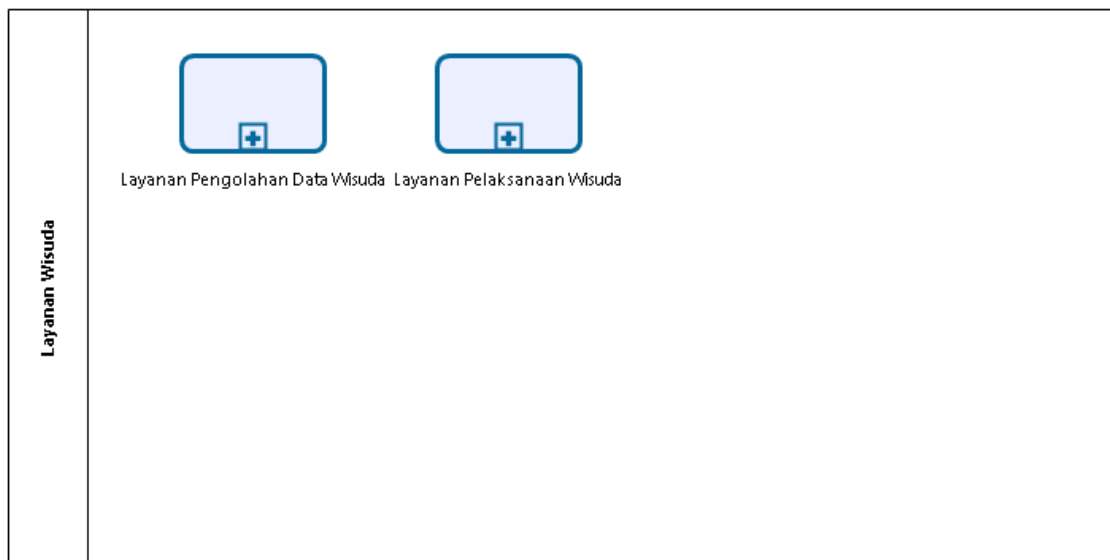

Powered by
bizagi
Modeler

Level 5 Layanan Pengolahan Data Wisuda

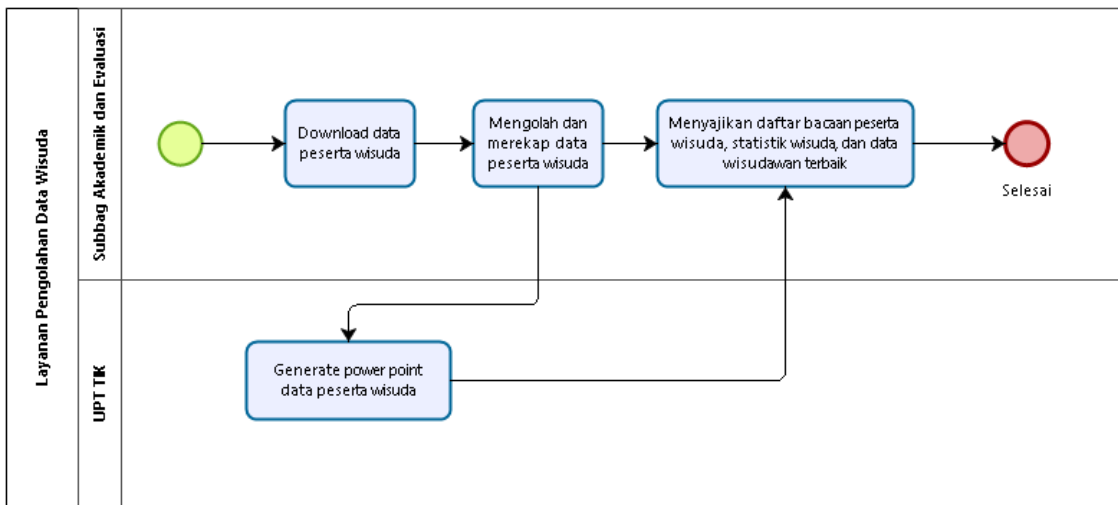

Powered by
bizagi
Modeler

Level 5 Layanan Pelaksanaan Wisuda

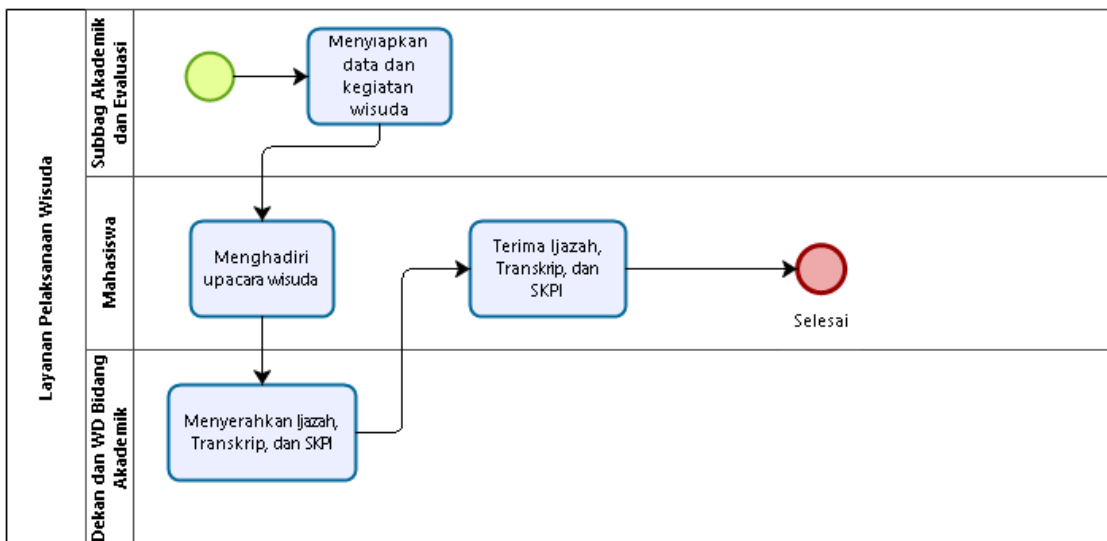

Powered by
bizagi
Modeler

Level 4 Layanan Penerimaan Mahasiswa Baru

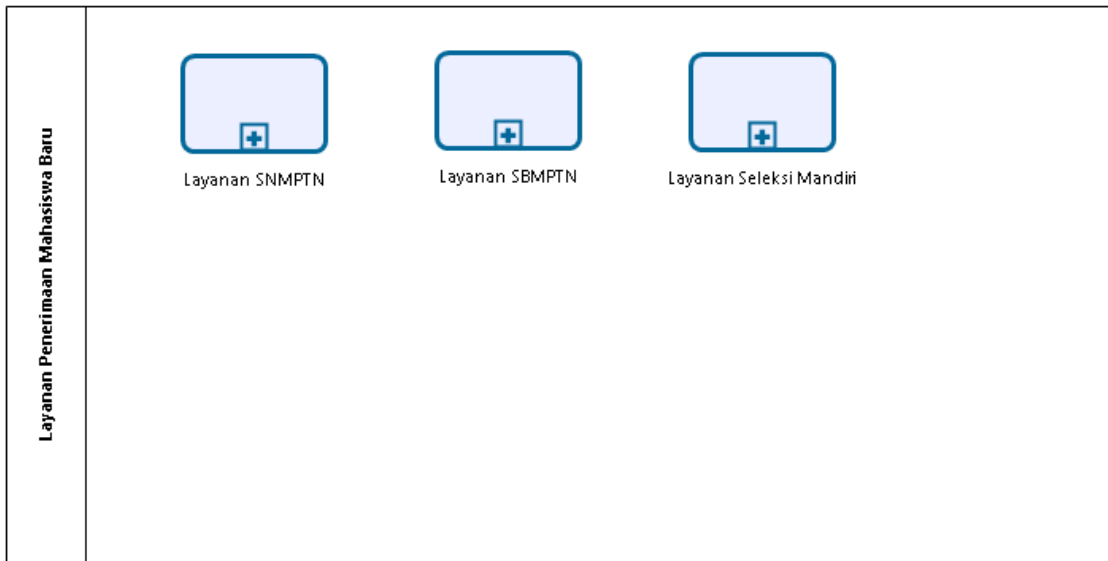

Powered by
bizagi
Modeler

Level 5 Layanan SNMPTN

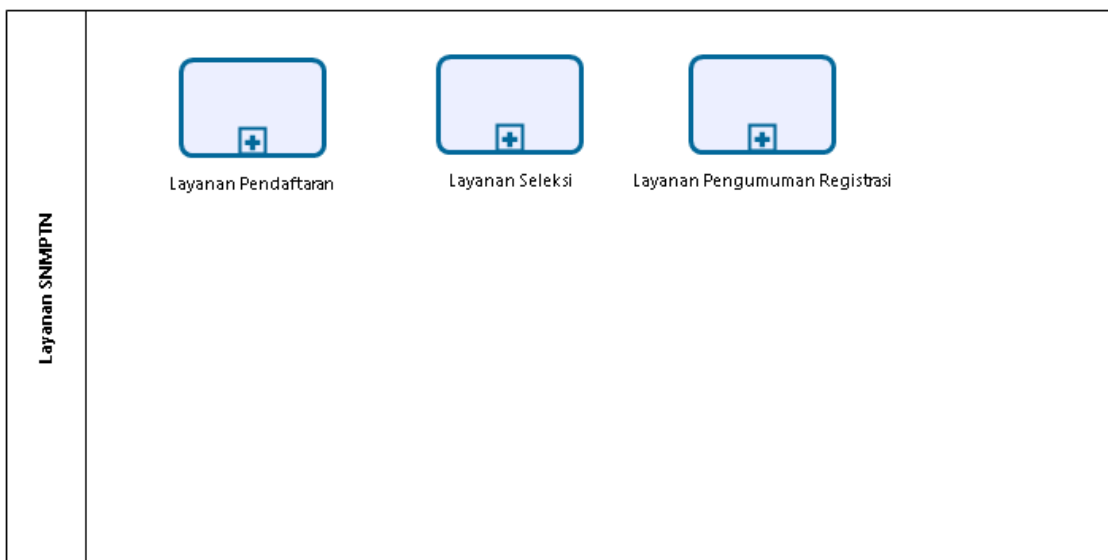

Powered by
bizagi
Modeler

Level 6 Layanan Pendaftaran SNMPTN

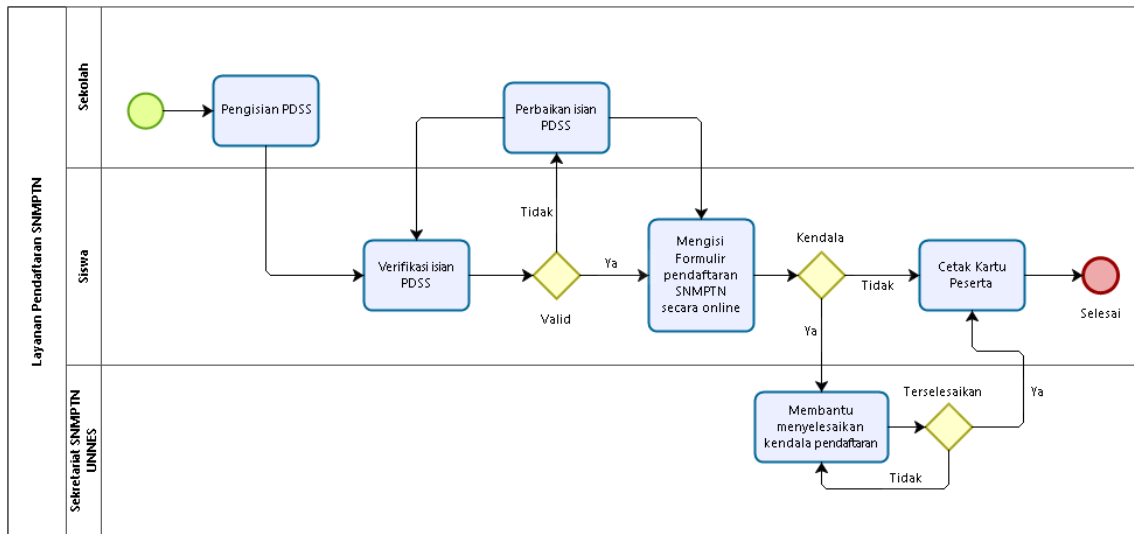

Level 6 Layanan Seleksi SNMPTN

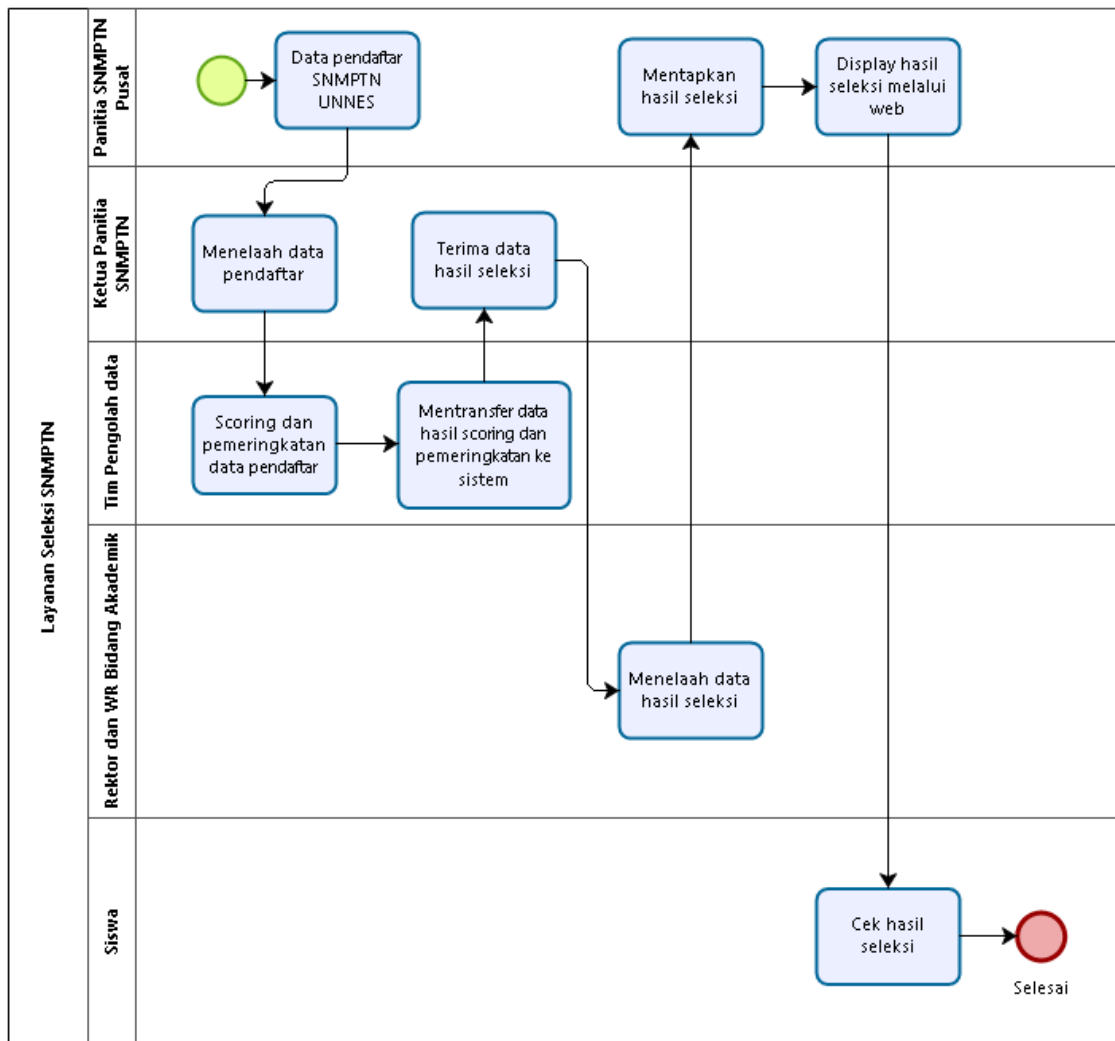

Level 6 Layanan Pengumuman Registrasi SNMPTN

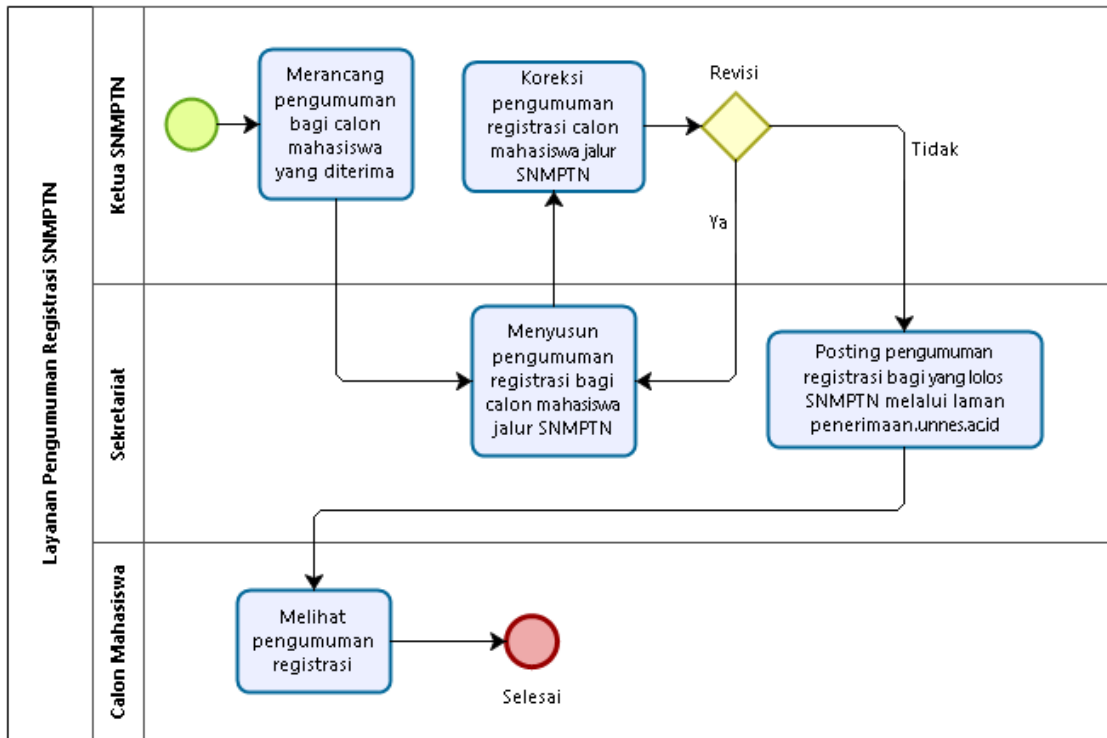

Level 5 Layanan SBMPTN

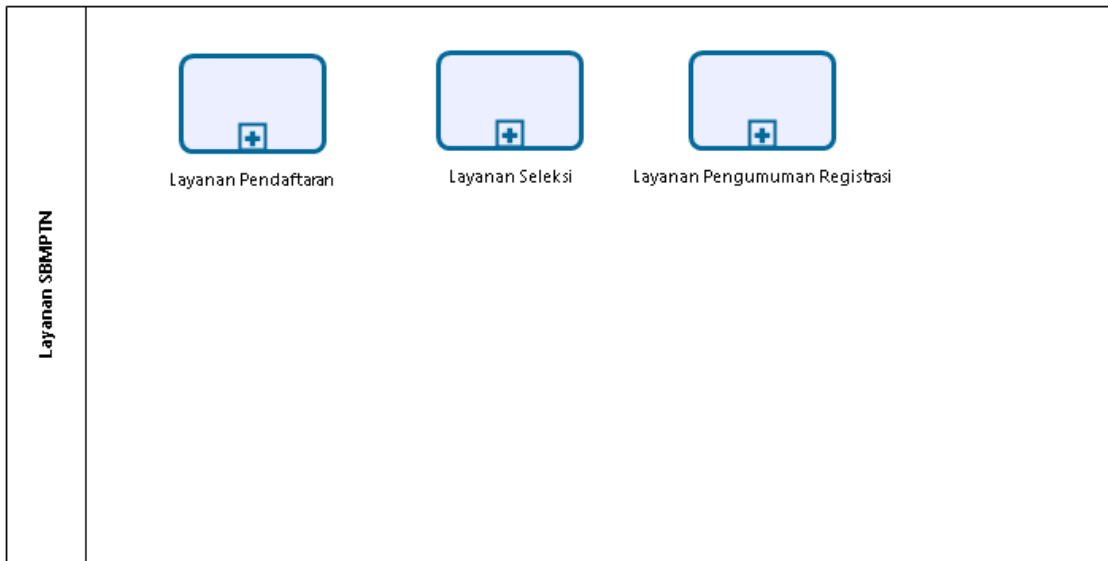

Powered by
bizagi
Modeler

Level 6 Layanan Pendaftaran SBMPTN

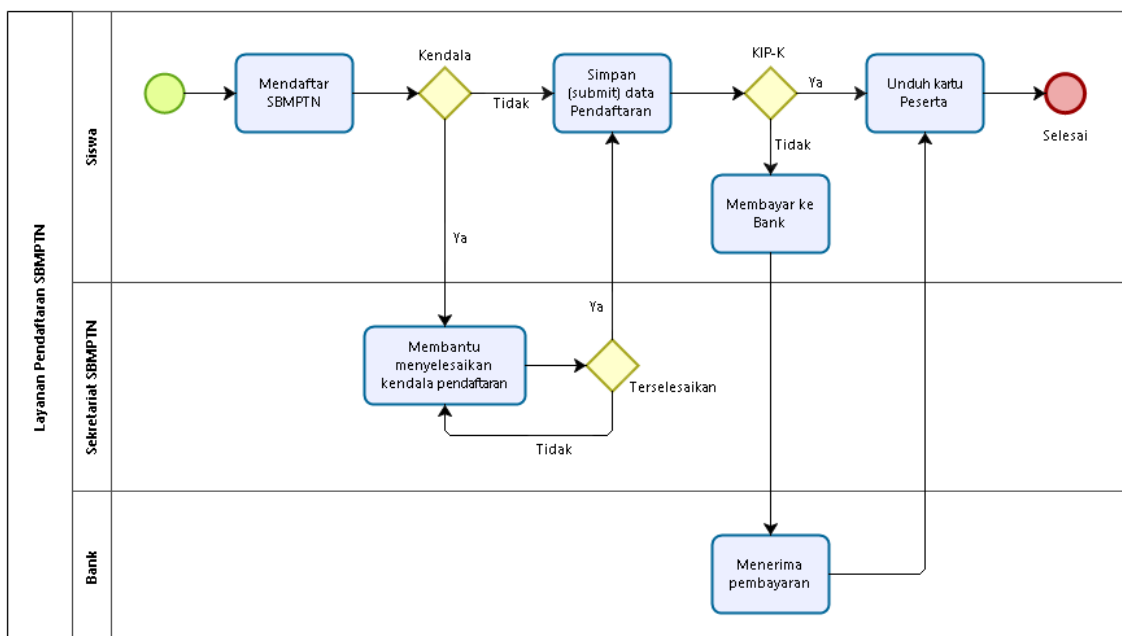

Powered by
bizagi
Modeler

Level 6 Layanan Seleksi SBMPTN

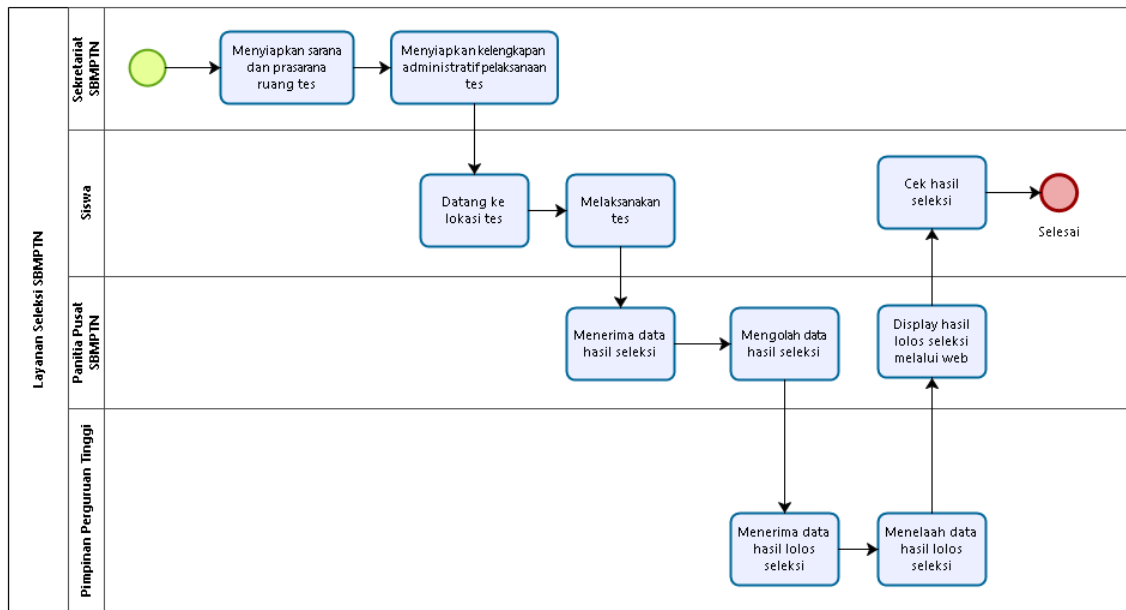

Powered by
bizagi
Modeler

Level 6 Layanan Pengumuman Registrasi SBMPTN

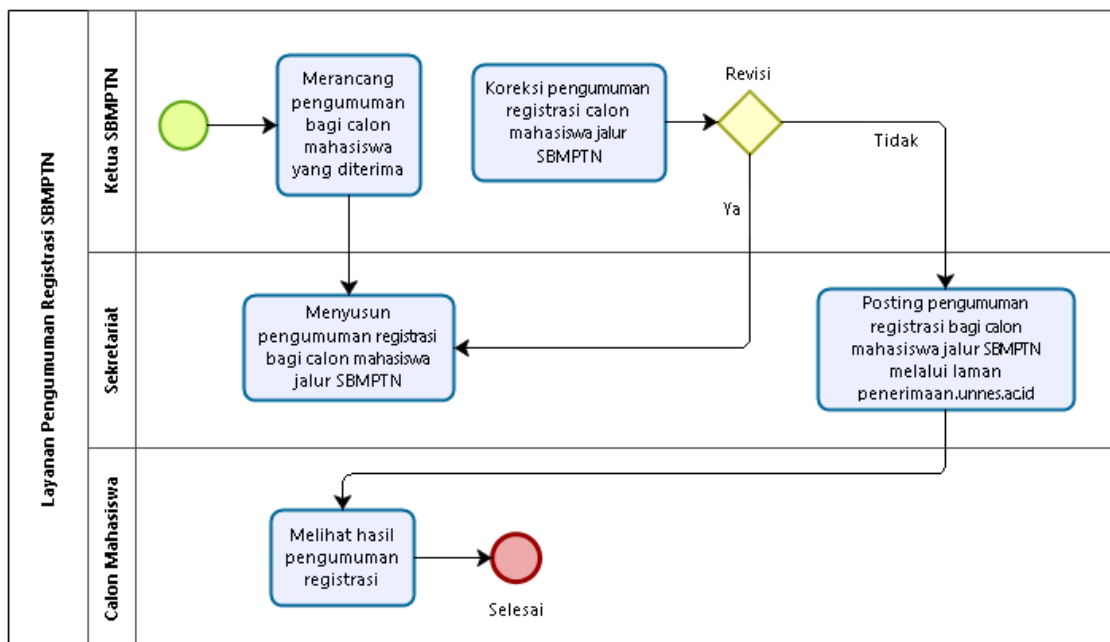

Powered by
bizagi
Modeler

Level 5 Layanan Seleksi Mandiri



Level 6 Layanan Pendaftaran Seleksi Mandiri

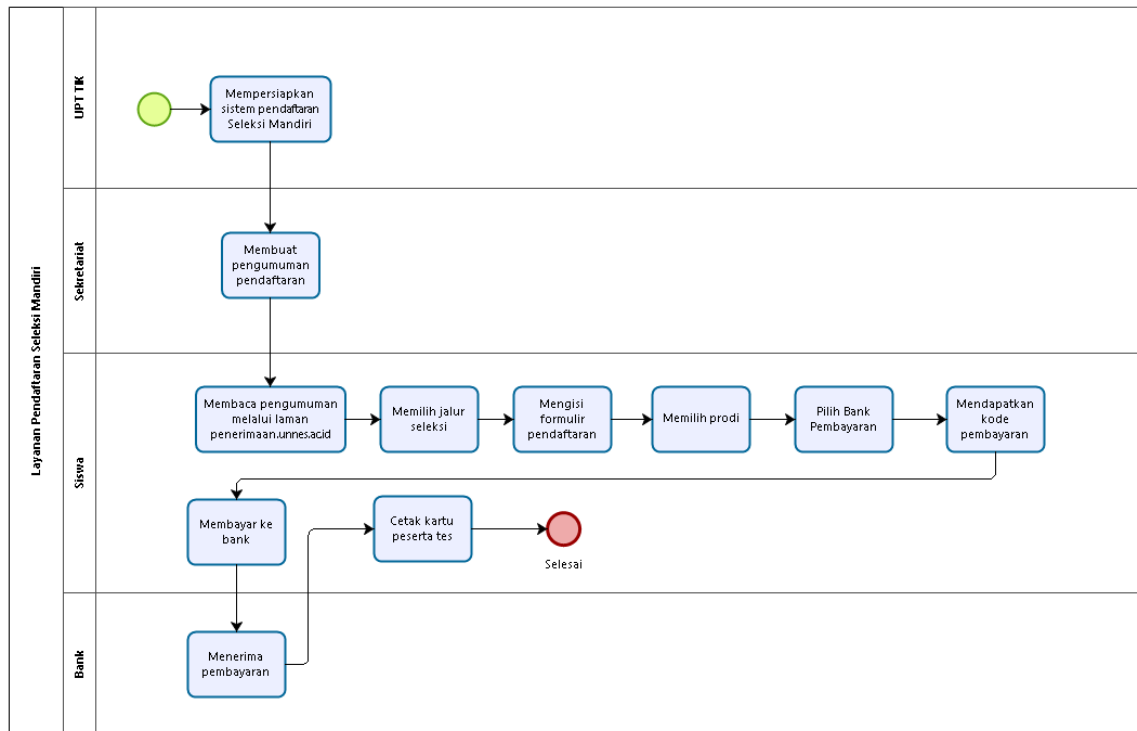

Level 6 Layanan Tes Seleksi Mandiri

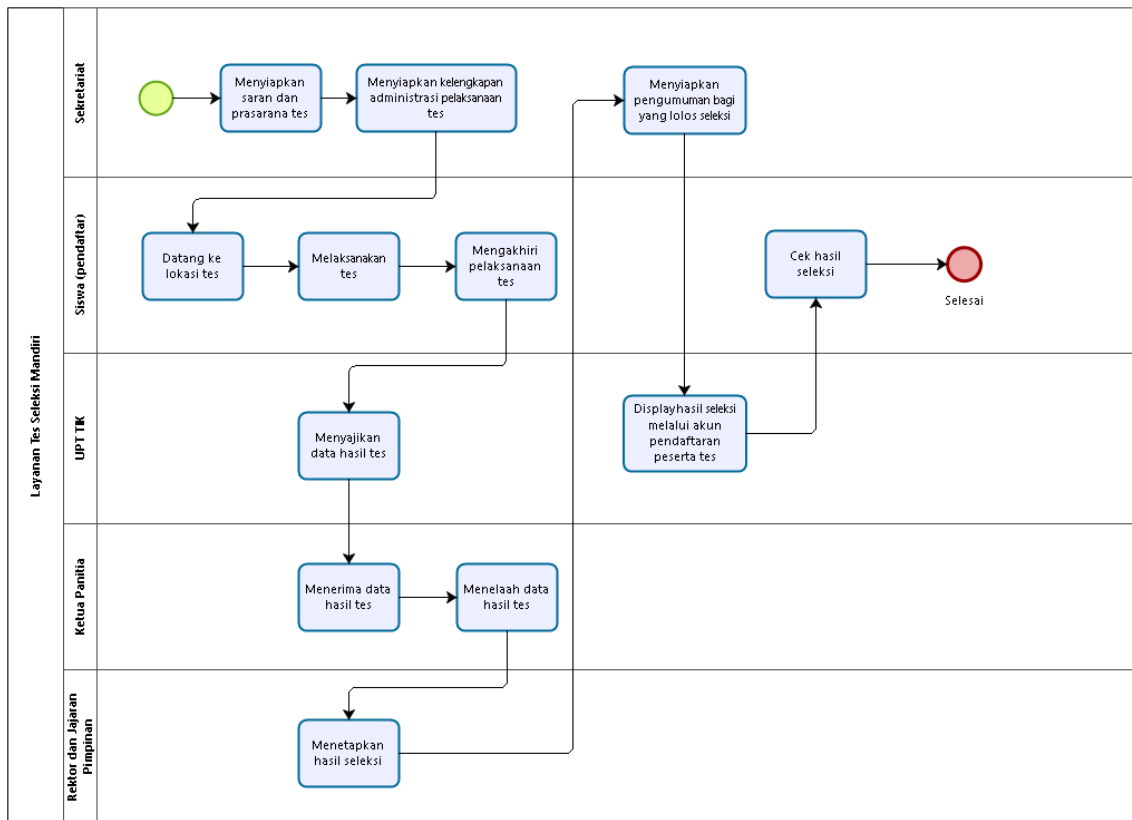

Level 6 Layanan Pengumuman Registrasi Seleksi Mandiri

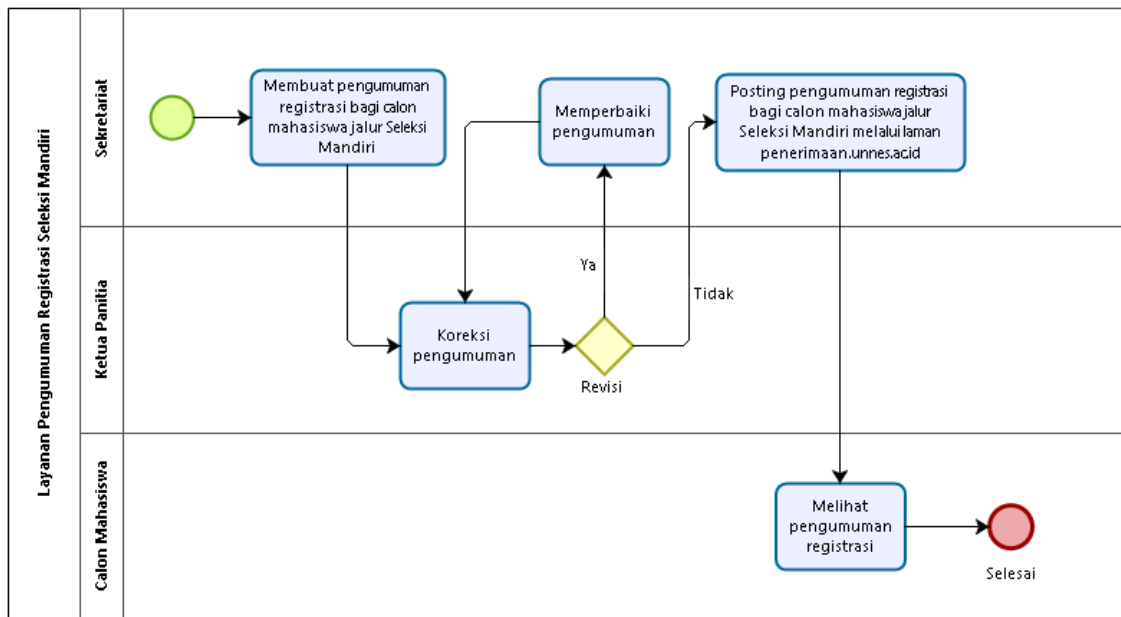

Level 4 Layanan Upacara Akademik

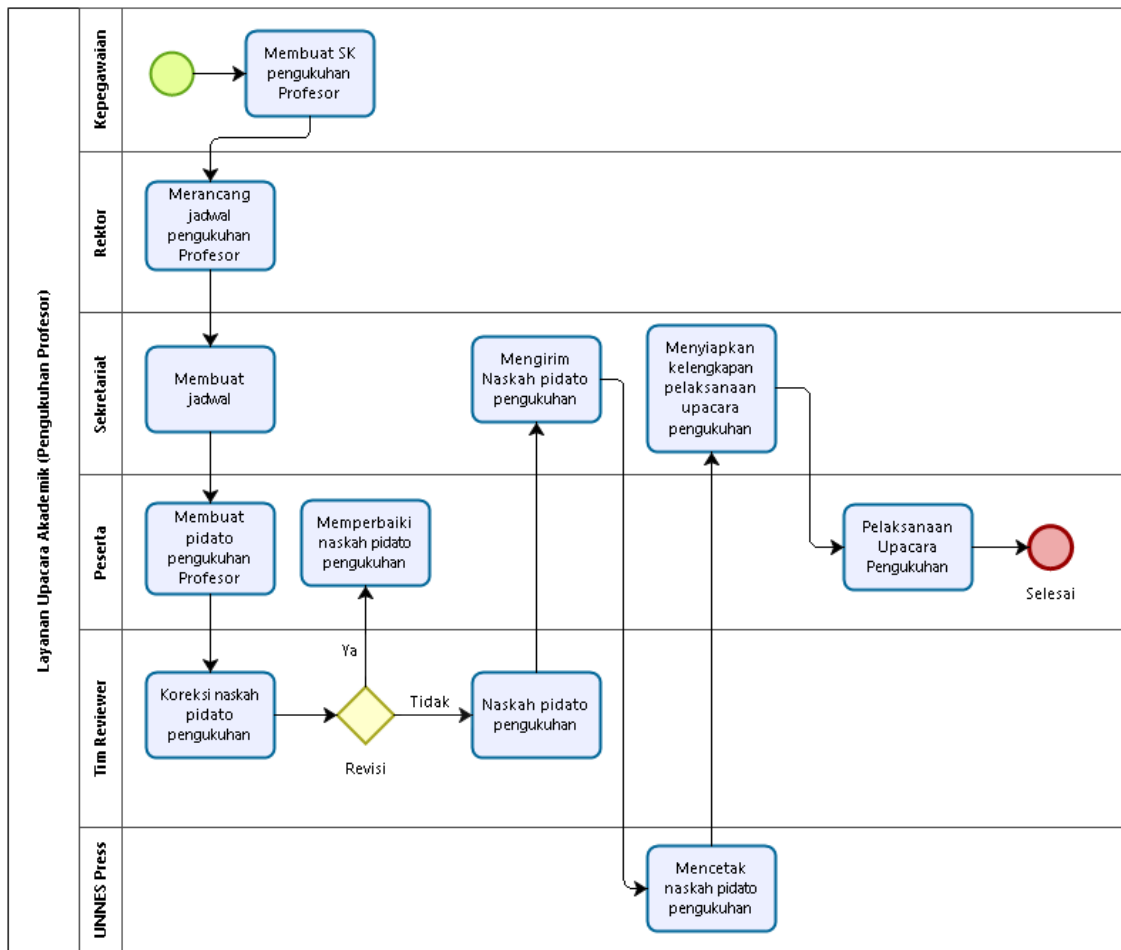

Level 4 Layanan Surat Keterangan PDDIKTI

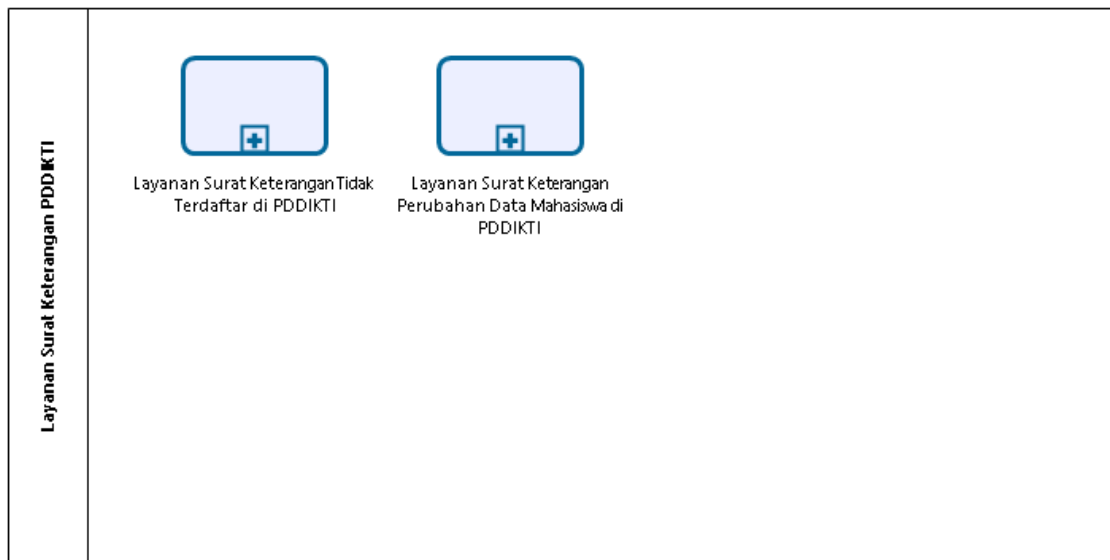

Level 5 Layanan Surat Keterangan Tidak Terdaftar di PDDIKTI

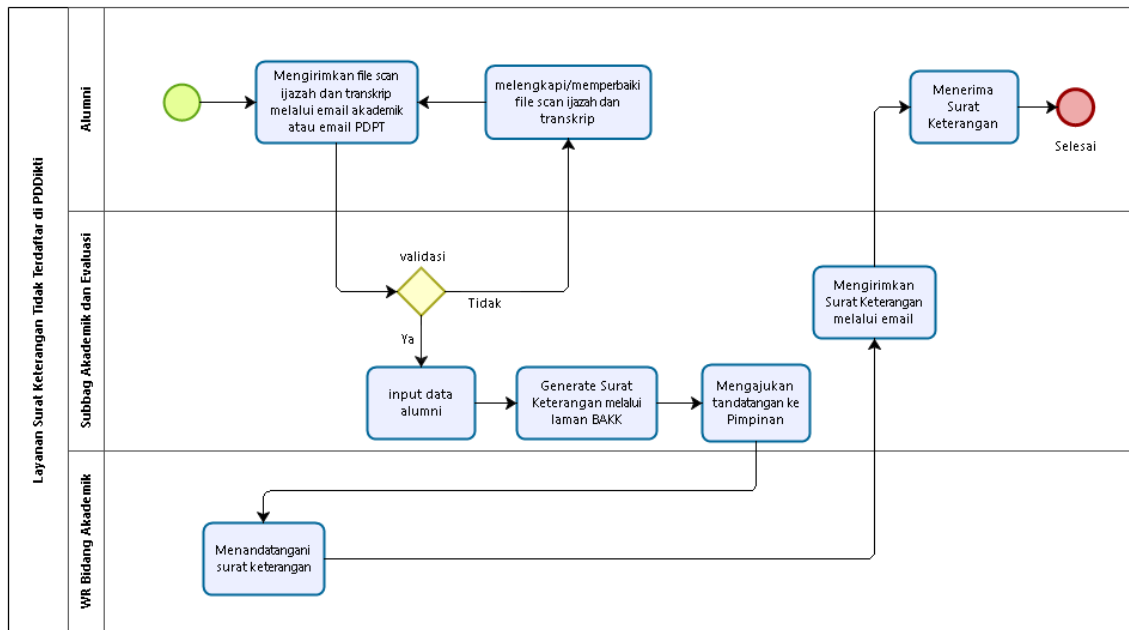

Level 5 Layanan Surat Keterangan Perubahan Data Mahasiswa di PDDIKTI

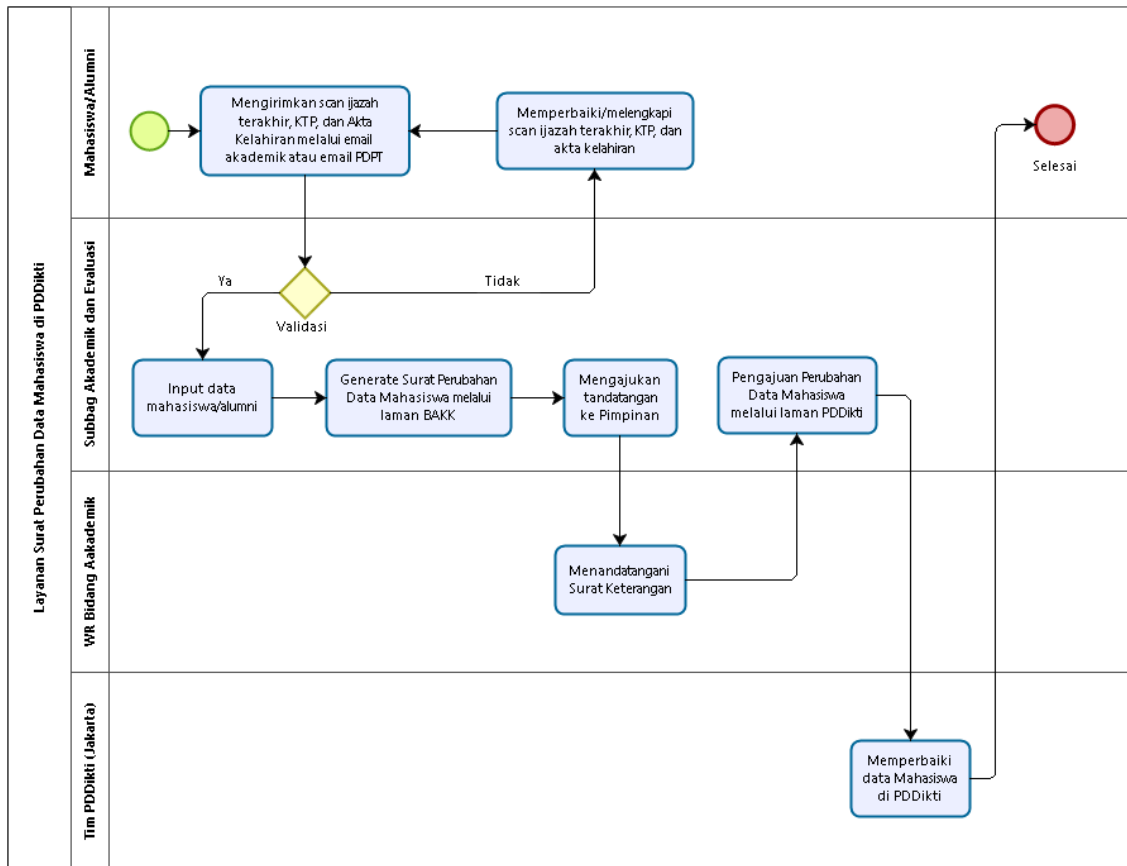

Level 4 Layanan Surat Keterangan Diterima di UNNES

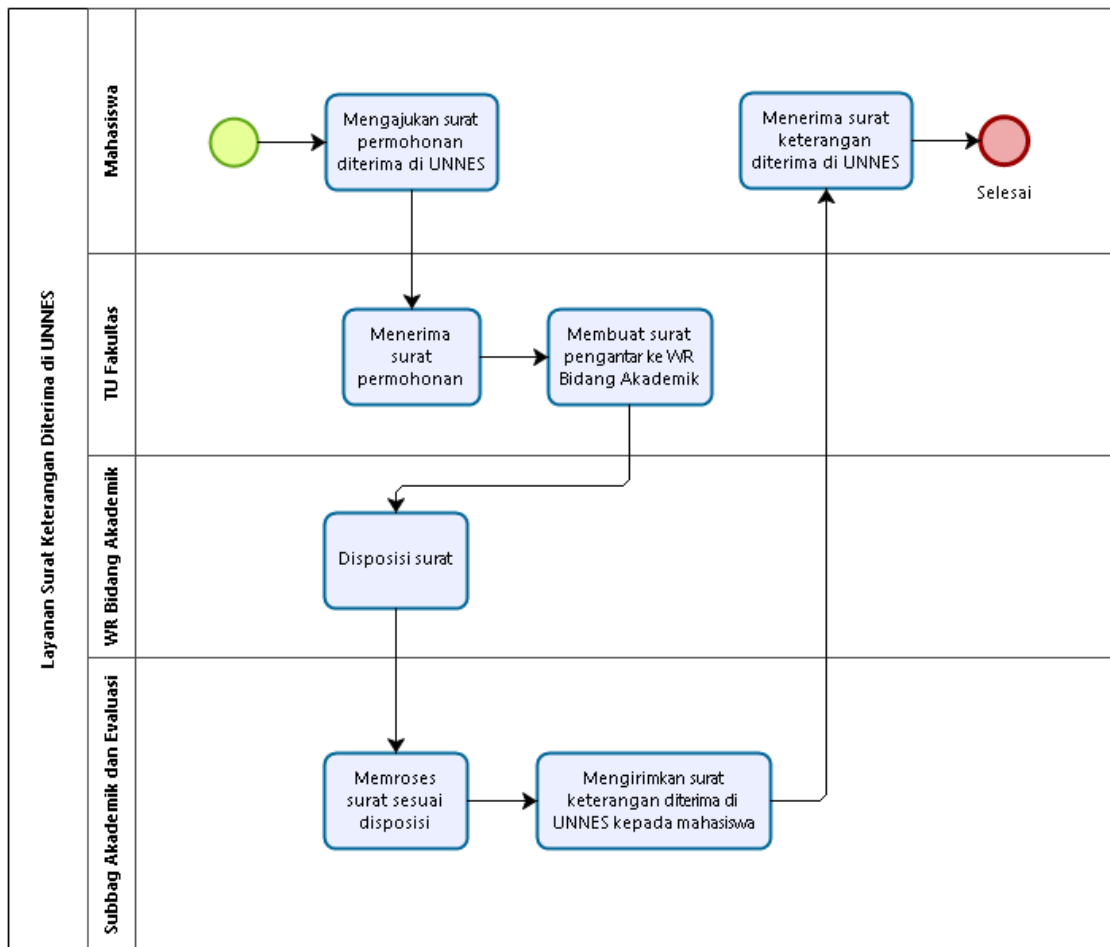

Level 3 Layanan Registrasi dan Statistik

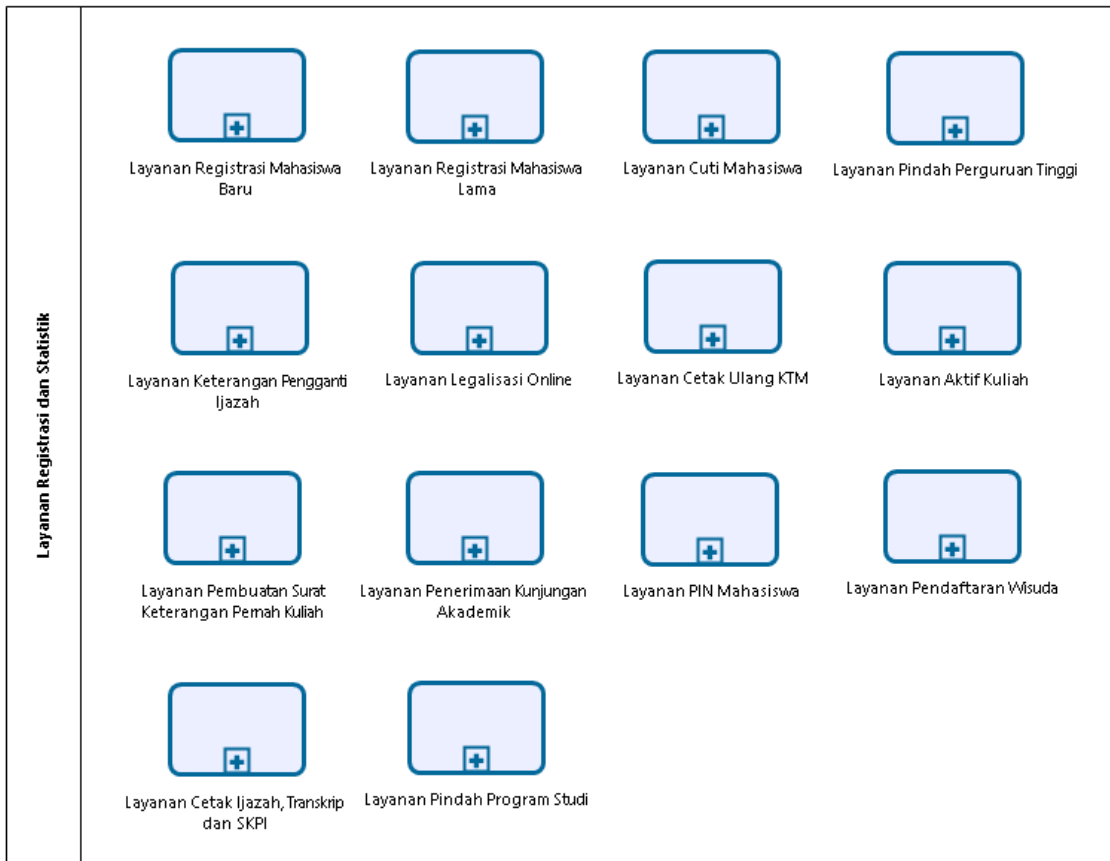

Level 4 Layanan Registrasi Mahasiswa Baru

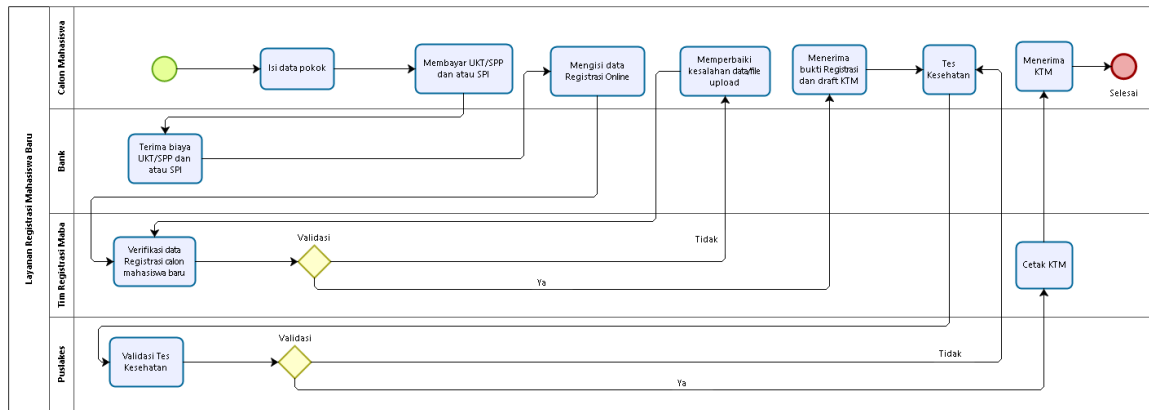

Level 4 Layanan Registrasi Mahasiswa Lama

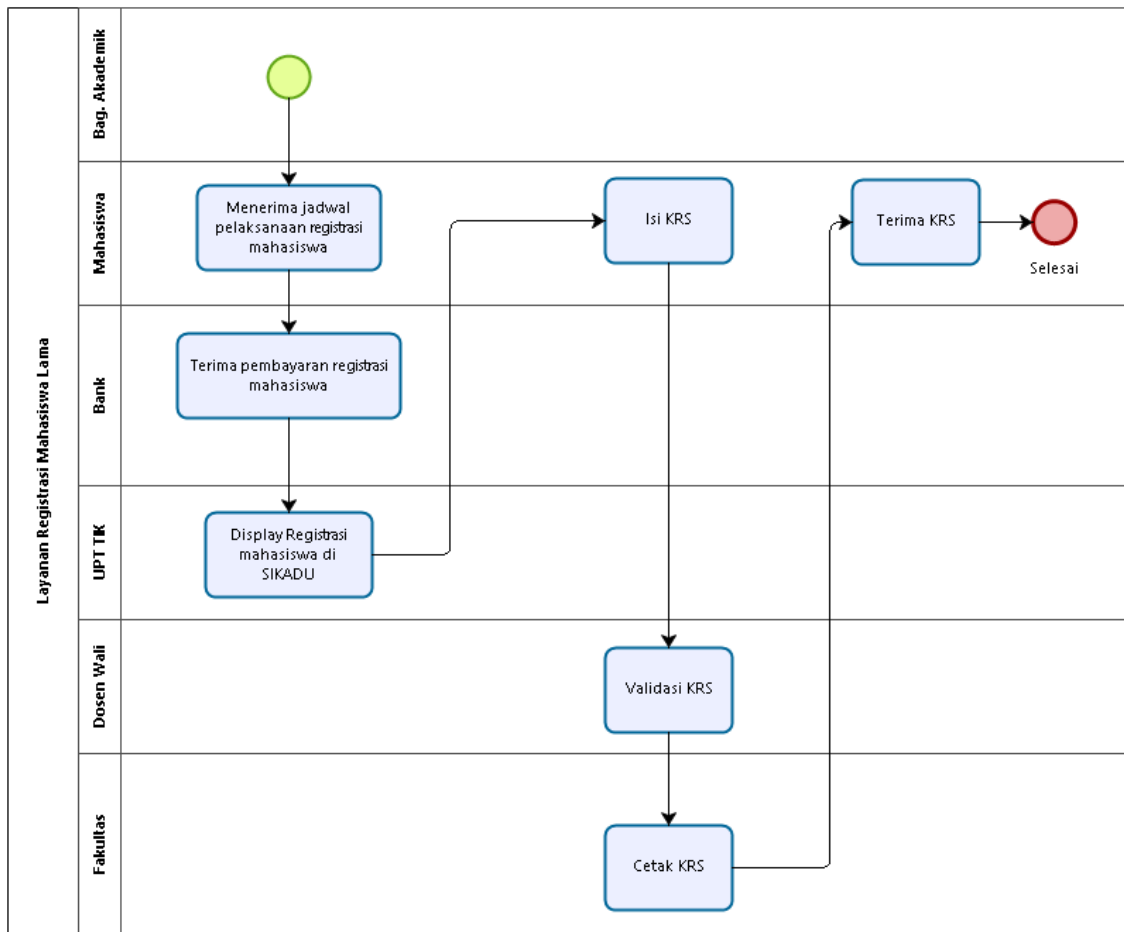

Level 4 Layanan Cuti Mahasiswa

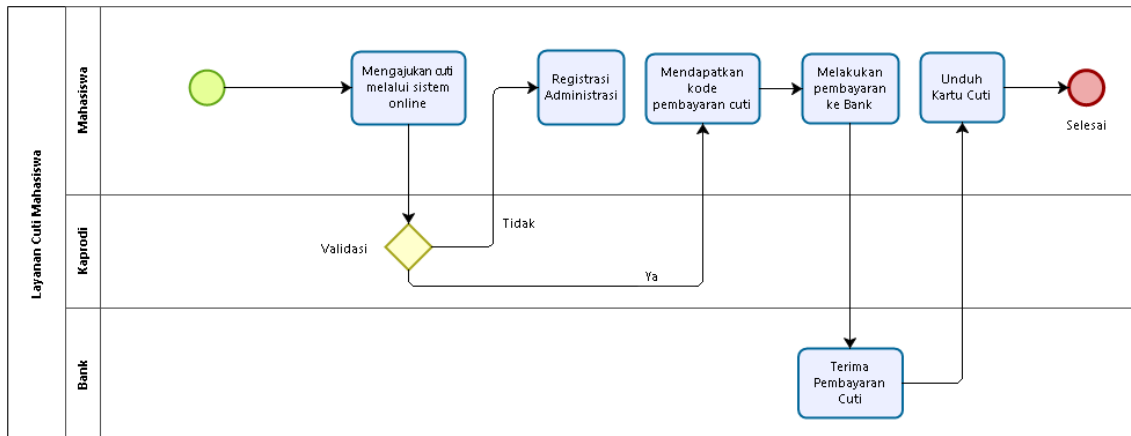

Powered by
bizagi
Modeler

Level 4 Layanan Pindah Perguruan Tinggi

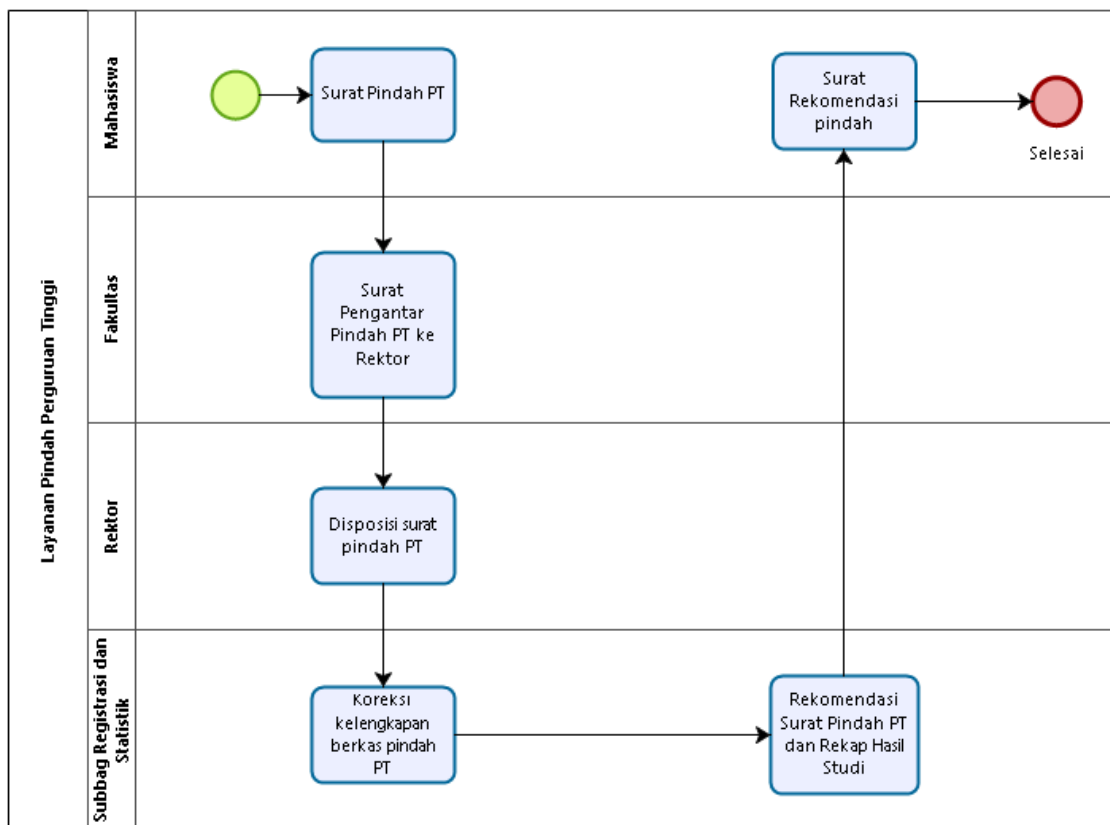

Powered by
bizagi
Modeler

Level 4 Layanan Keterangan Pengganti Ijazah

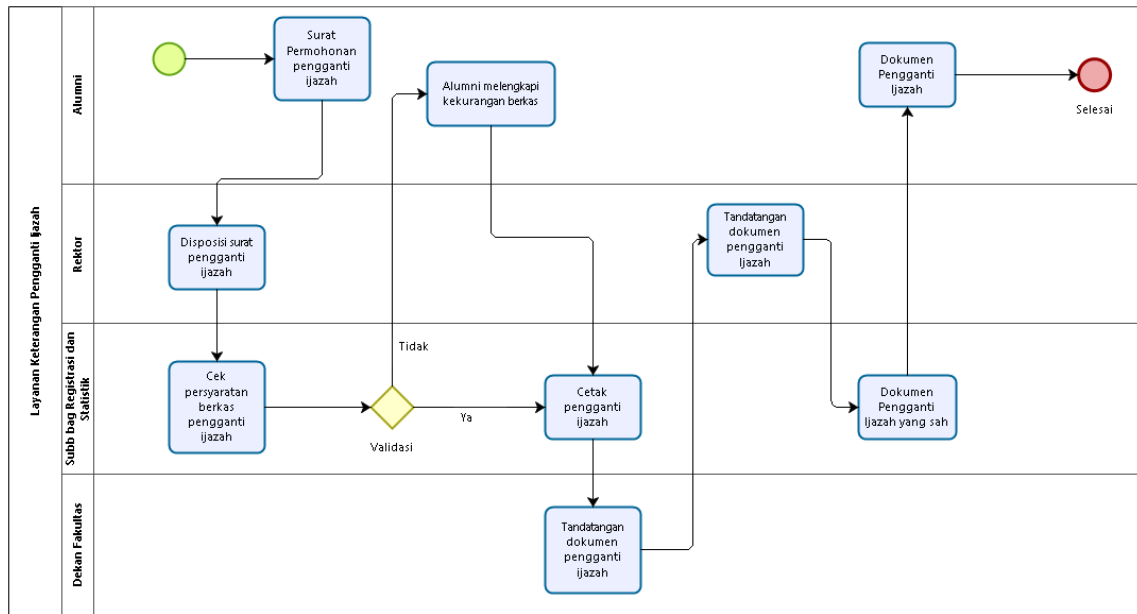

Level 4 Layanan Legalisasi Online

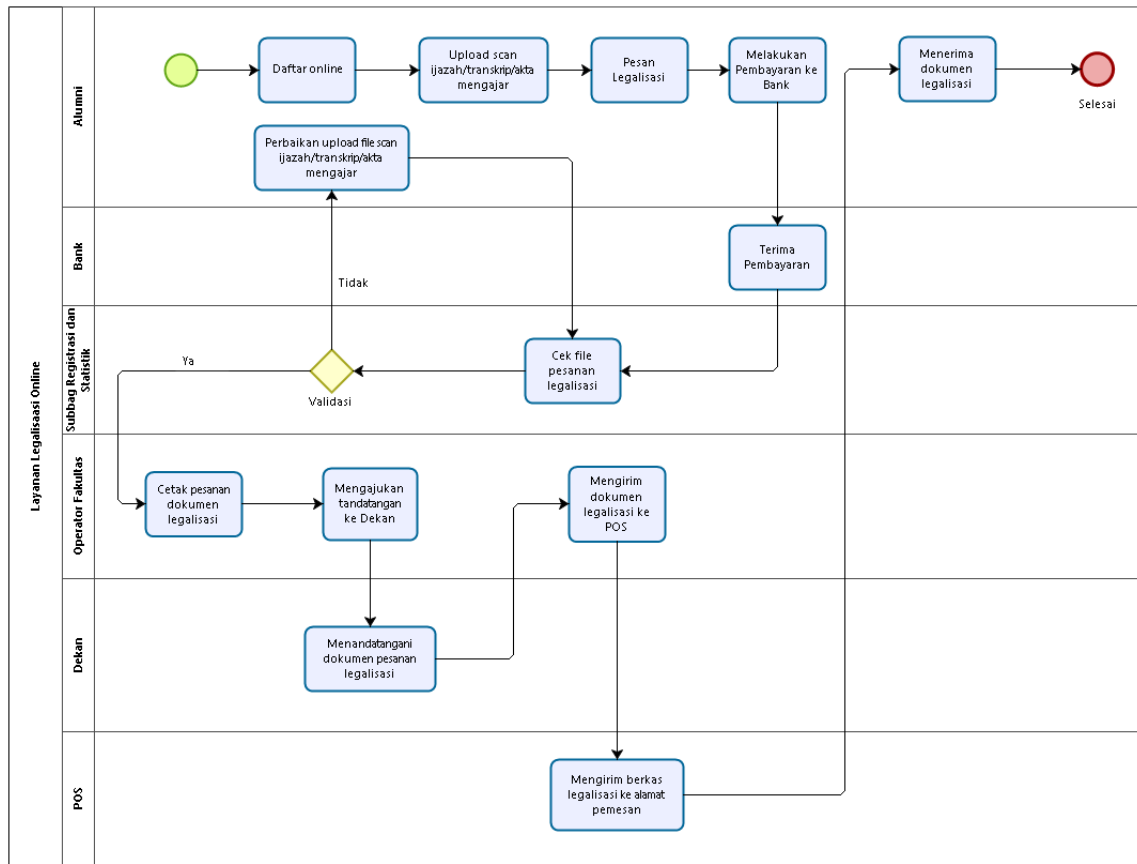

Level 4 Layanan Cetak Ulang KTM

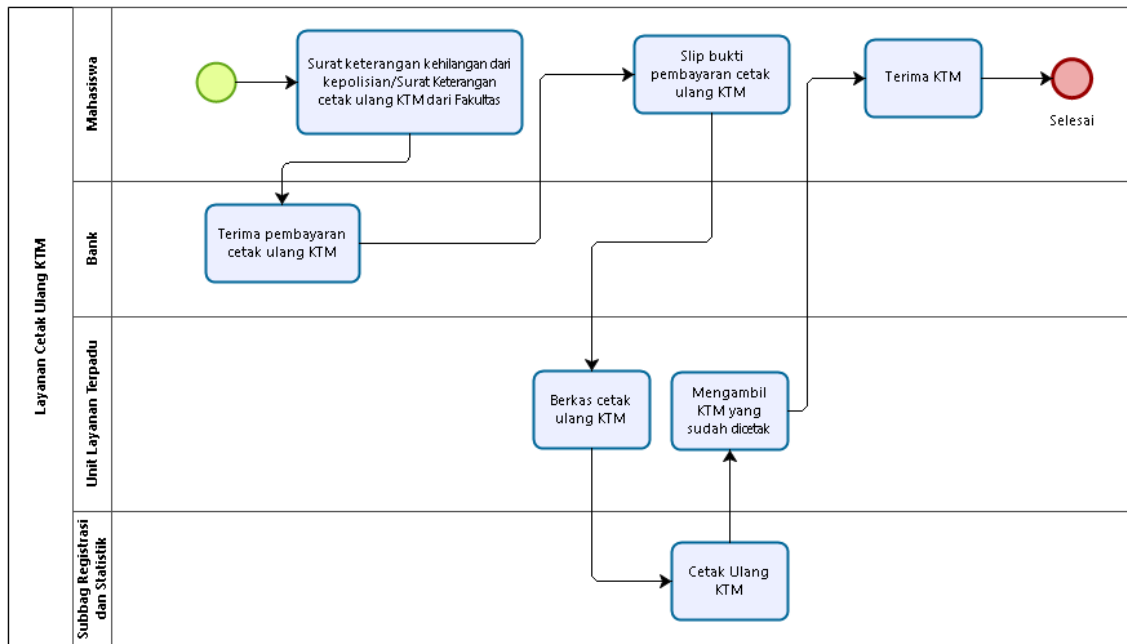

Level 4 Layanan Aktif Kuliah

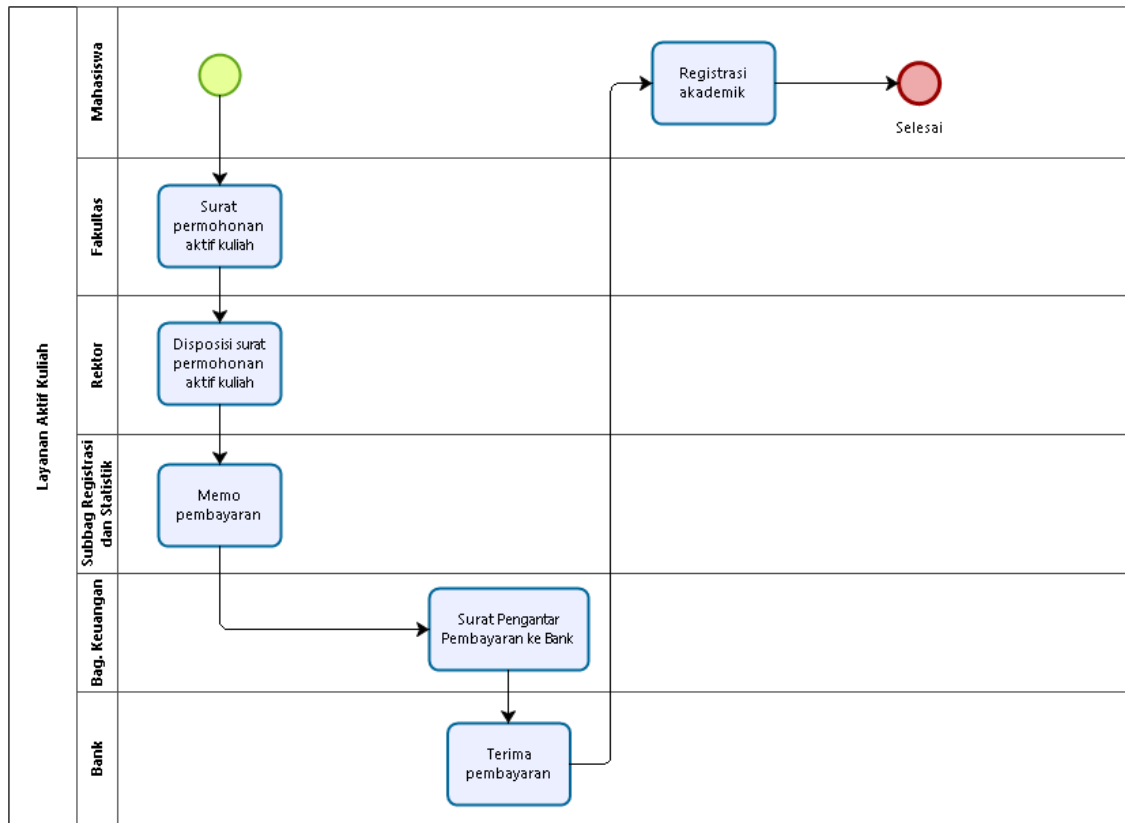

Level 4 Layanan Pembuatan Surat Keterangan Pernah Kuliah

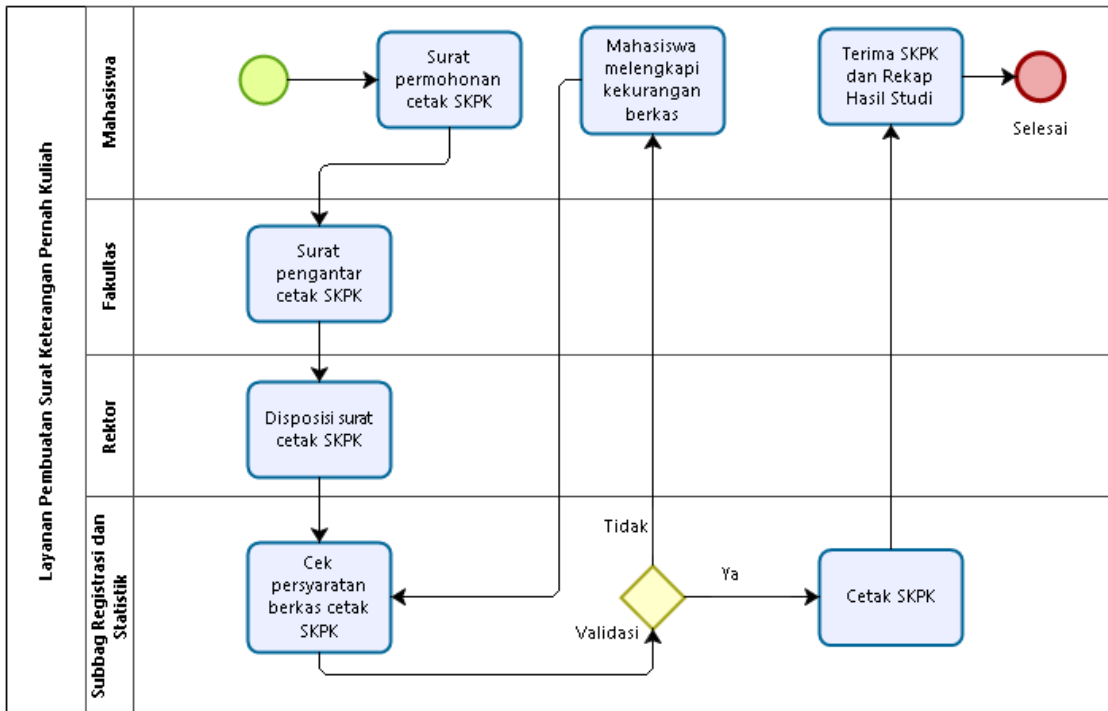

Level 4 Layanan Penerimaan Kunjungan Akademik

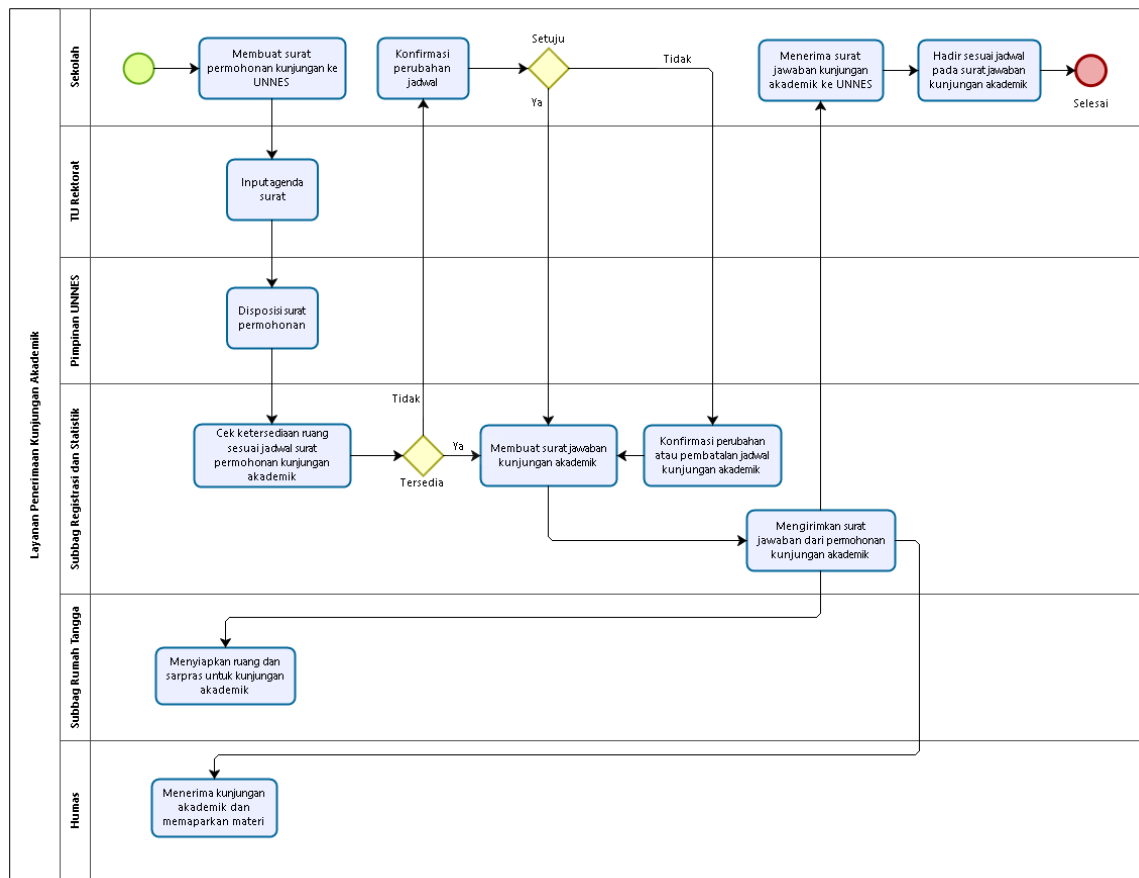

Level 4 Layanan PIN Mahasiswa

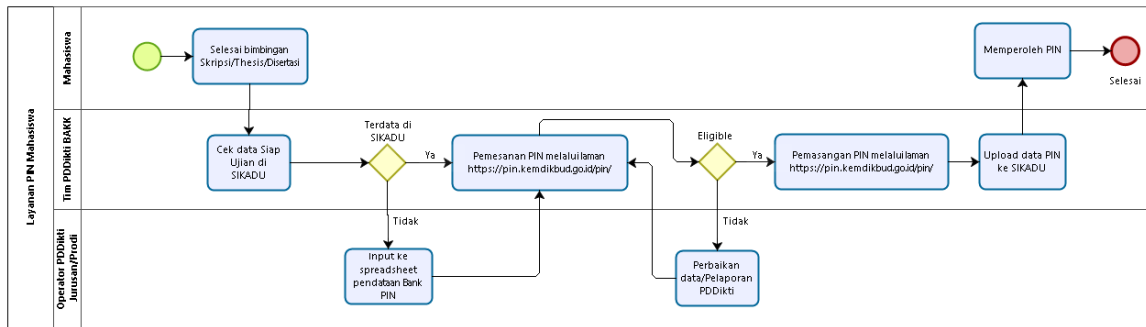

Powered by
bizagi
Modeler

Level 4 Layanan Pendaftaran Wisuda

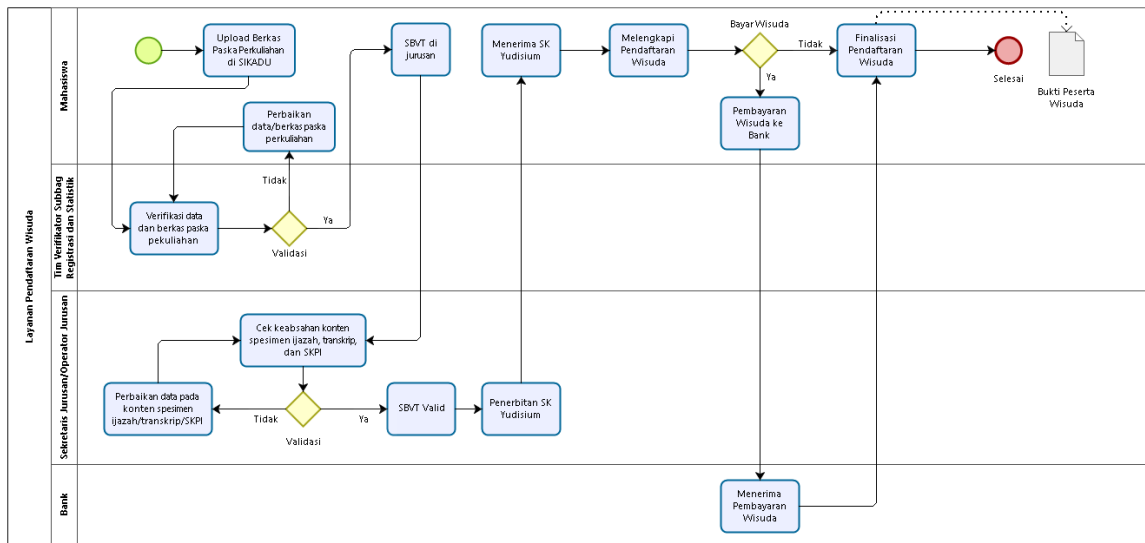

Level 4 Layanan Cetak Ijazah, Transkrip dan SKPI

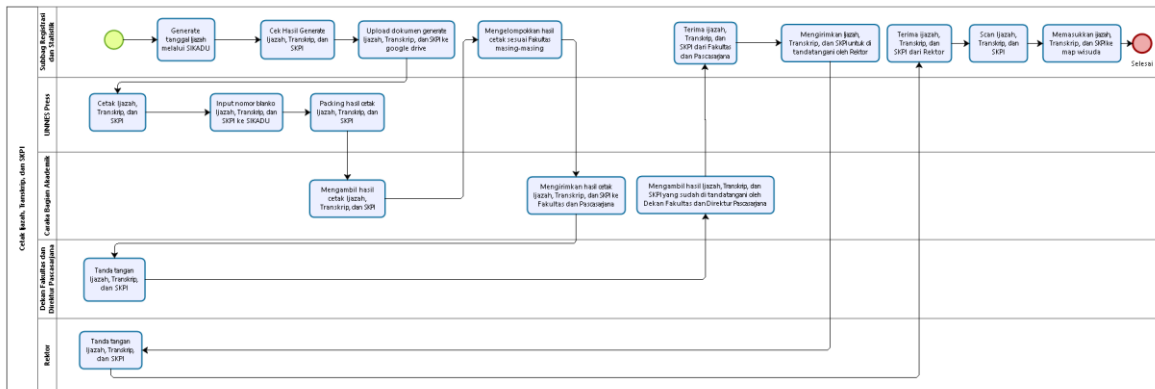

Level 4 Layanan Pindah Program Studi

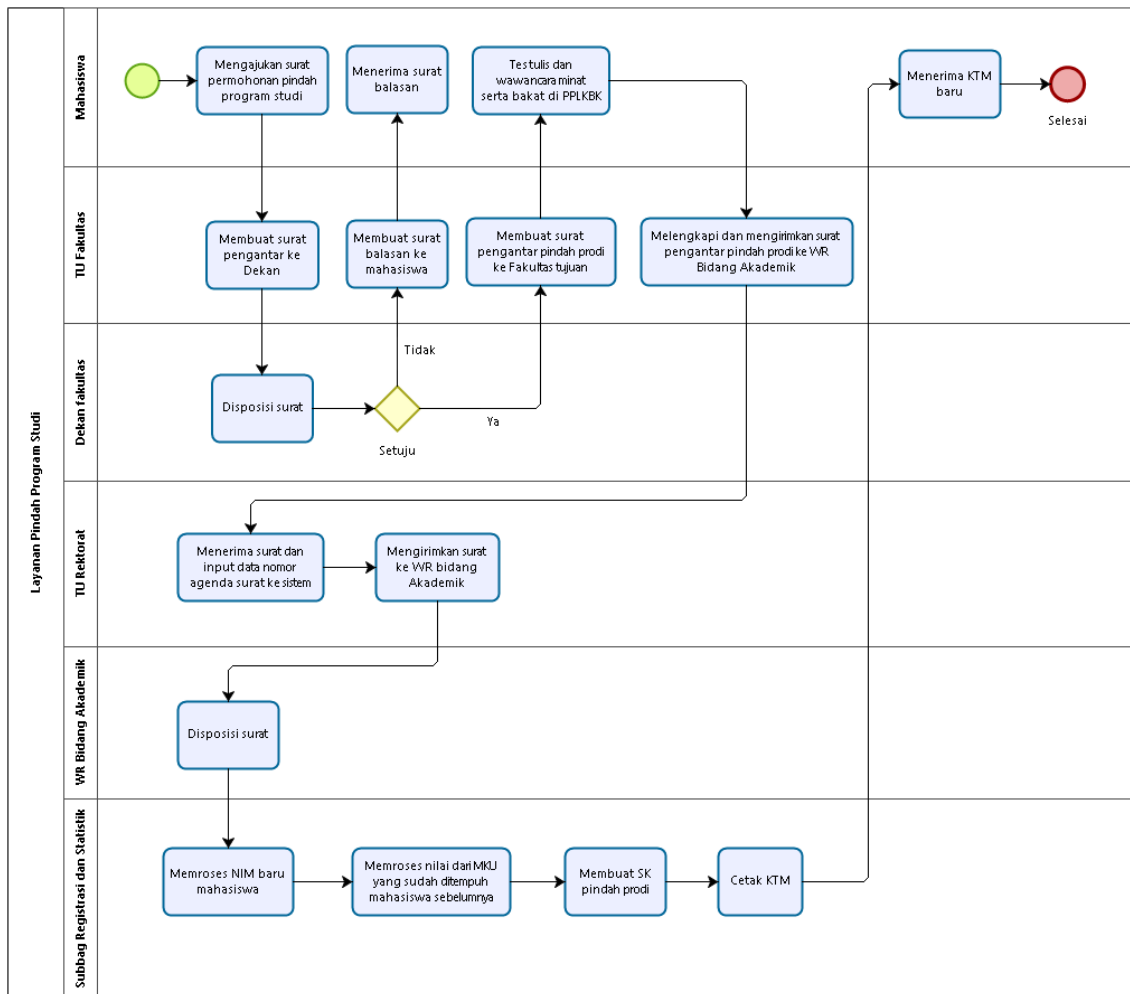

Level 2 Layanan Kemahasiswaan

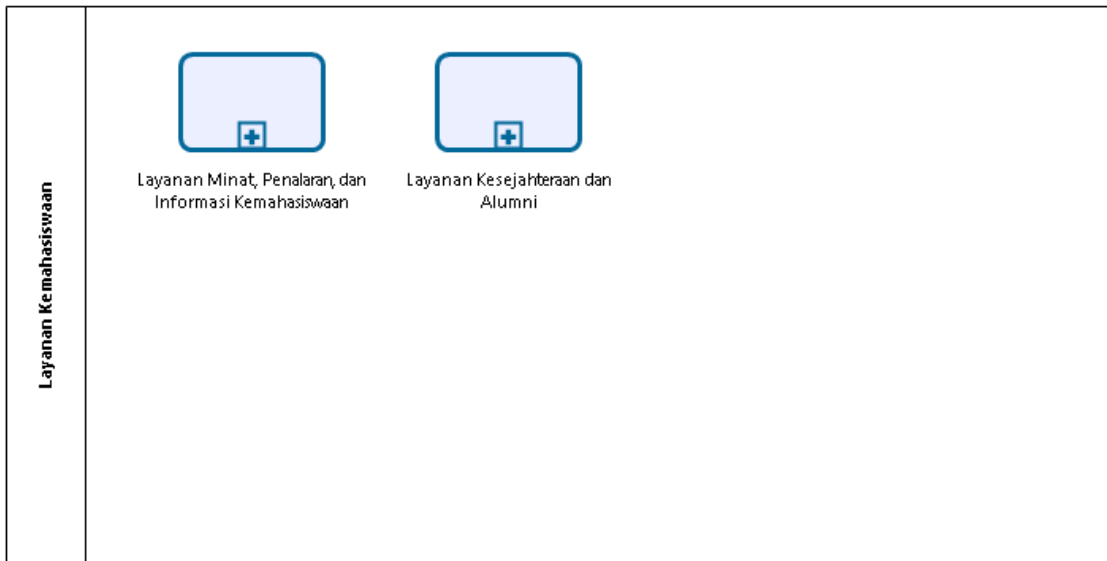

Powered by
bizagi
Modeler

Level 3 Layanan Minat, Penalaran dan Informasi Kemahasiswaan

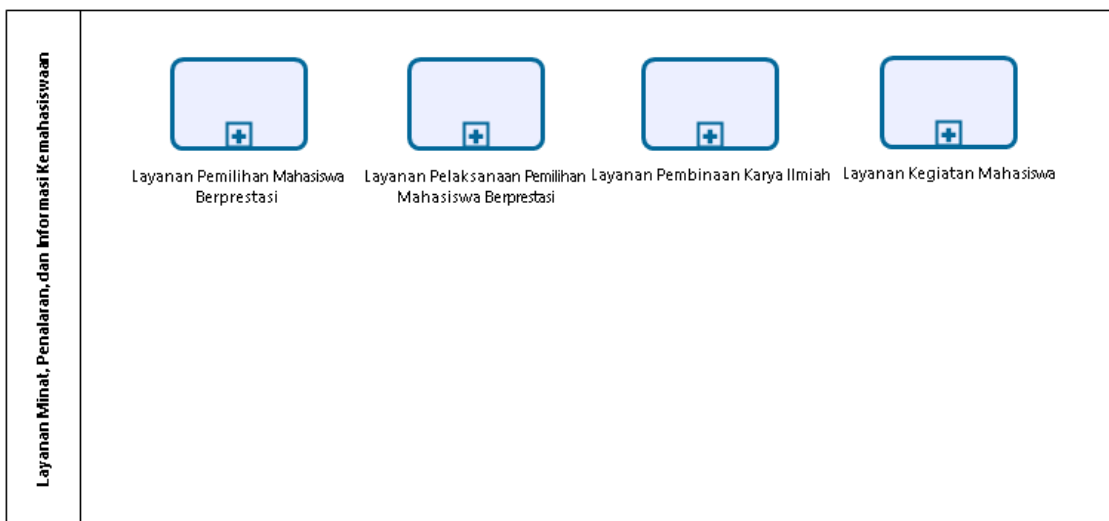

Powered by
bizagi
Modeler

Level 4 Layanan Pemilihan Mahasiswa Berprestasi

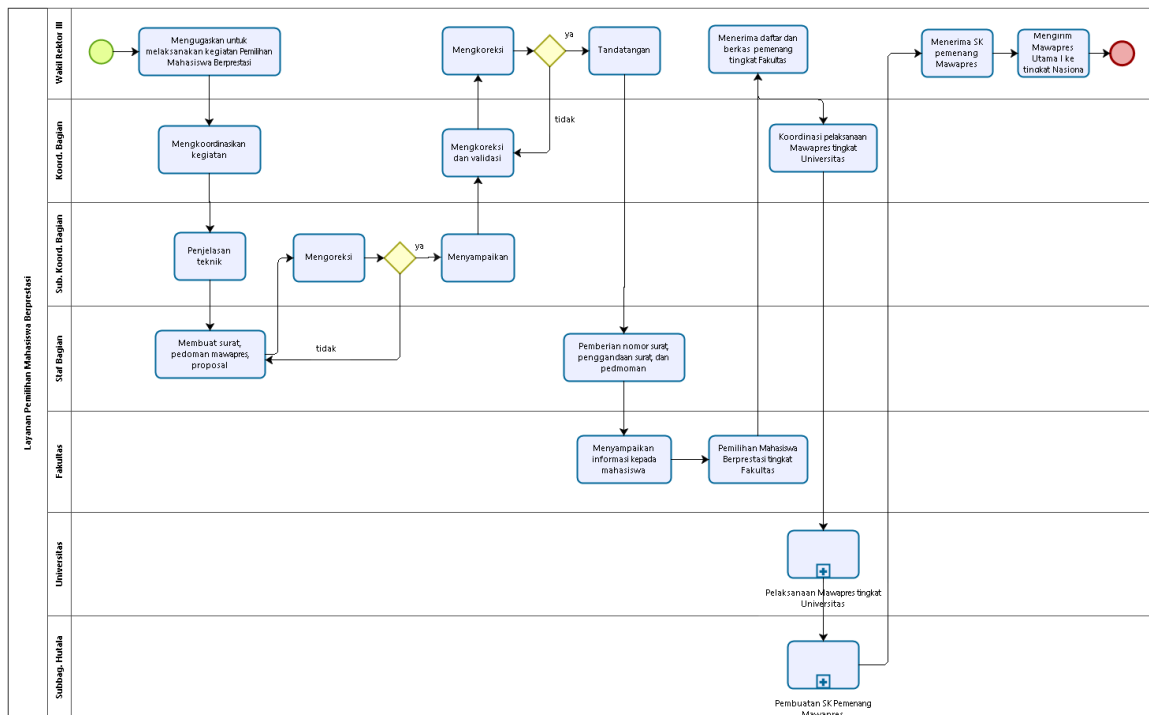

Level 4 Layanan Pelaksanaan Pemilihan Mahasiswa Berprestasi

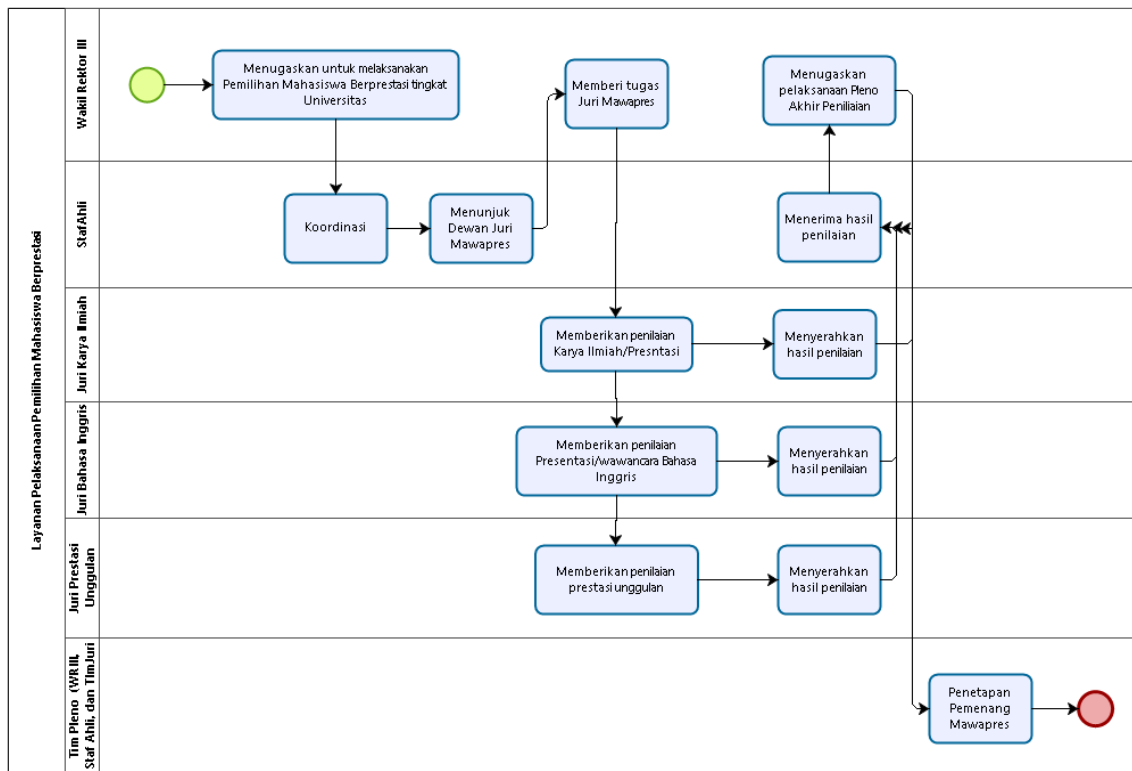

Level 4 Layanan Pembinaan Karya Ilmiah

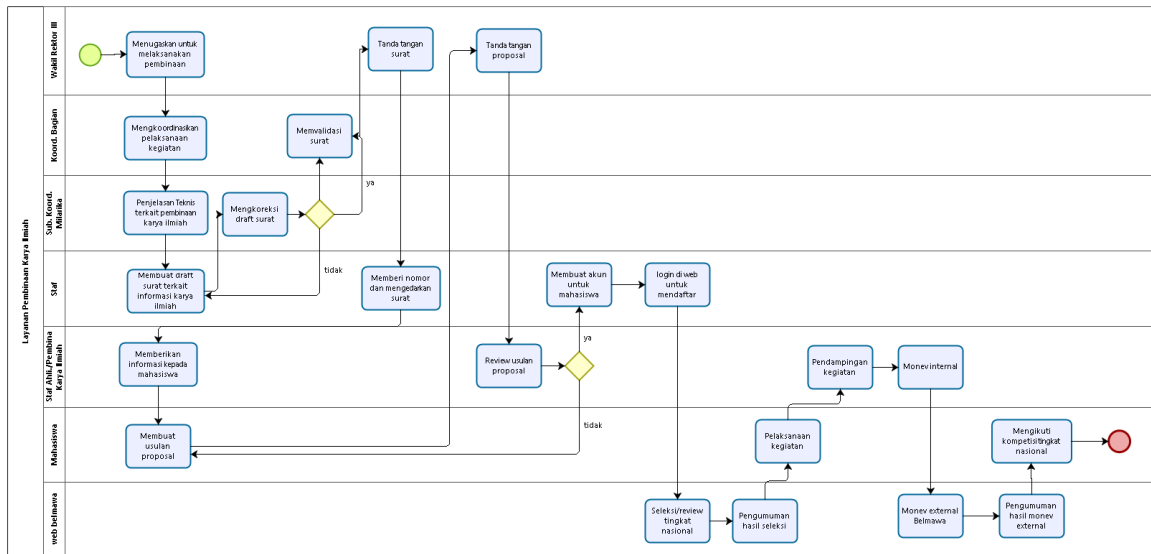

Level 4 Layanan Kegiatan Mahasiswa

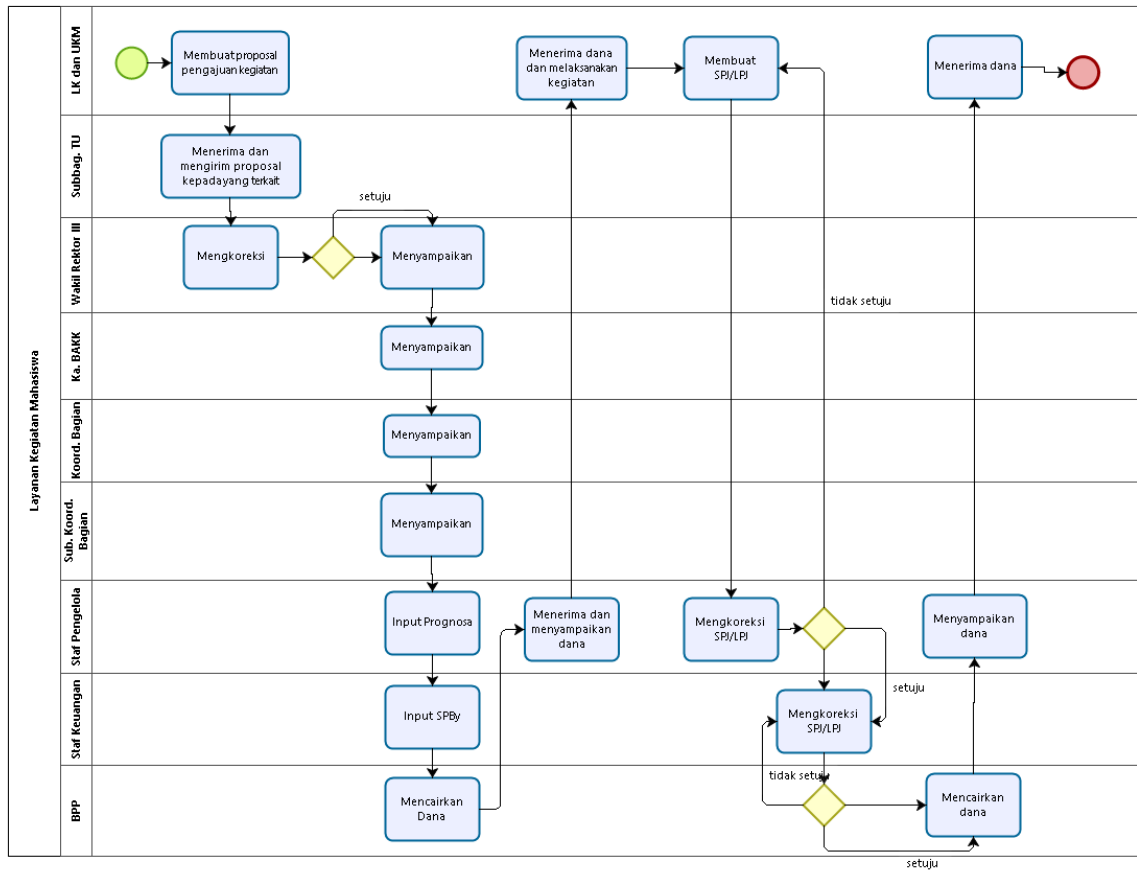

Level 3 Layanan Kesejahteraan dan Alumni

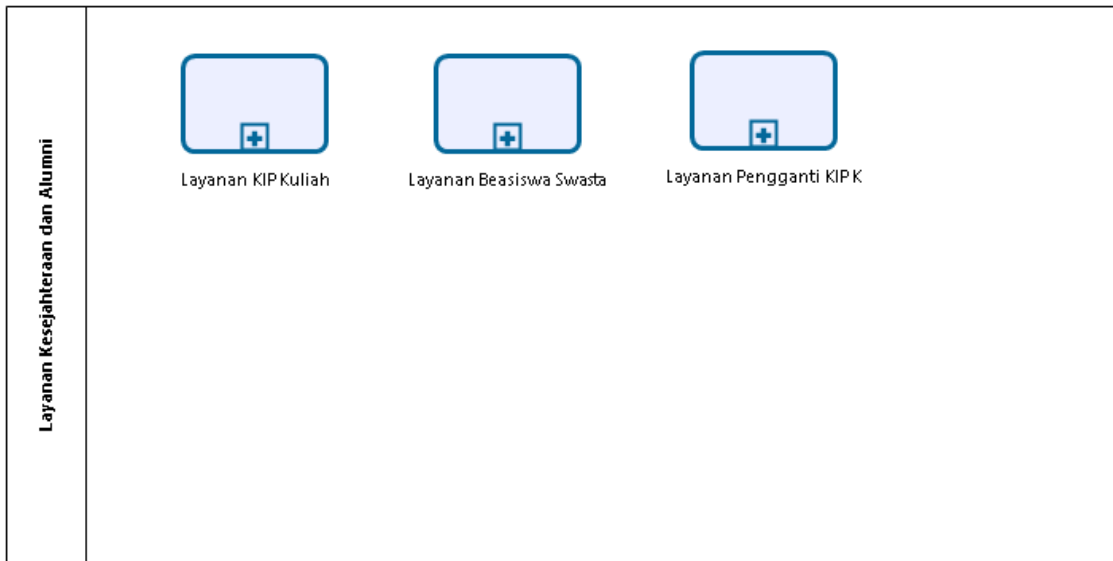

Level 4 Layanan KIP Kuliah

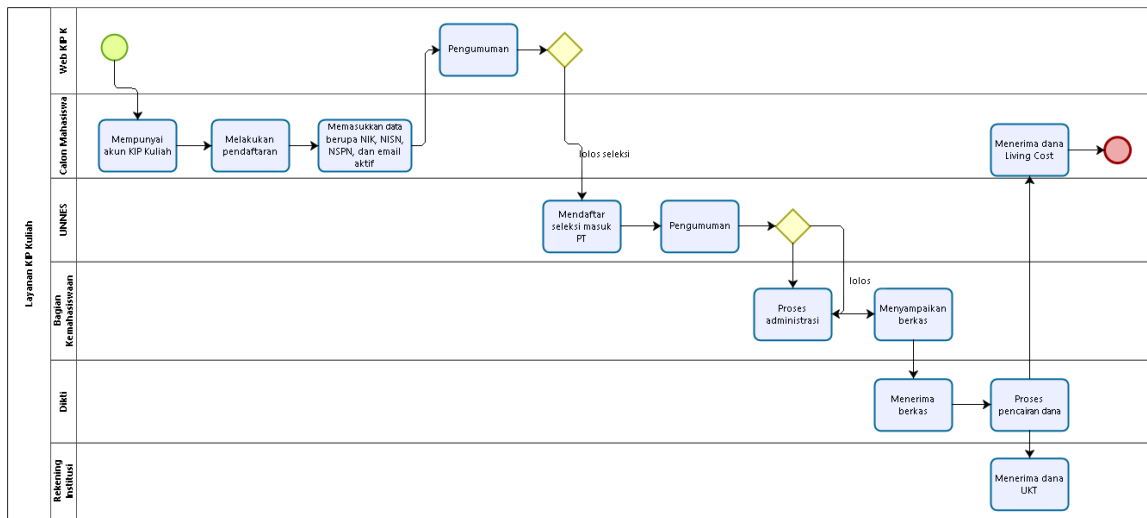

Level 4 Layanan Beasiswa Swasta

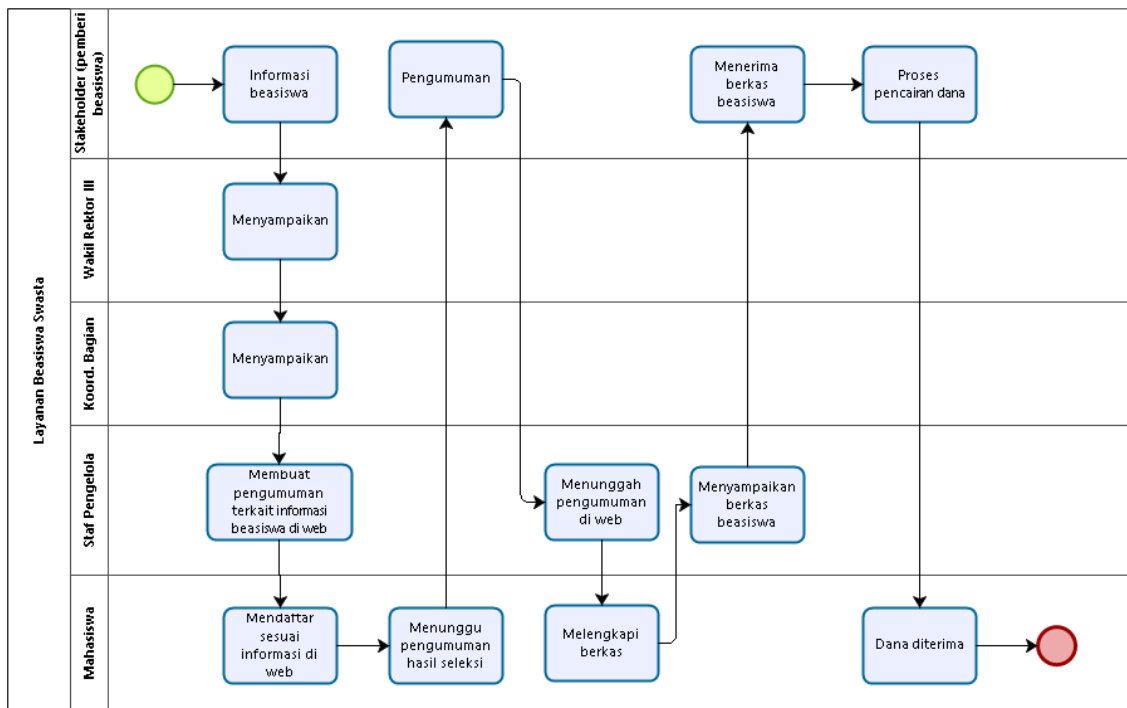

Level 4 Layanan Pengganti KIP Kuliah

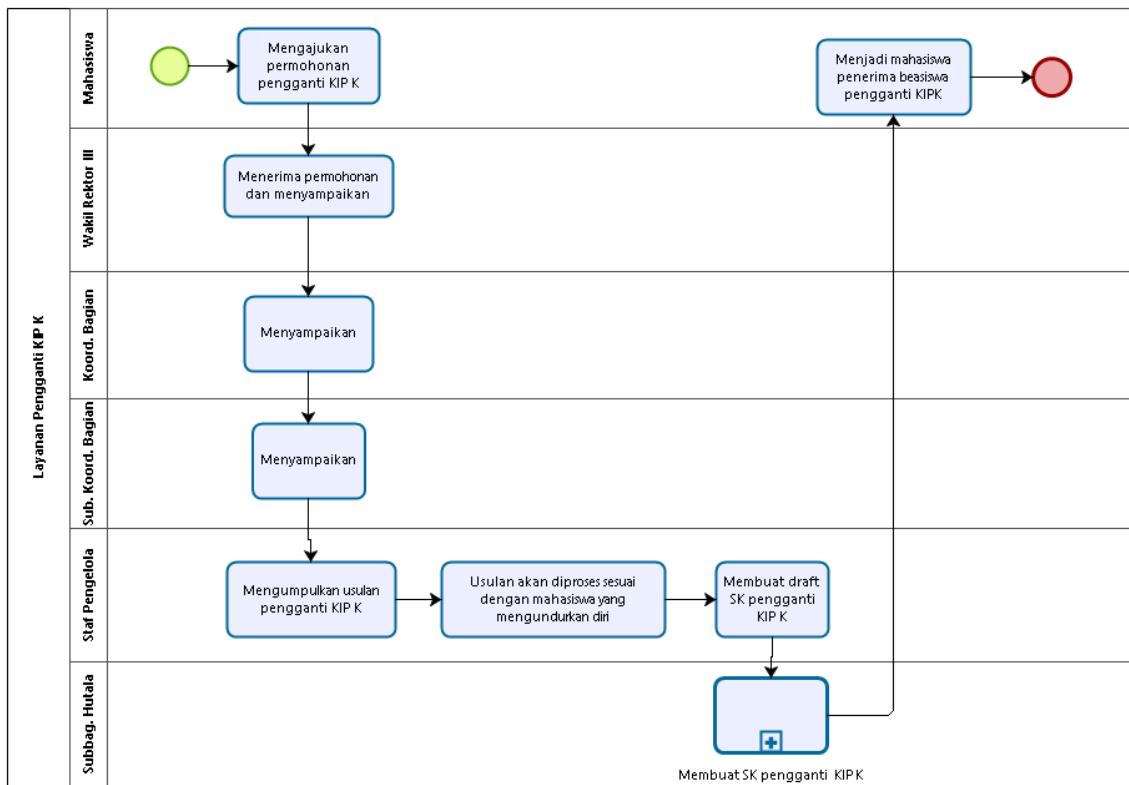

Level 2 Layanan Kerjasama



Powered by
bizagi
Modeler

Level 3 Layanan Kerjasama Dalam Negeri

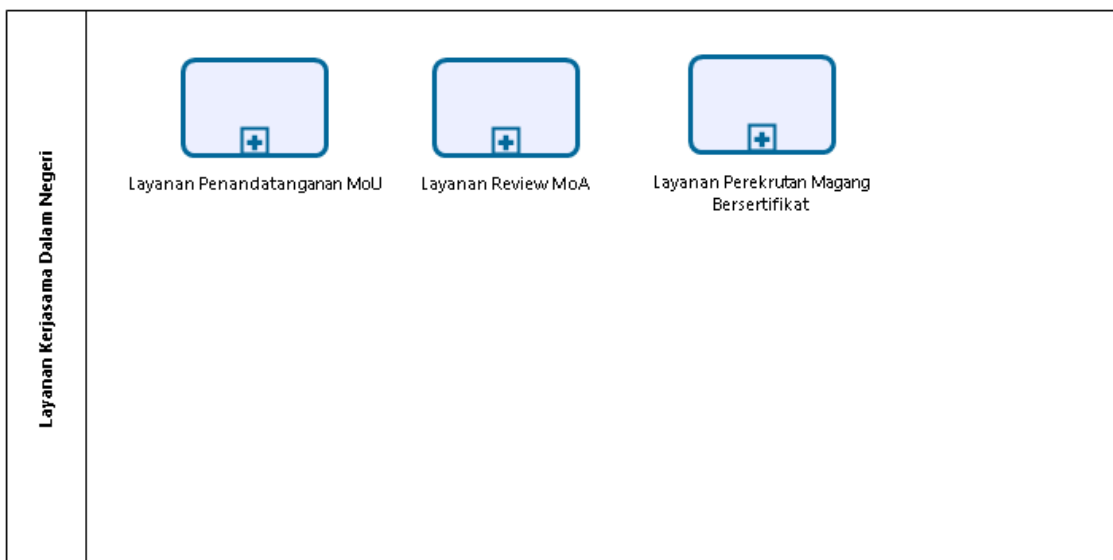

Powered by
bizagi
Modeler

Level 4 Layanan Penandatanganan MoU KSDN

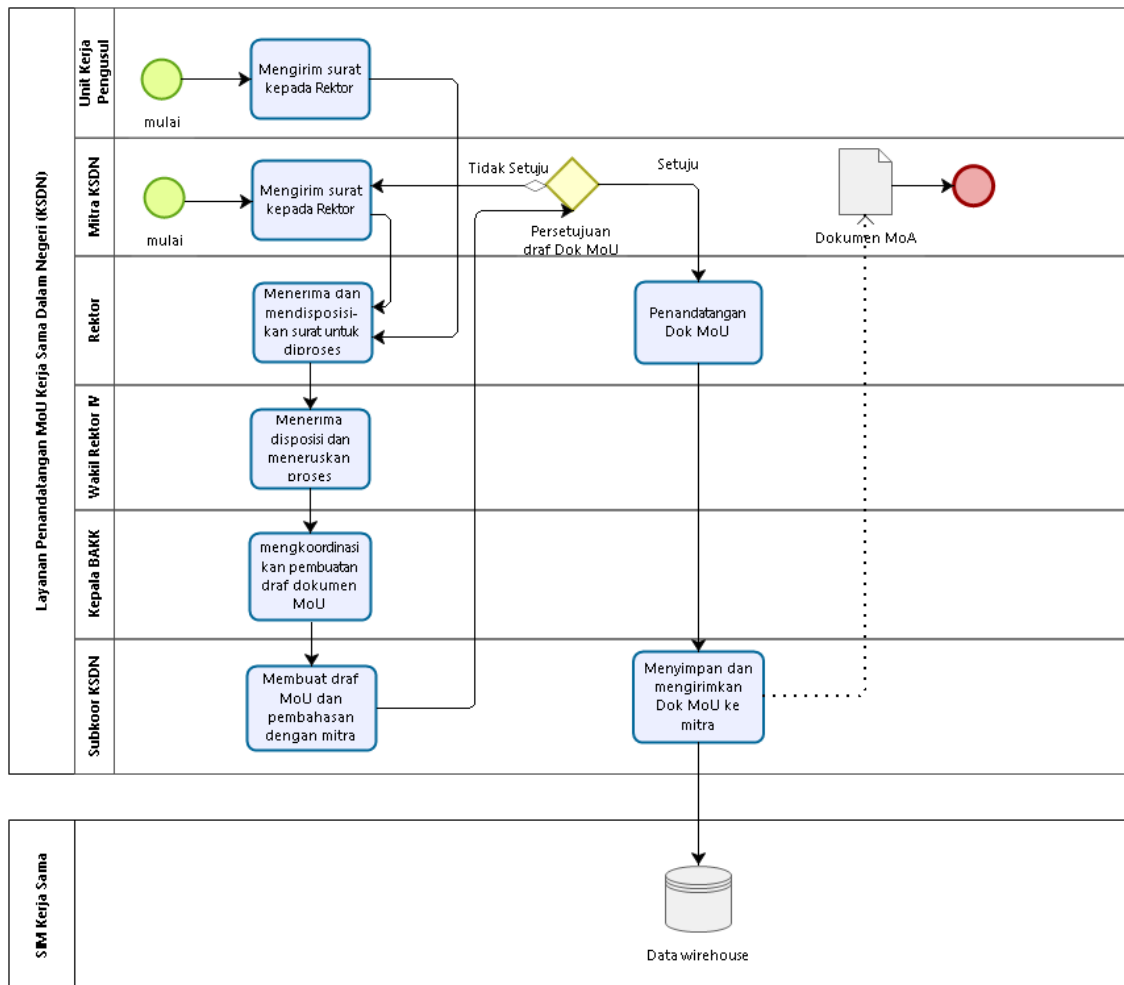

Level 4 Layanan Review MoA KSDN

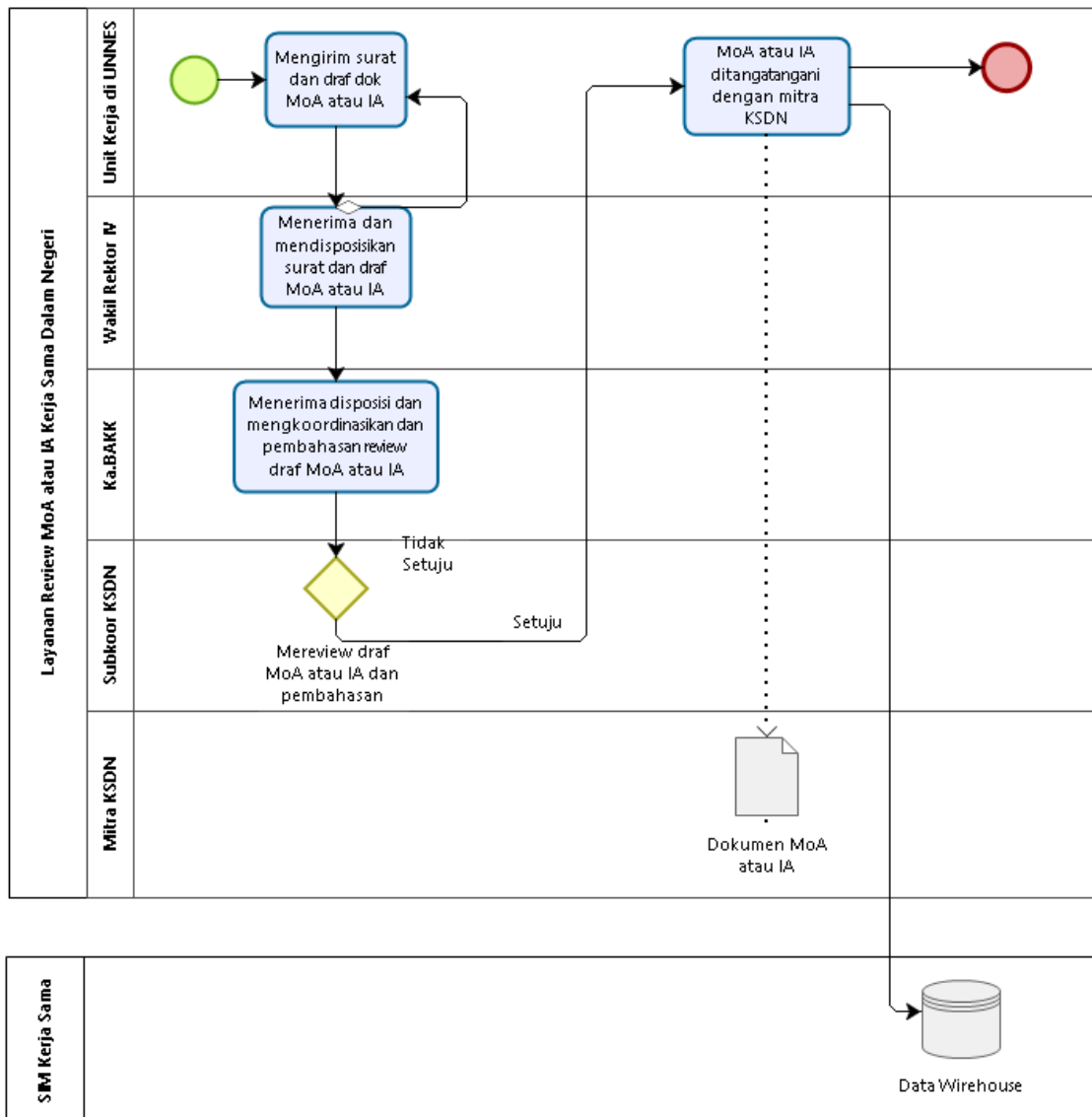

Level 4 Layanan Perekrutan Magang Bersertifikat

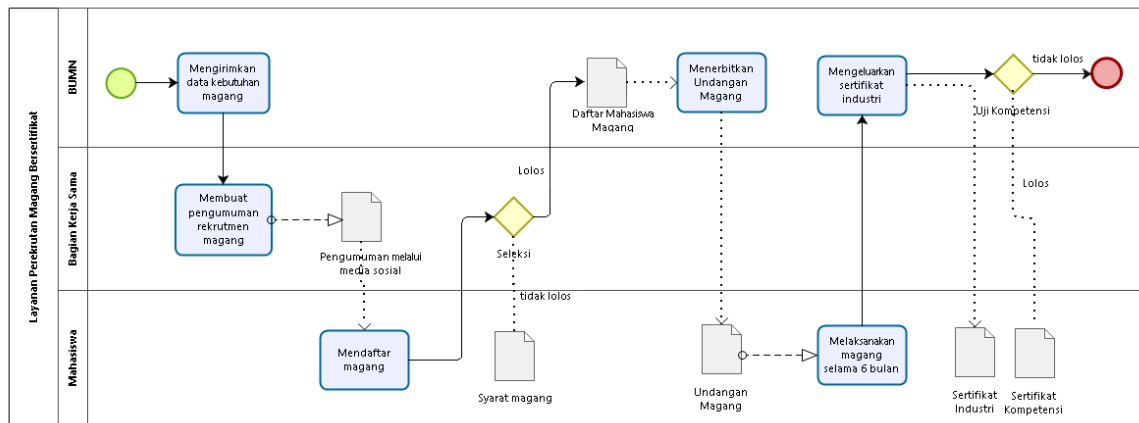

Level 3 Layanan Kerjasama Luar Negeri

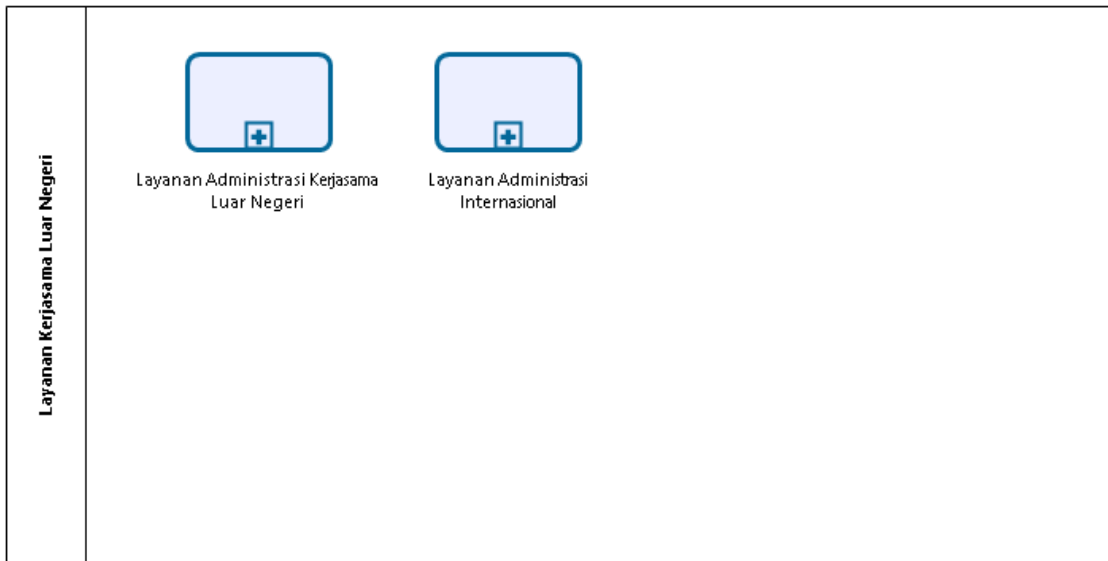

Level 4 Layanan Administrasi KSLN

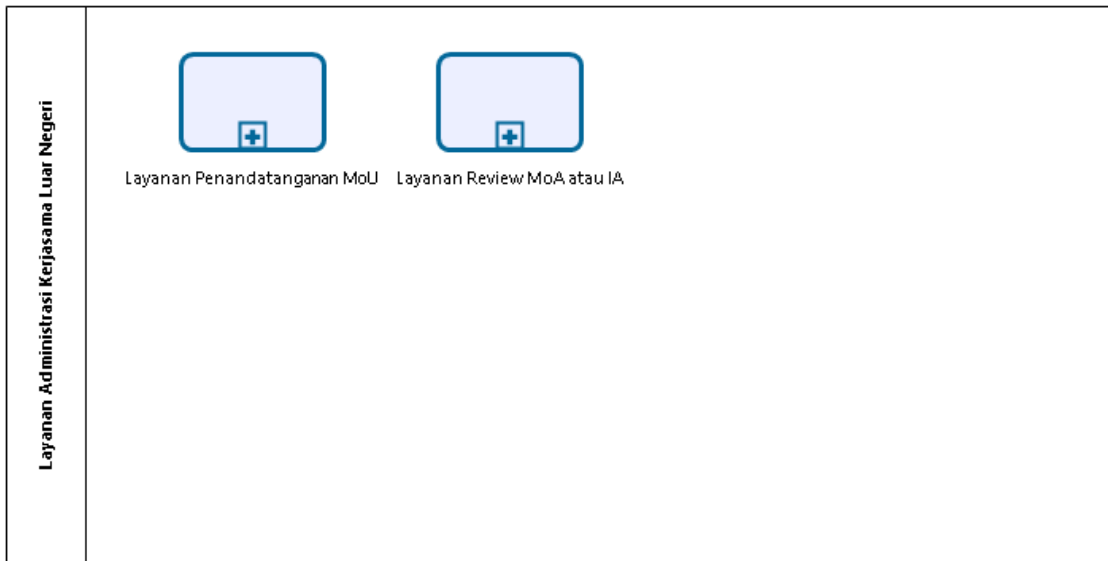

Level 5 Layanan Penandatanganan MoU KSLN

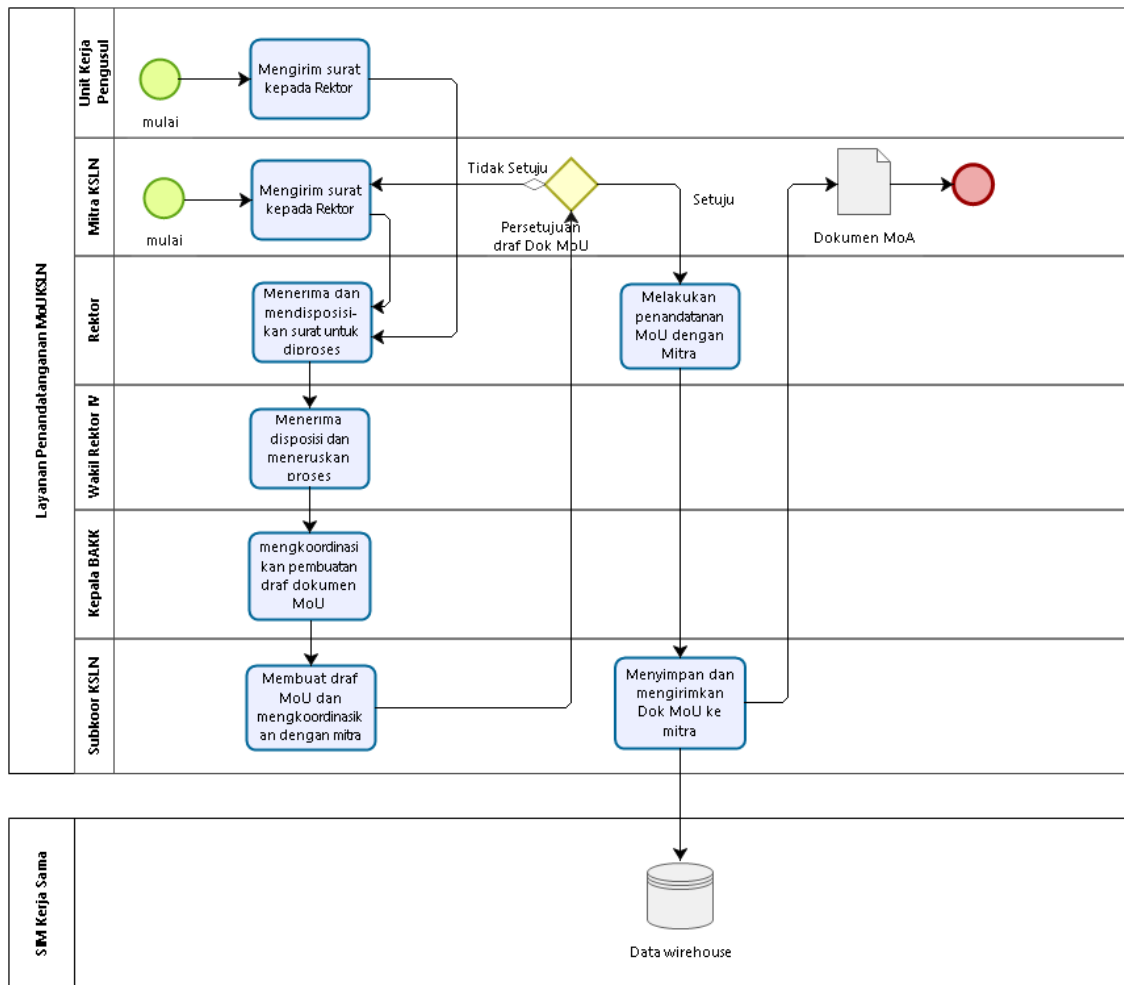

Level 5 Layanan Review MoA atau IA KSLN

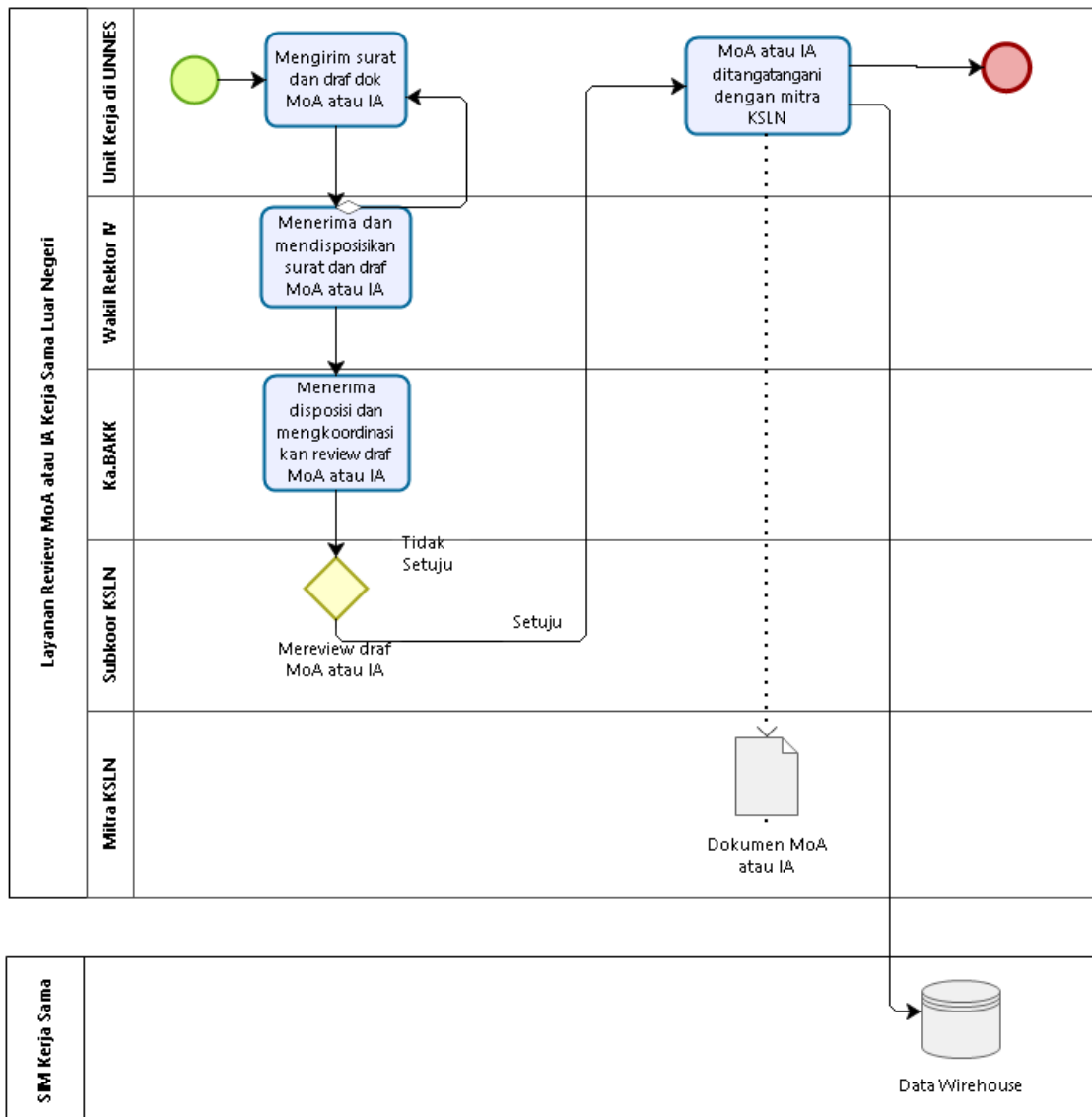

Level 4 Layanan Administrasi Internasional

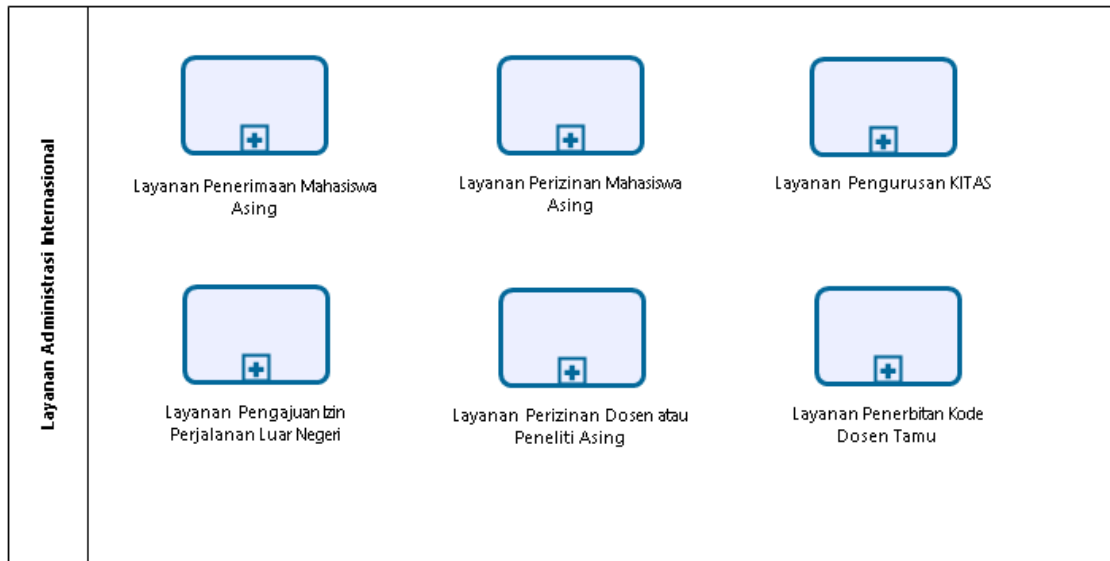

Level 5 Layanan Penerimaan Mahasiswa Asing

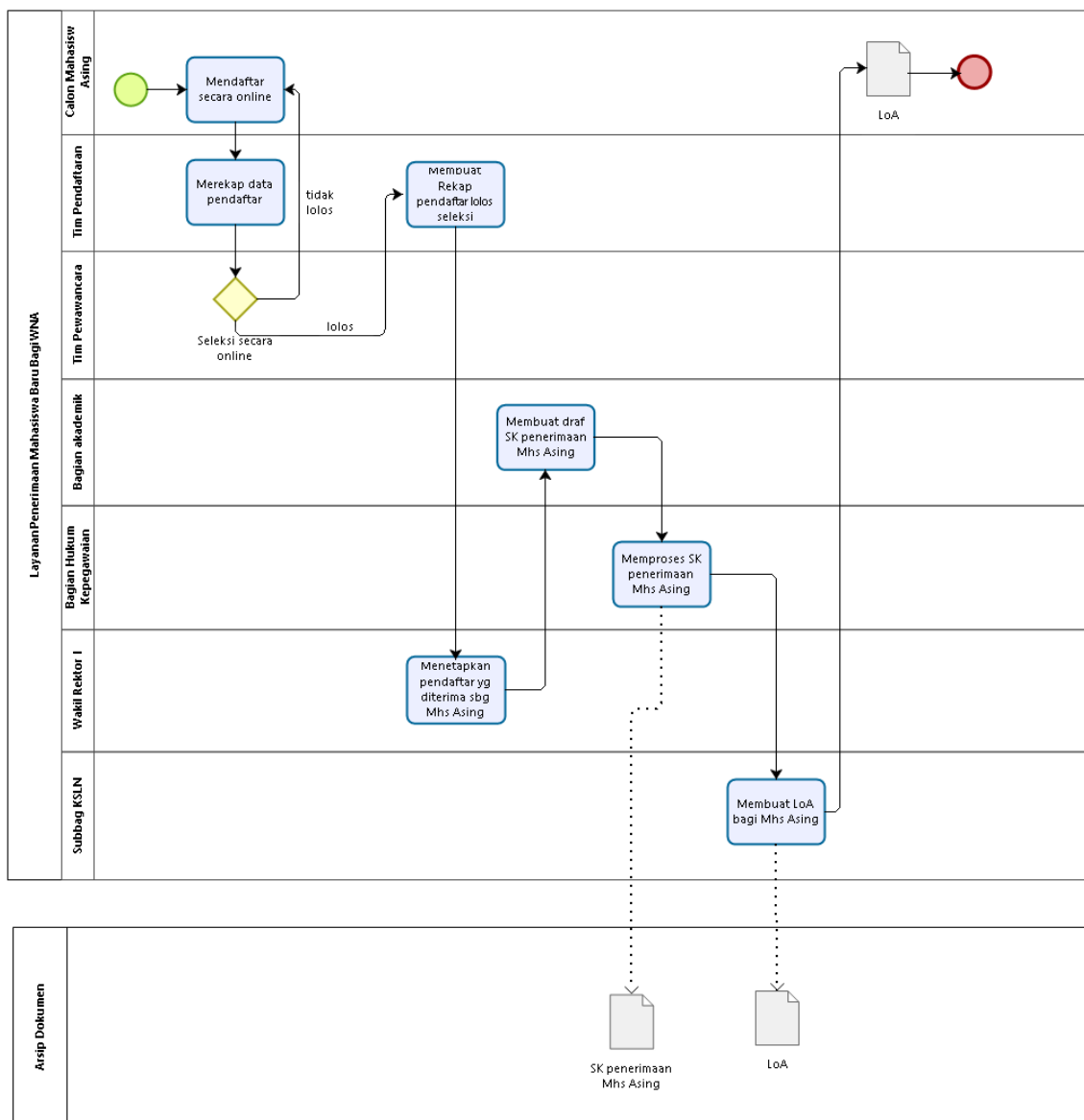

Level 5 Layanan Perizinan Mahasiswa Asing

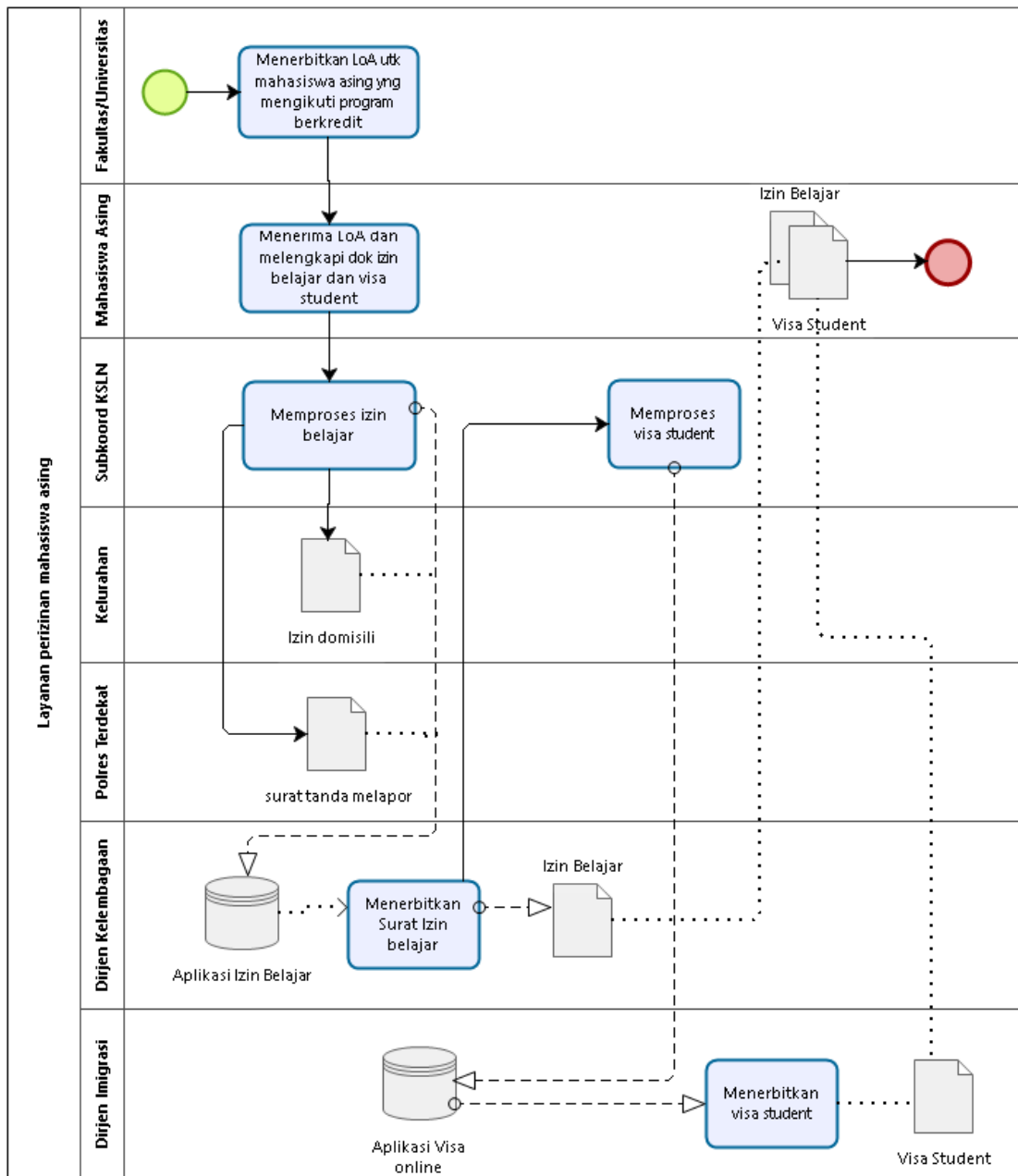

Level 5 Layanan Pengurusan KITAS

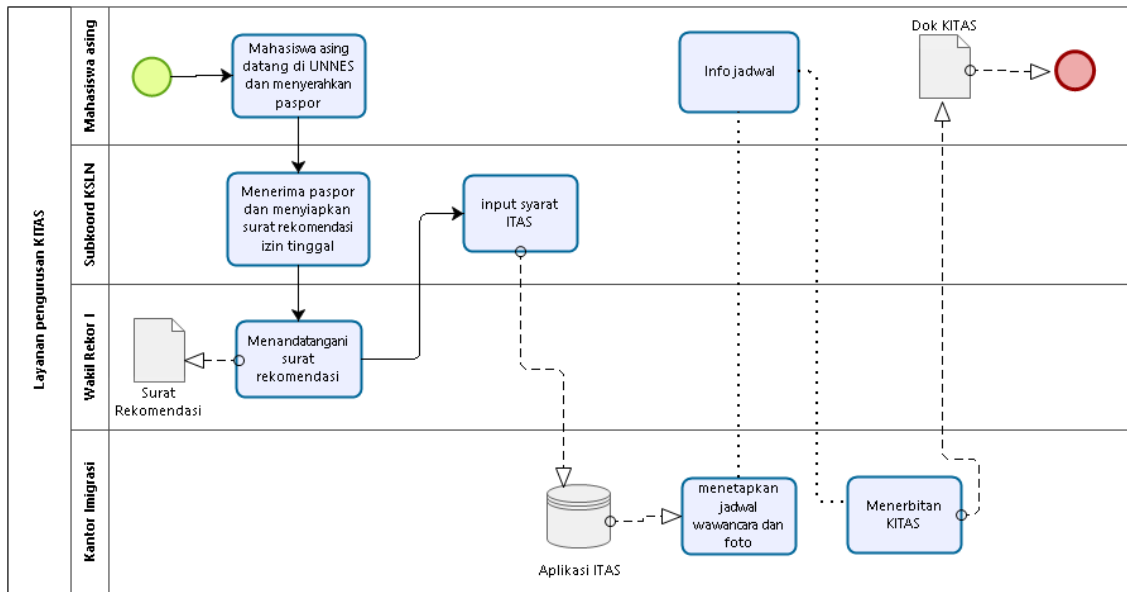

Powered by
bizagi
Modeler

Level 5 Layanan Pengajuan Izin Perjalanan Luar Negeri

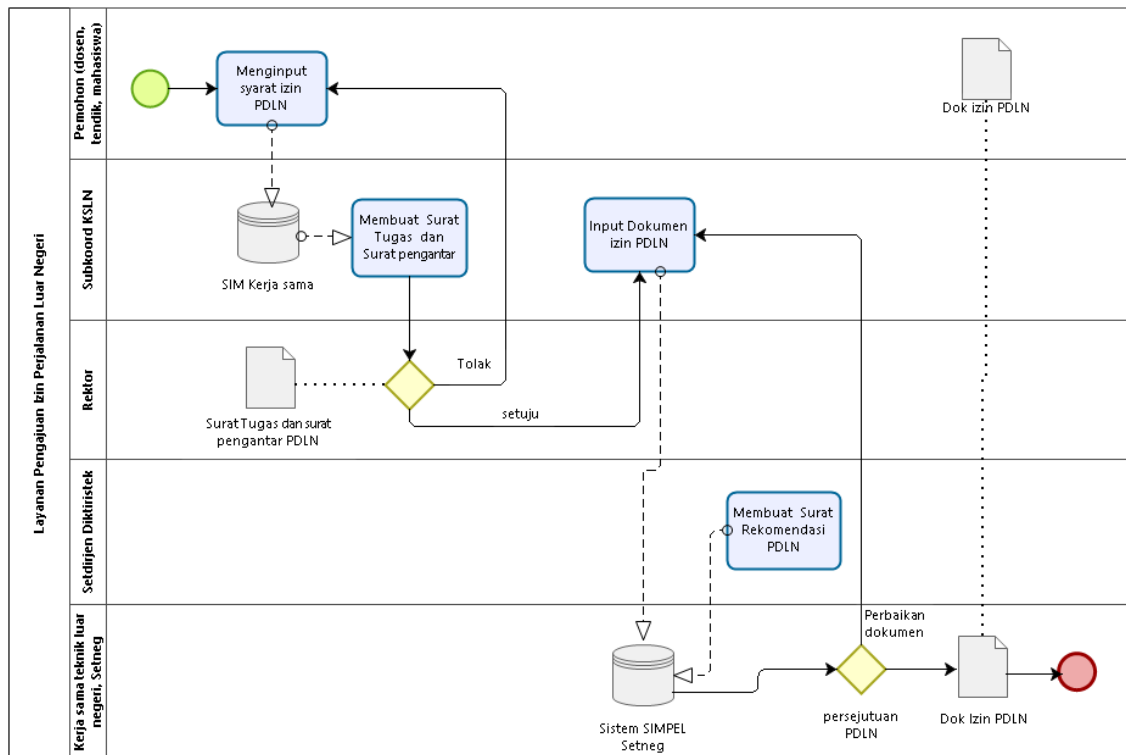

Level 5 Layanan Perizinan Dosen atau Peneliti Asing

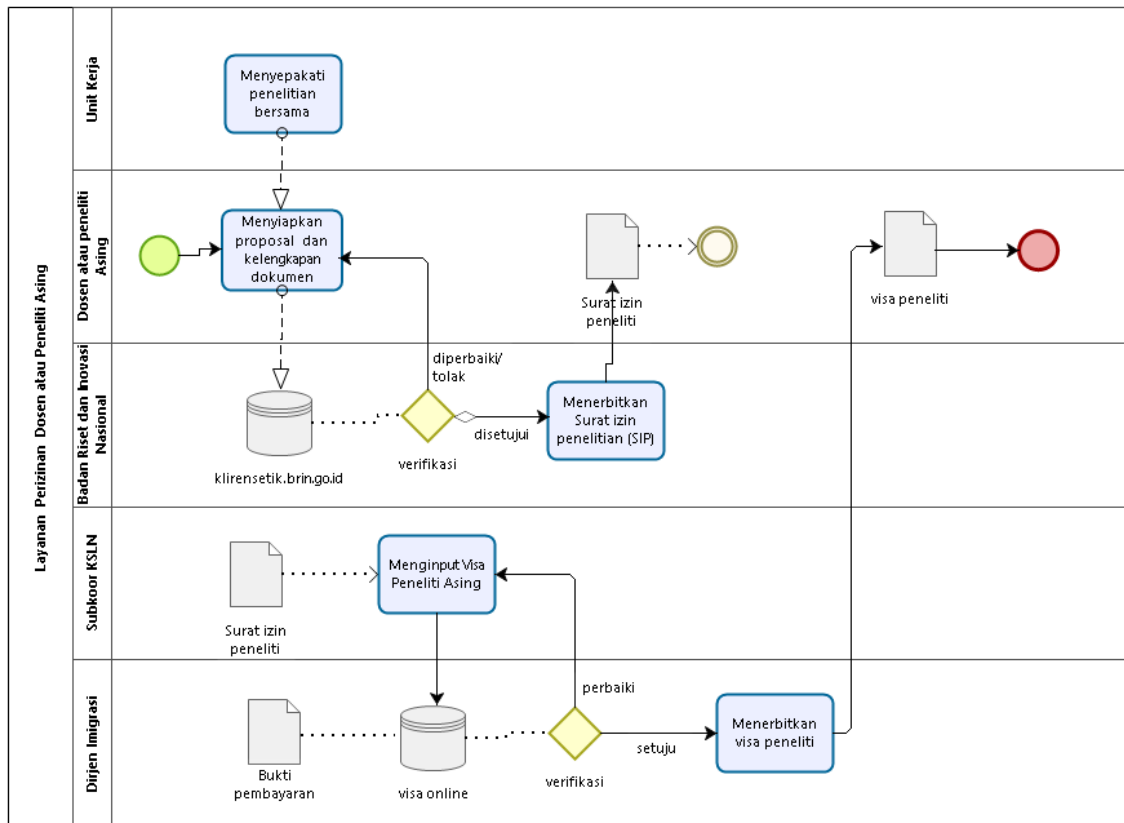

Level 5 Layanan Penerbitan Kode Dosen Tamu

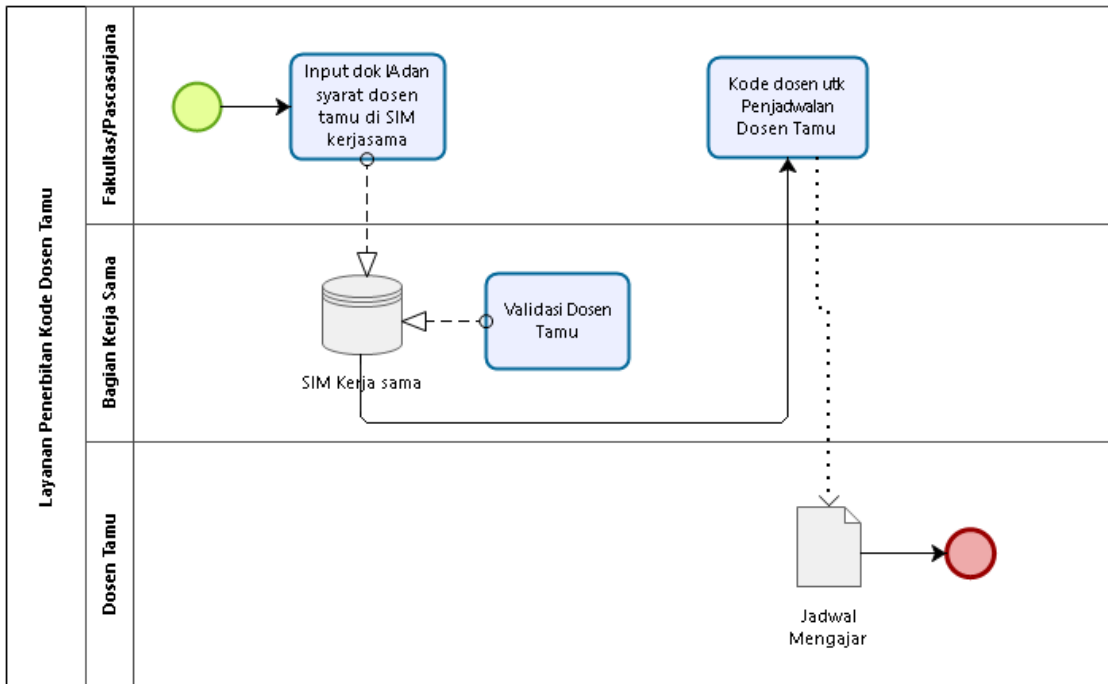

Level 1 Layanan Umum, Hukum dan Kepegawaian

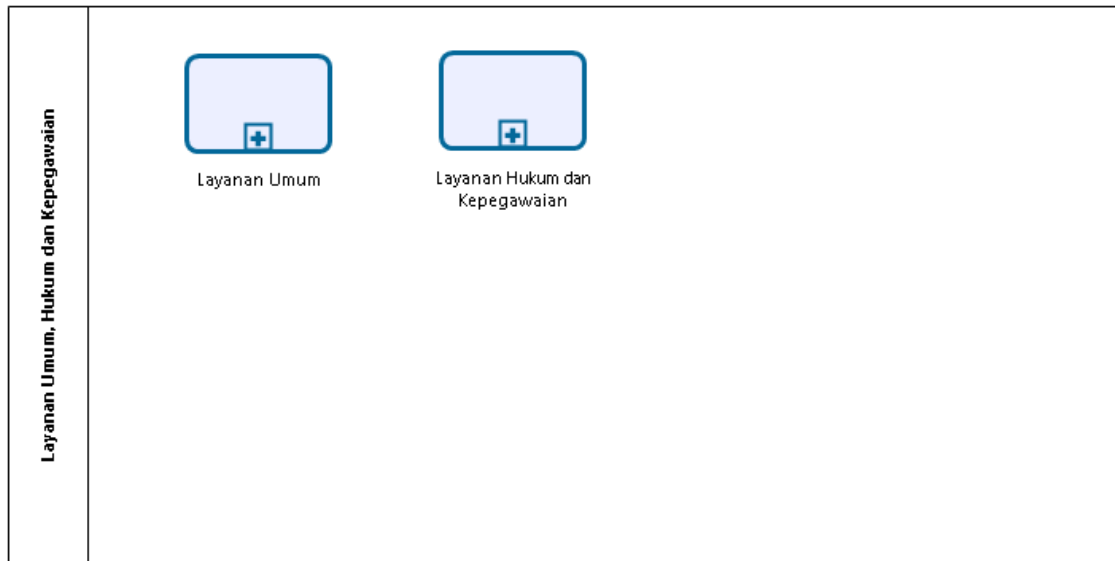

Powered by
bizagi
Modeler

Level 2 Layanan Umum

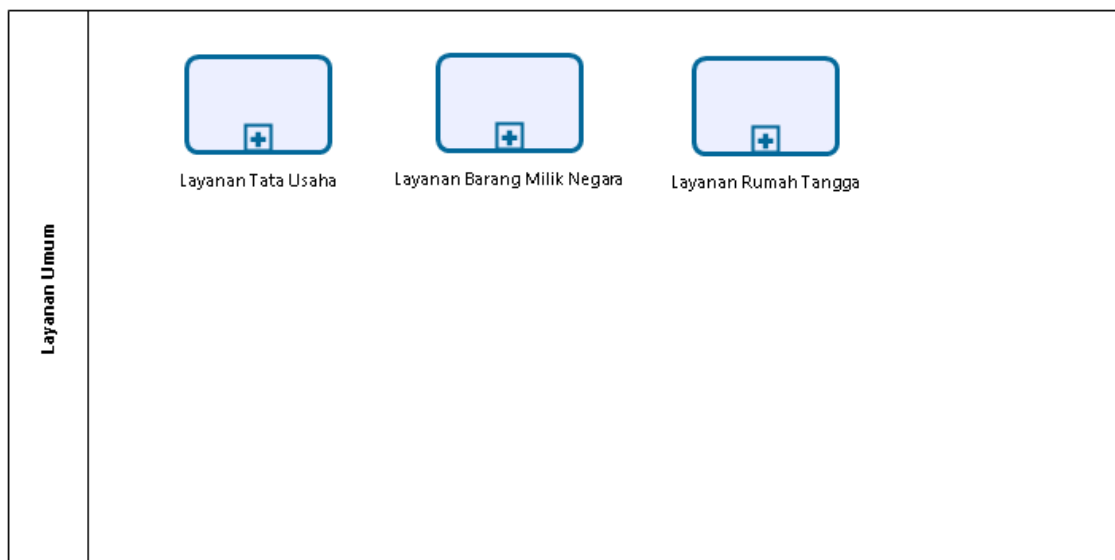

Powered by
bizagi
Modeler

Level 3 Layanan Tata Usaha

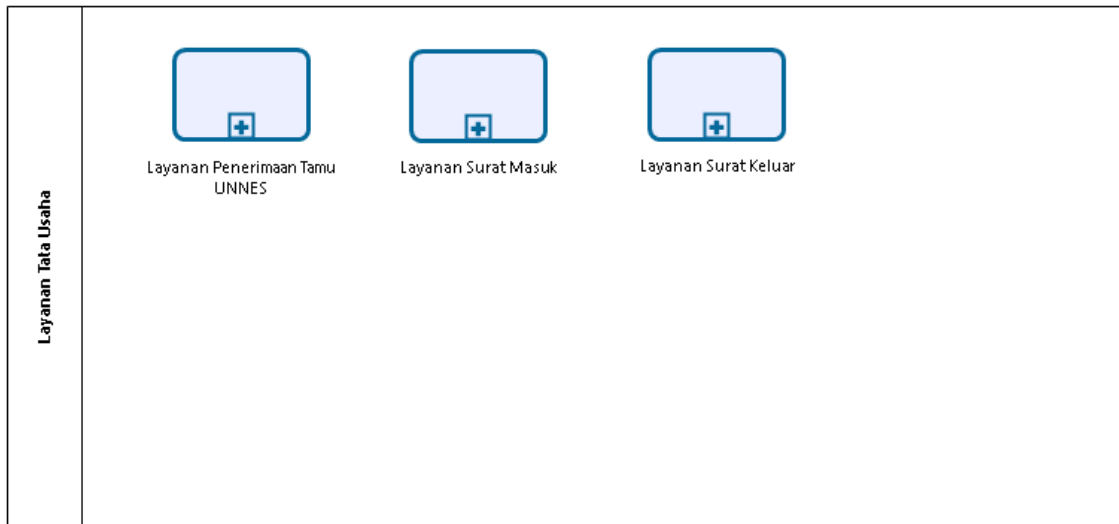

Level 4 Layanan Penerimaan Tamu UNNES

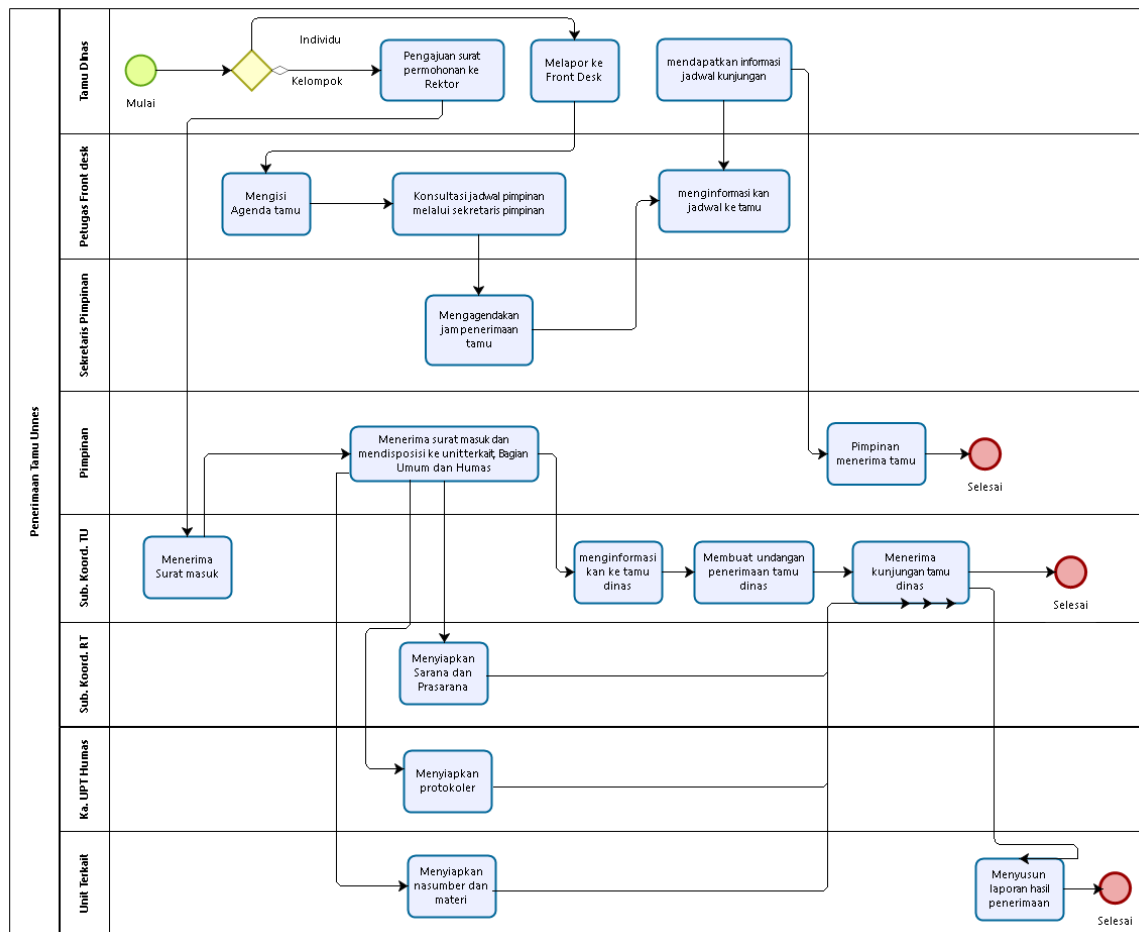

Level 4 Layanan Surat Masuk

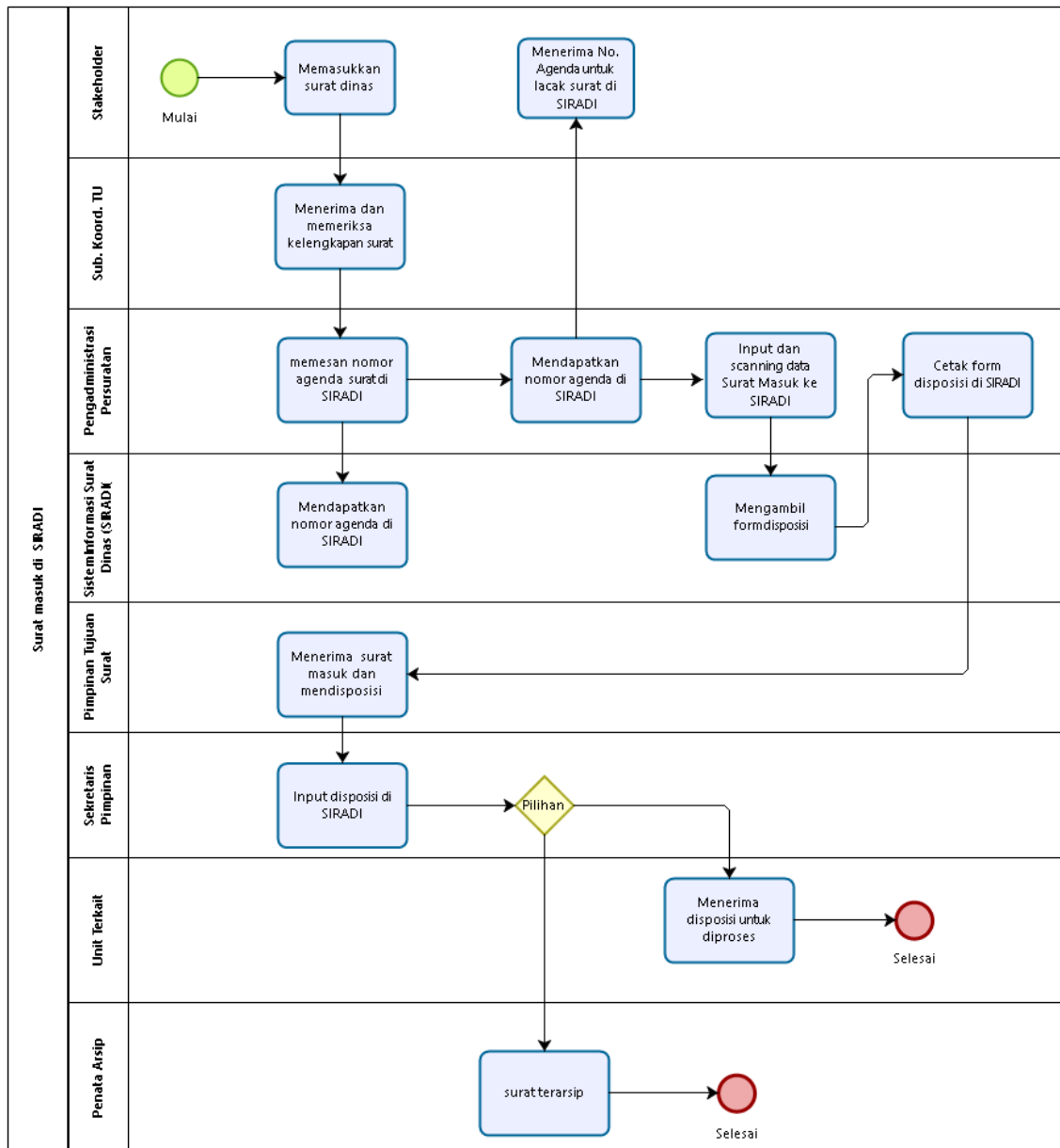

Level 4 Layanan Surat Keluar

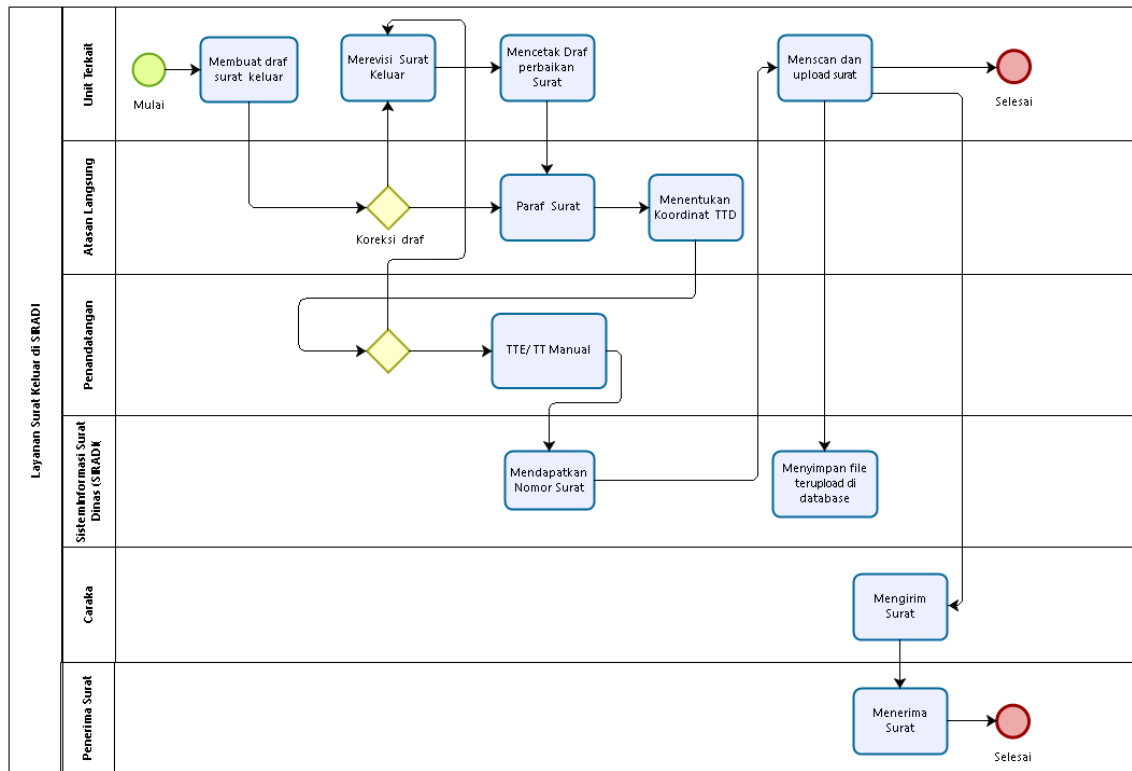

Powered by
bizagi
Modeler

Level 3 Layanan Barang Milik Negara

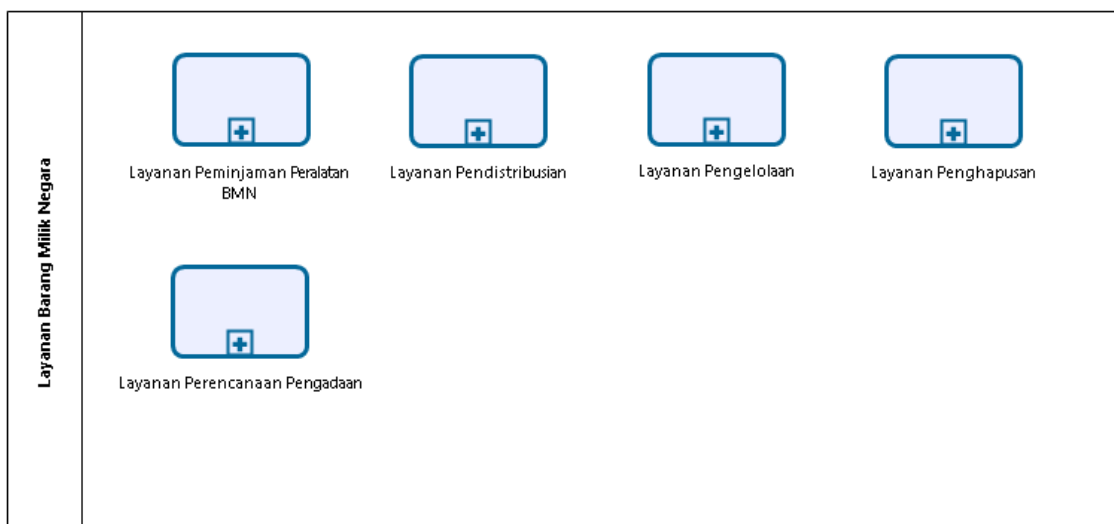

Powered by
bizagi
Modeler

Level 4 Layanan Peminjaman Peralatan BMN

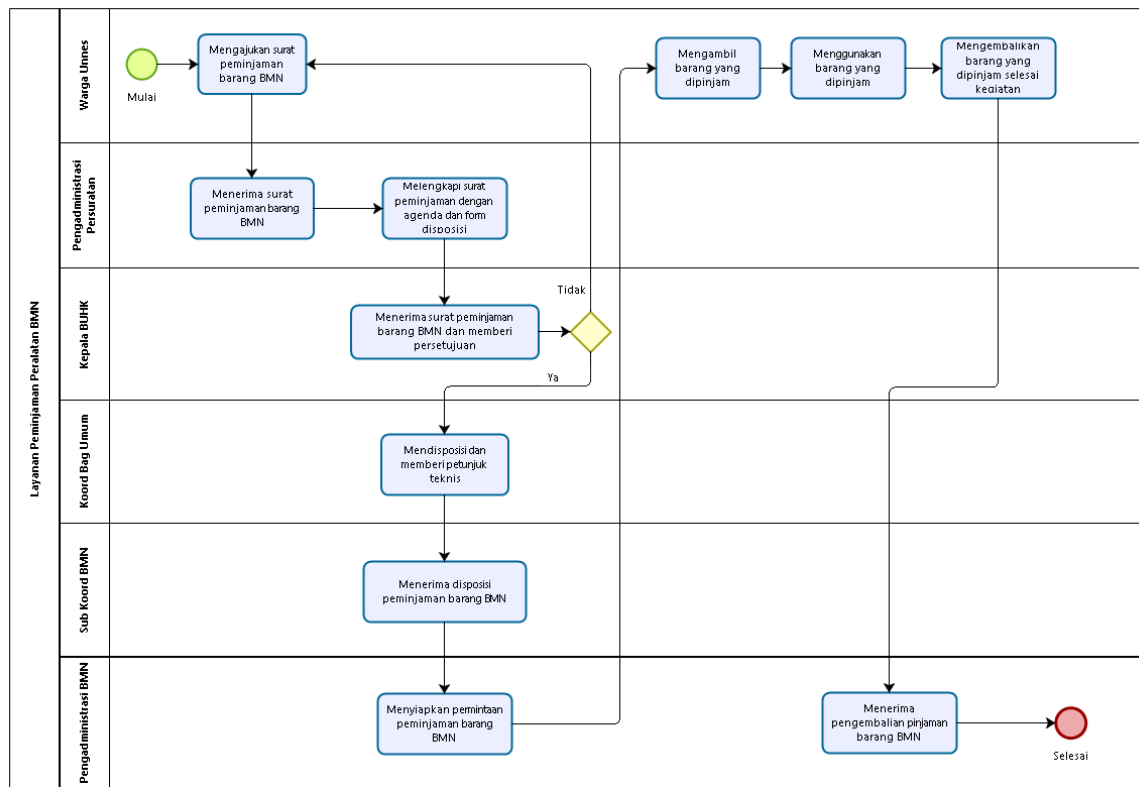

Level 4 Layanan Pendistribusian BMN

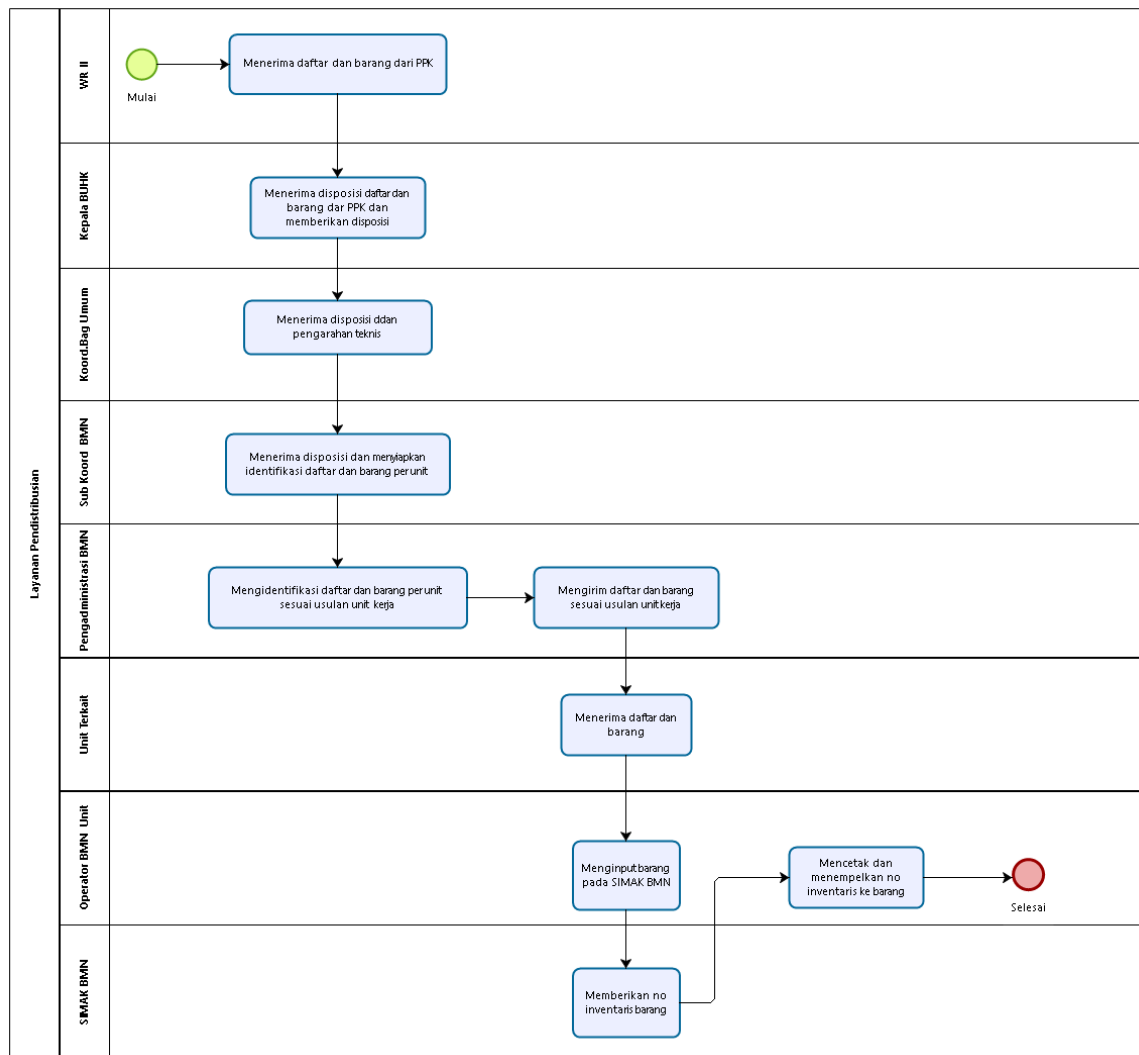

Level 4 Layanan Pengelolaan BMN

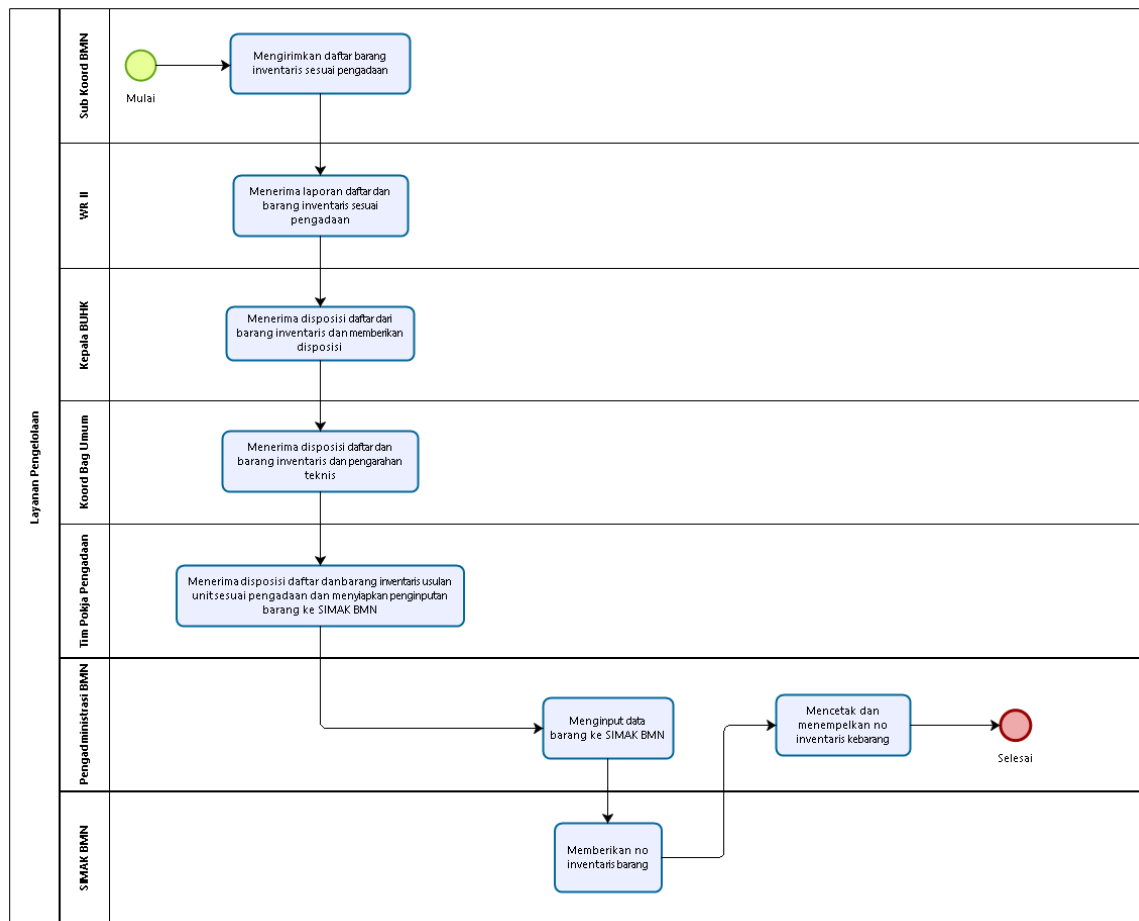

Level 4 Layanan Penghapusan BMN

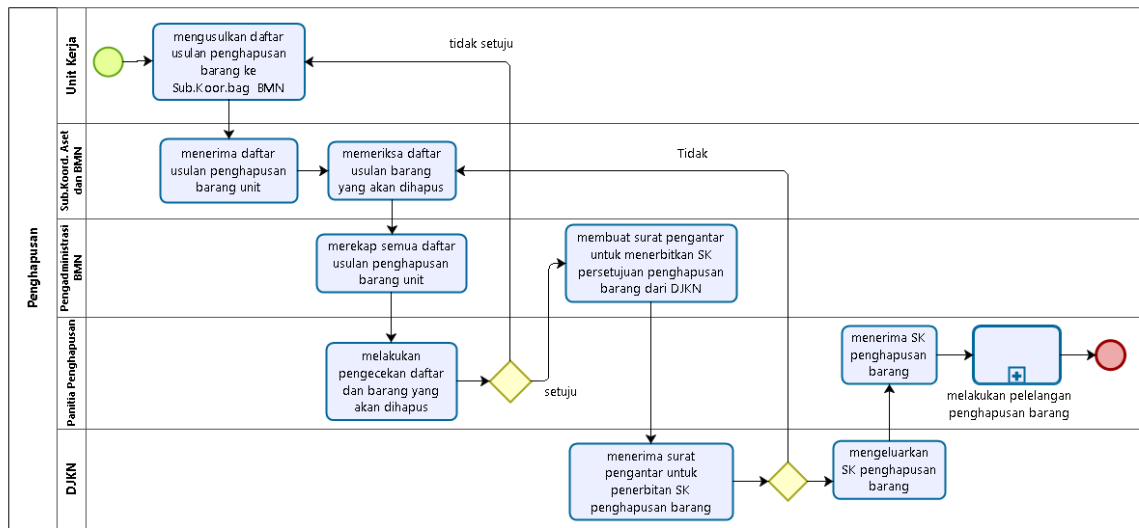

Level 4 Layanan Perencanaan Pengadaan BMN

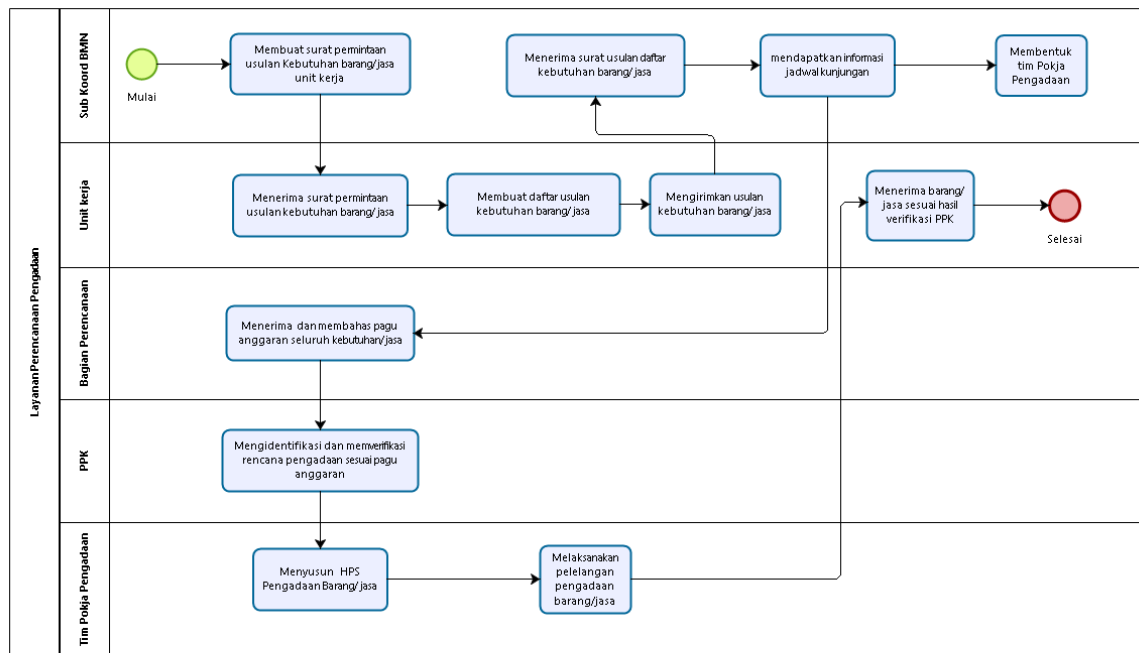

Powered by
bizagi
Modeler

Level 3 Layanan Rumah Tangga



Powered by
bizagi
Modeler

Level 4 Layanan Pemeliharaan Gedung dan Sarana Prasarana

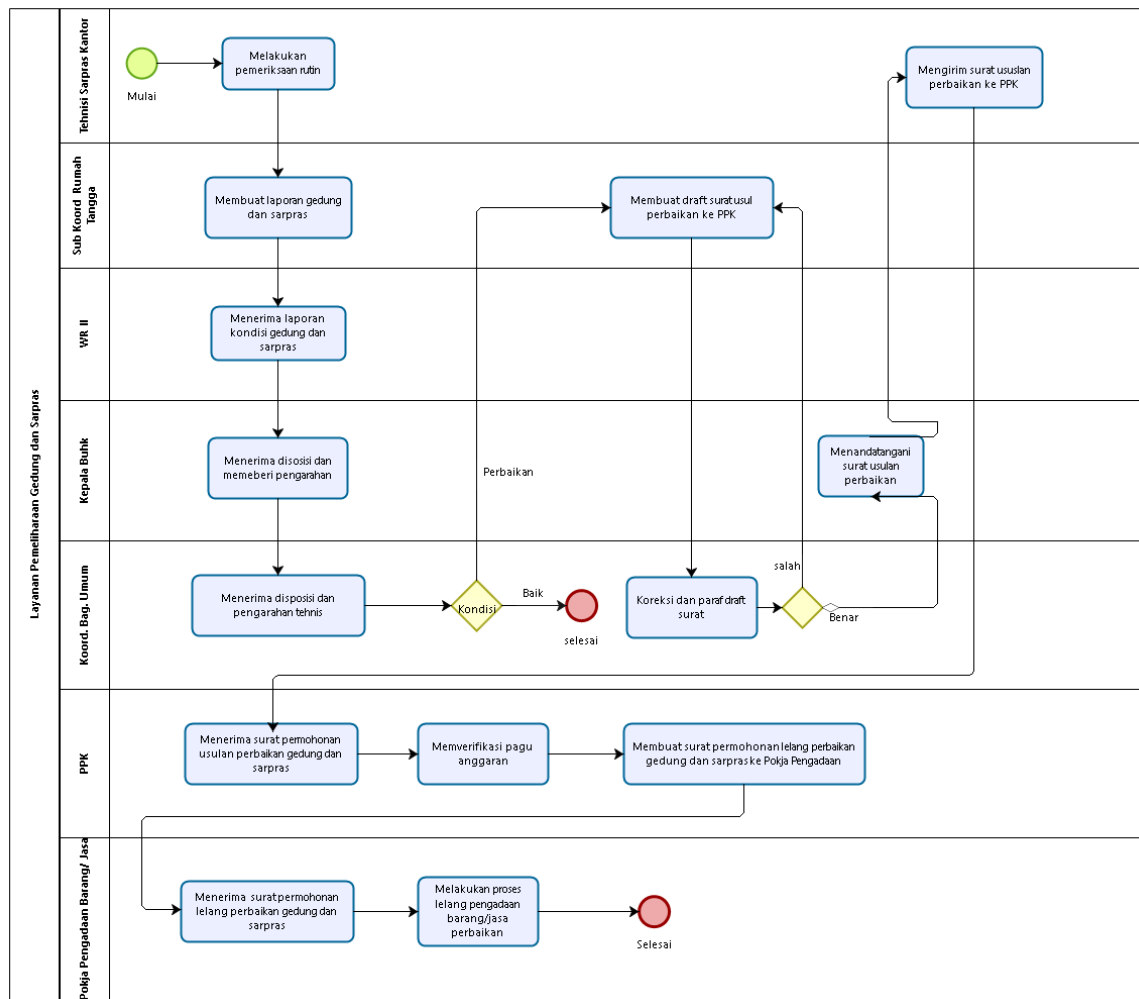

Level 4 Layanan Pemeliharaan Kendaraan Dinas

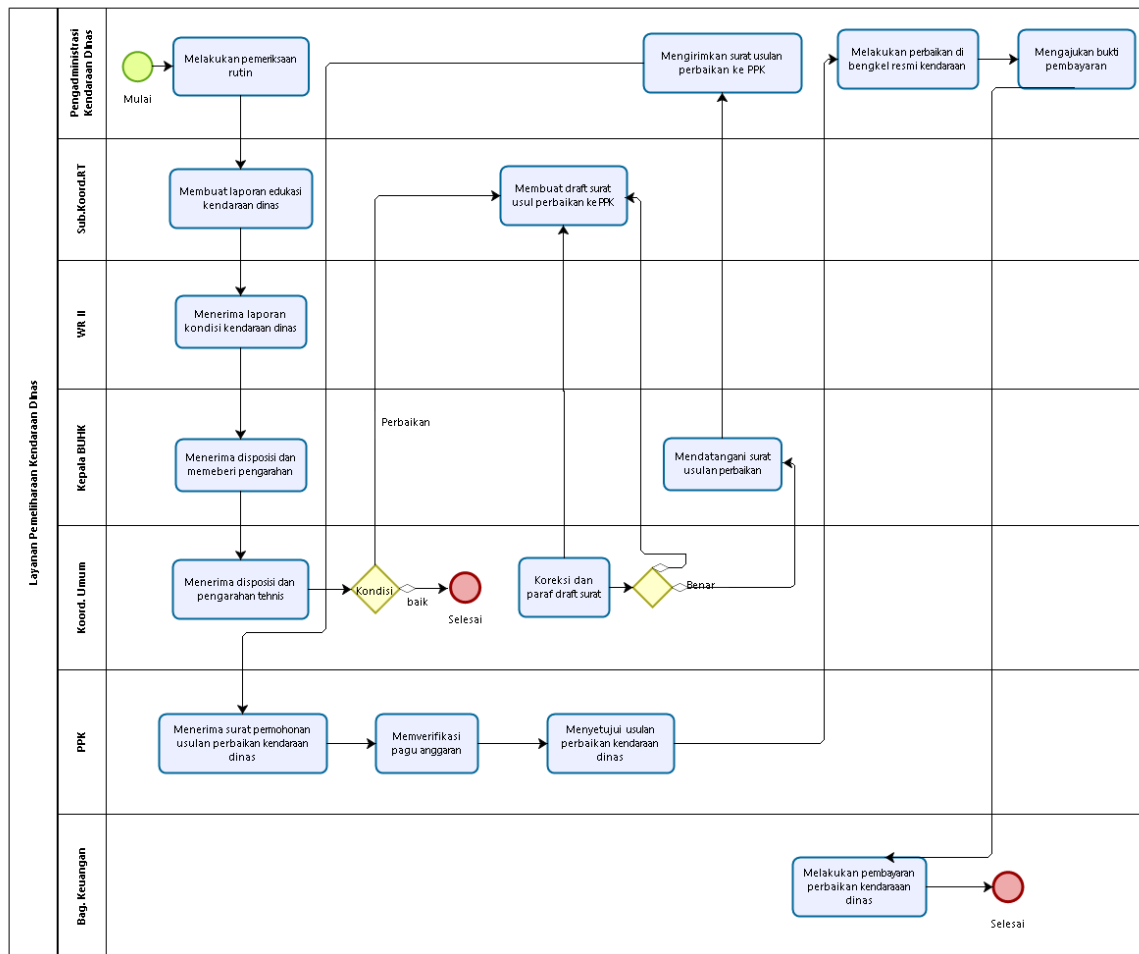

Level 4 Layanan Peminjaman Peralatan Rumah Tangga

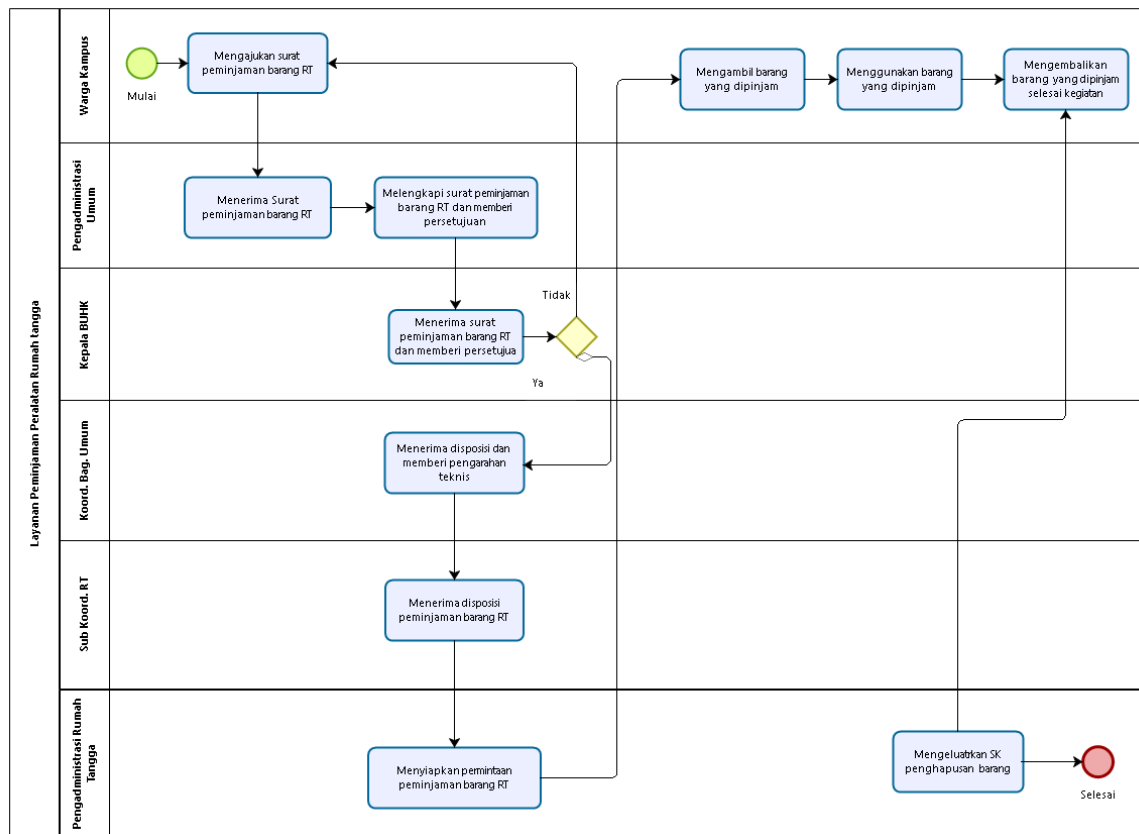

Level 4 Layanan Peminjaman Kendaraan Dinas

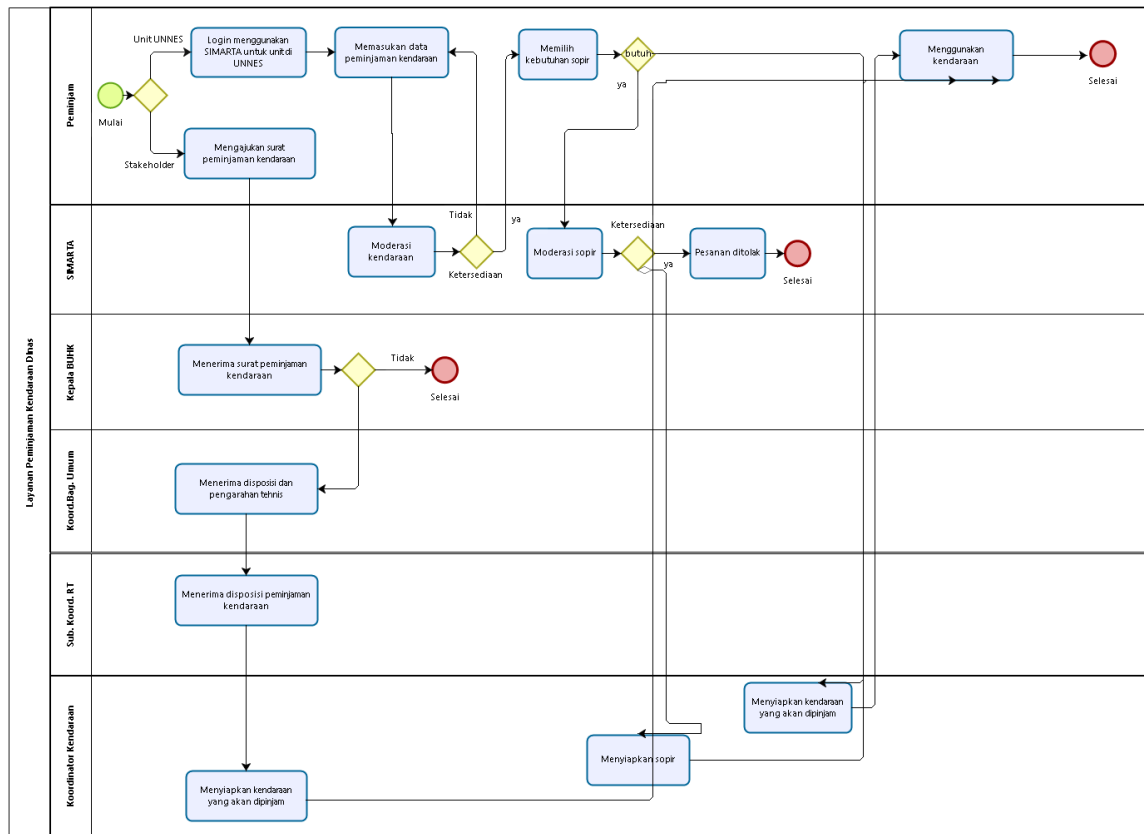

Level 4 Layanan Peminjaman Ruang

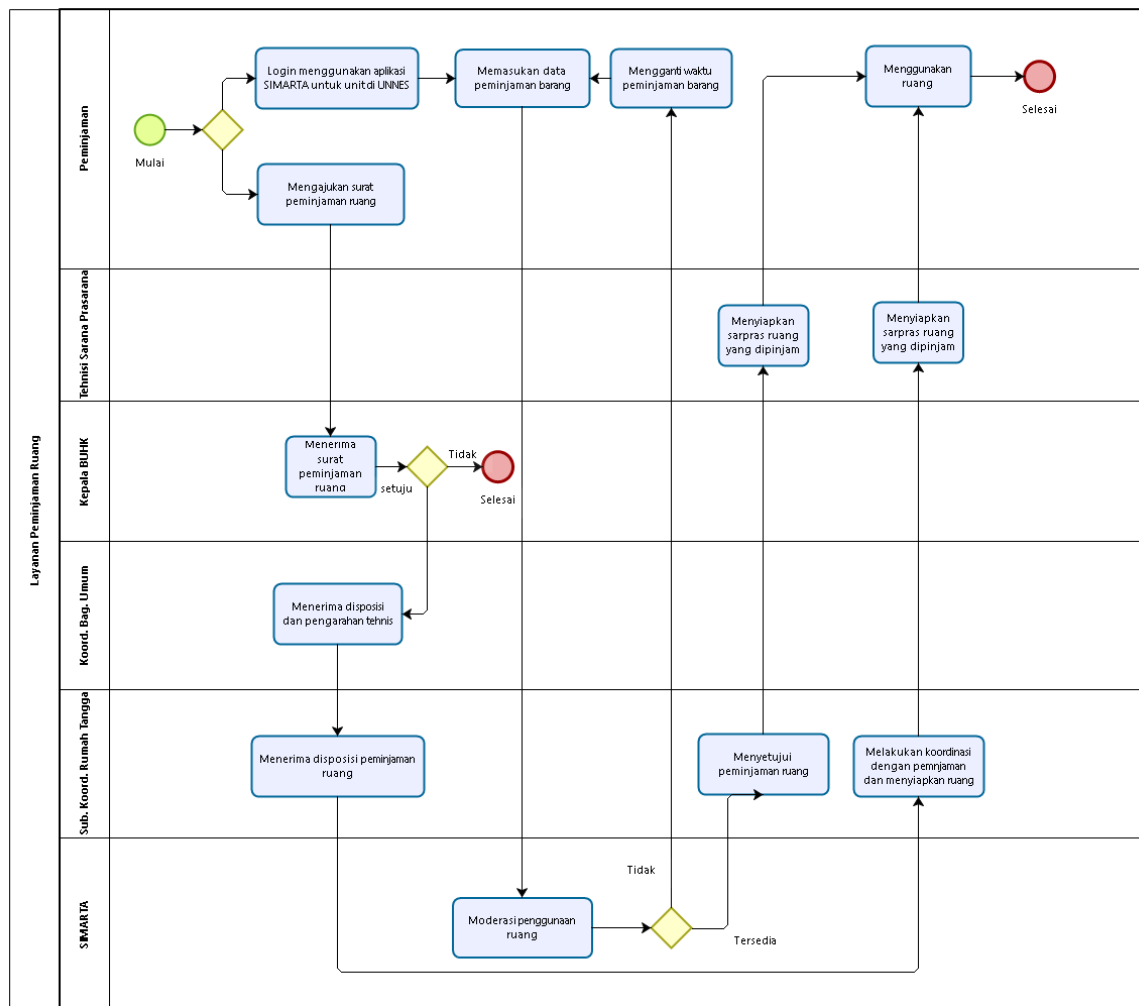

Level 4 Layanan Pemeliharaan Halaman dan Taman

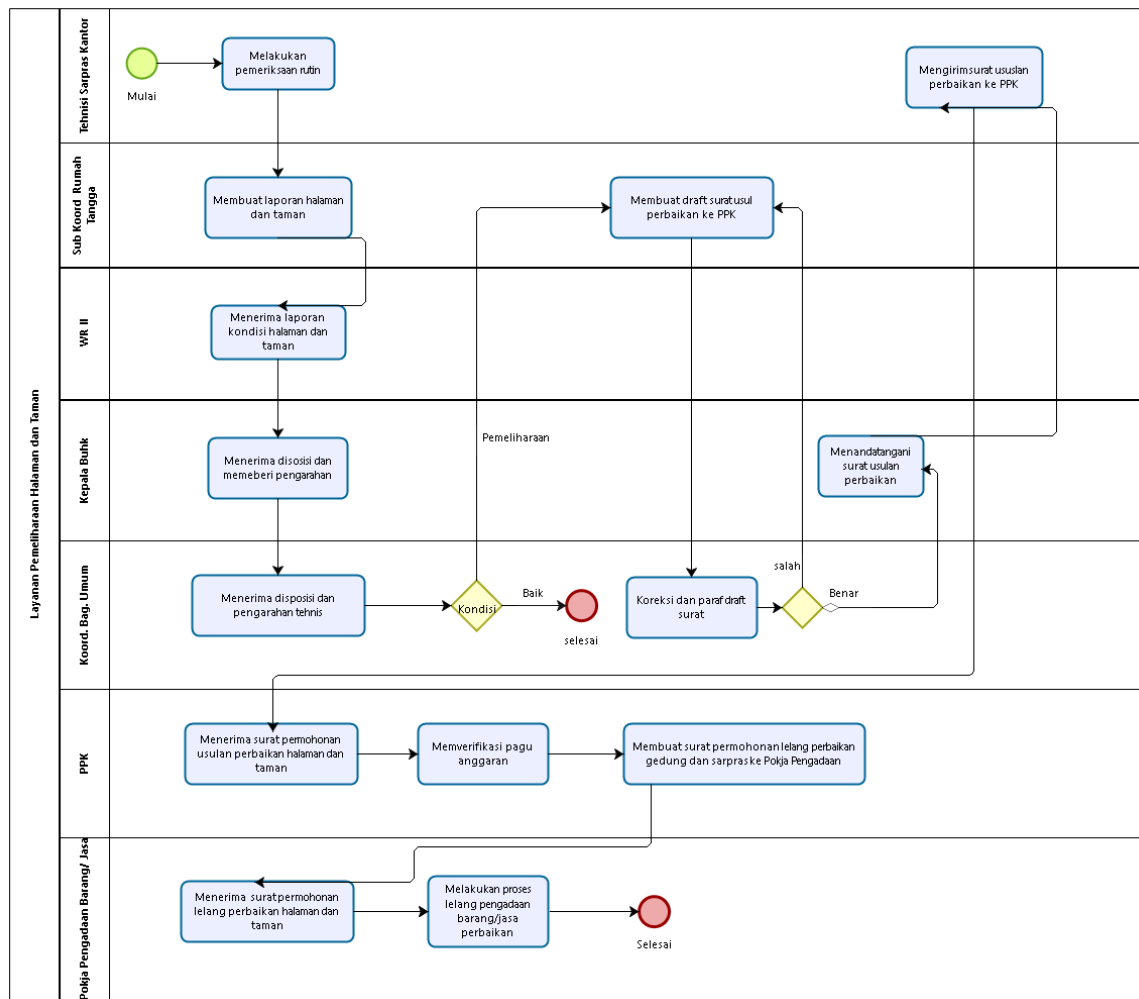

Level 2 Layanan Hukum dan Kepegawaian

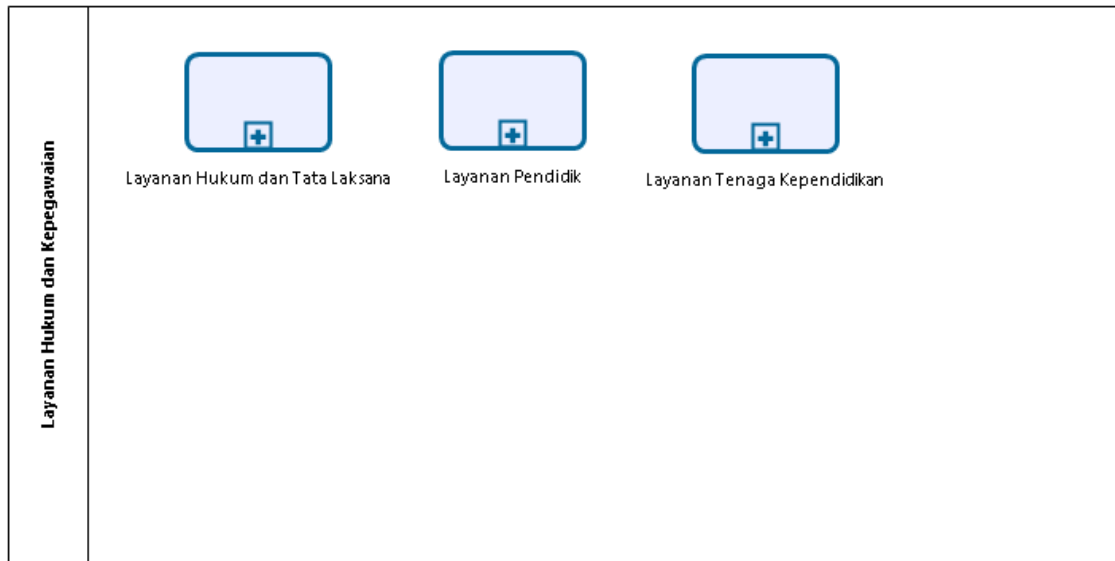

Powered by
bizagi
Modeler

Level 3 Layanan Hukum dan Tata Laksana

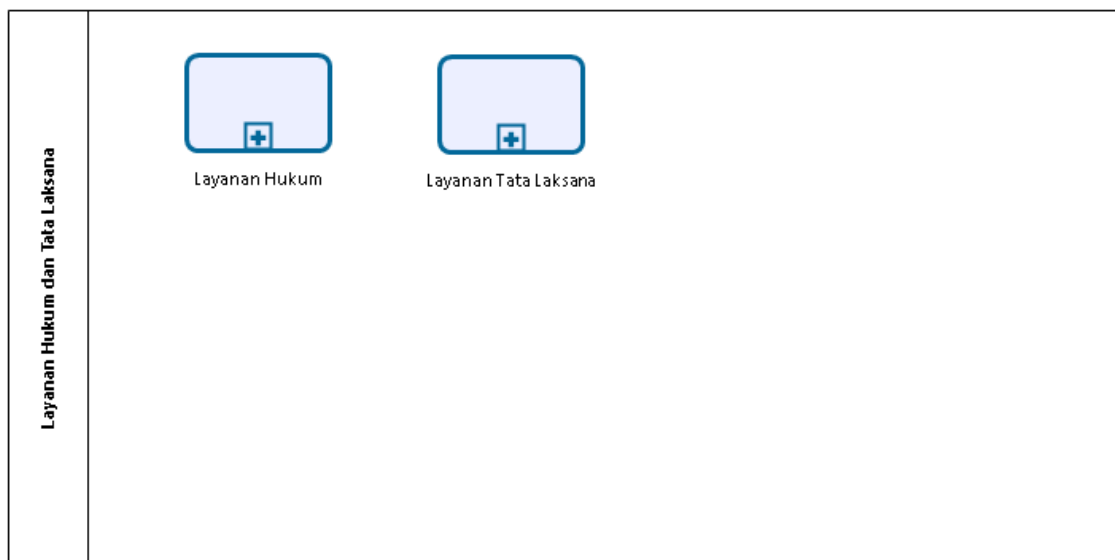

Powered by
bizagi
Modeler

Level 4 Layanan Hukum

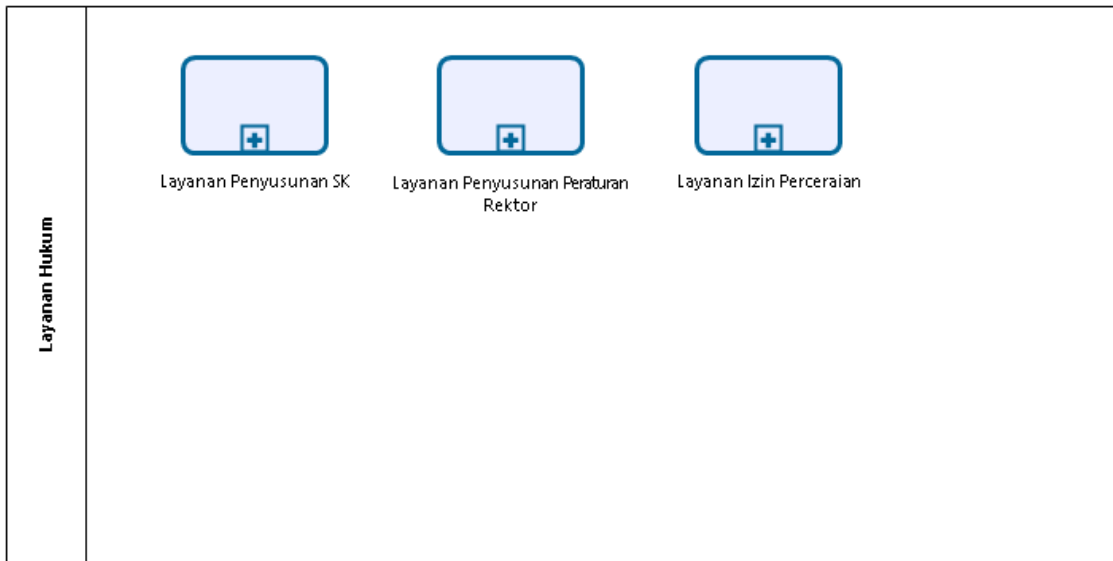

Level 5 Layanan Penyusunan SK

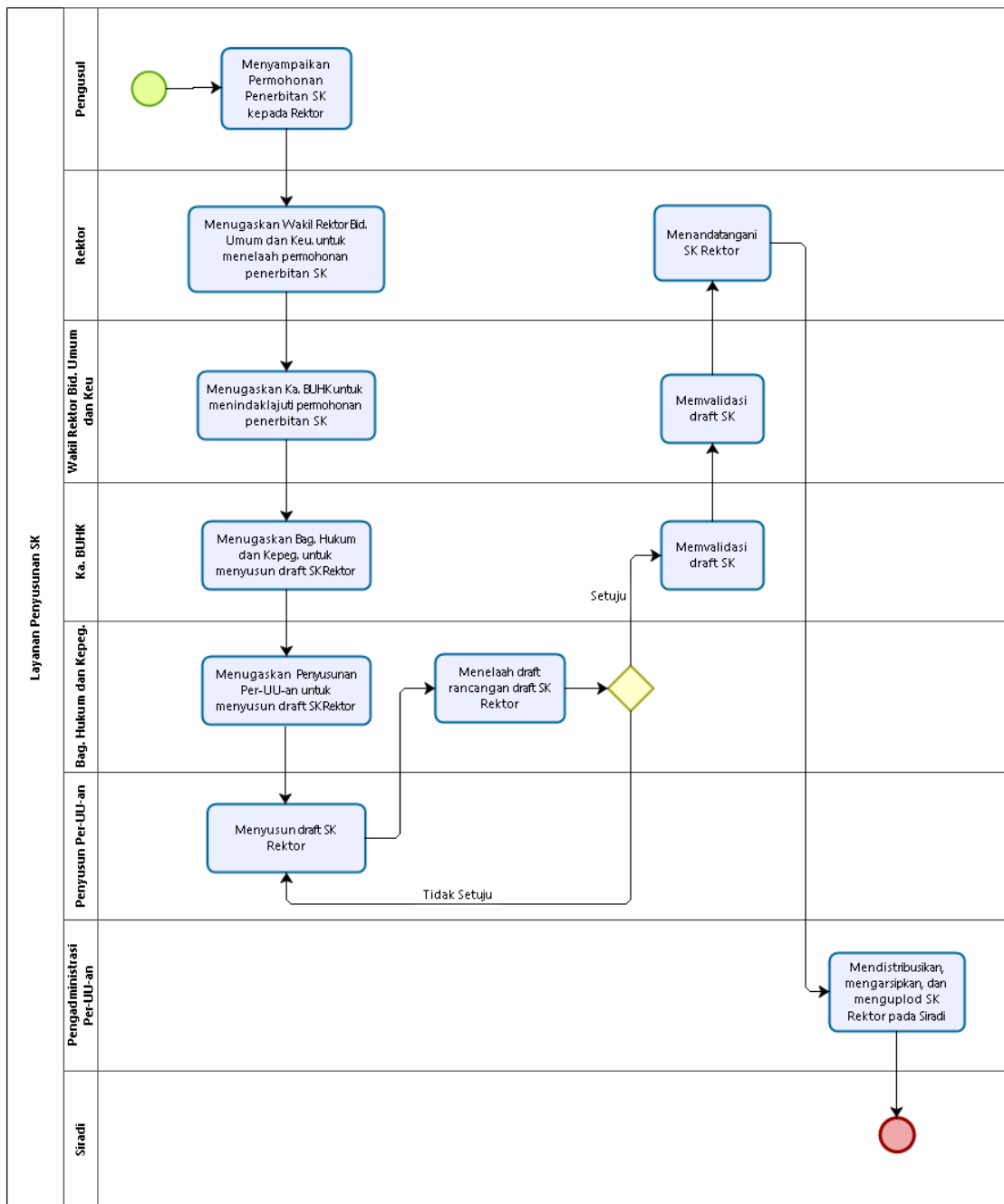

Level 5 Layanan Penyusunan Peraturan Rektor

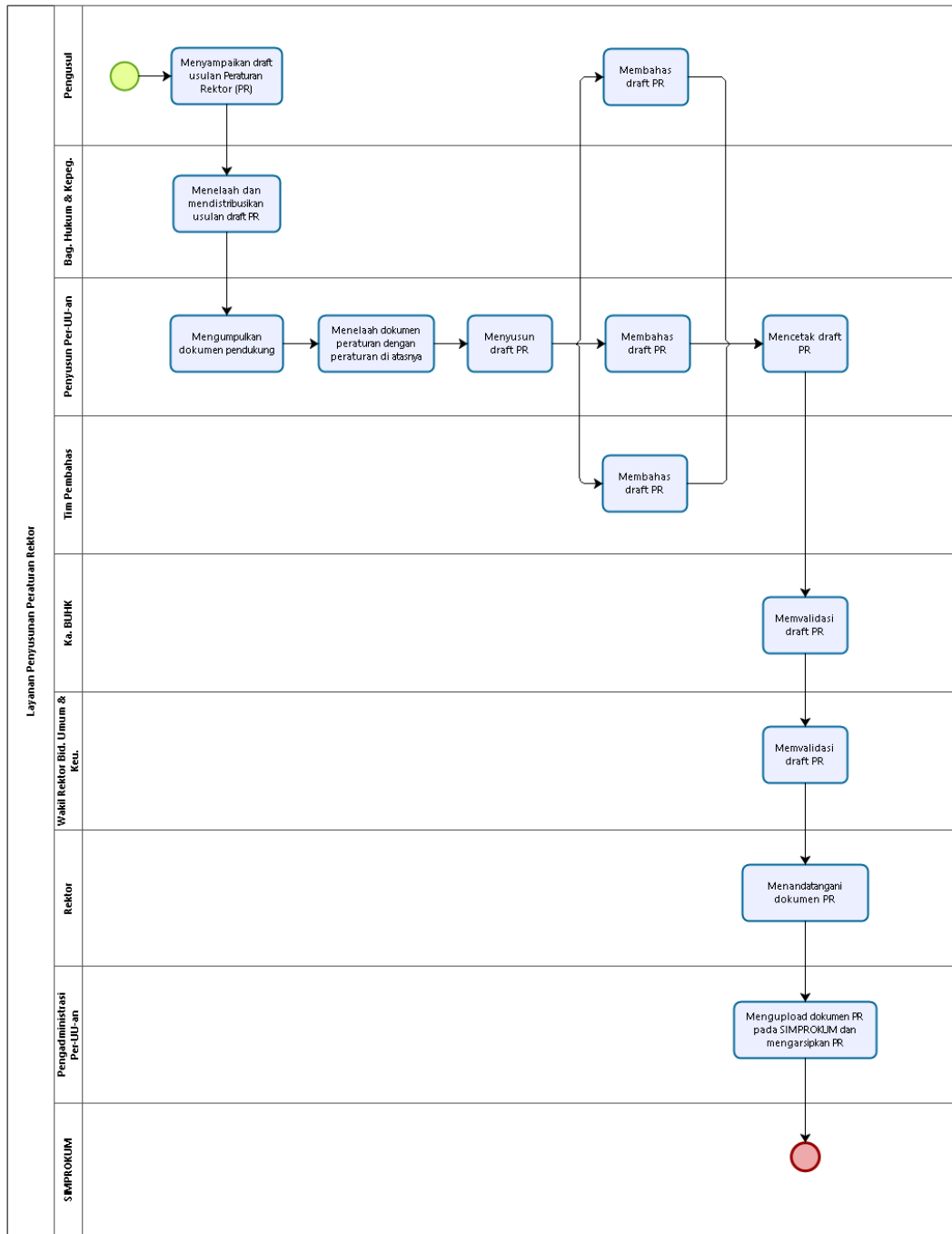

Level 5 Layanan Izin Perceraian

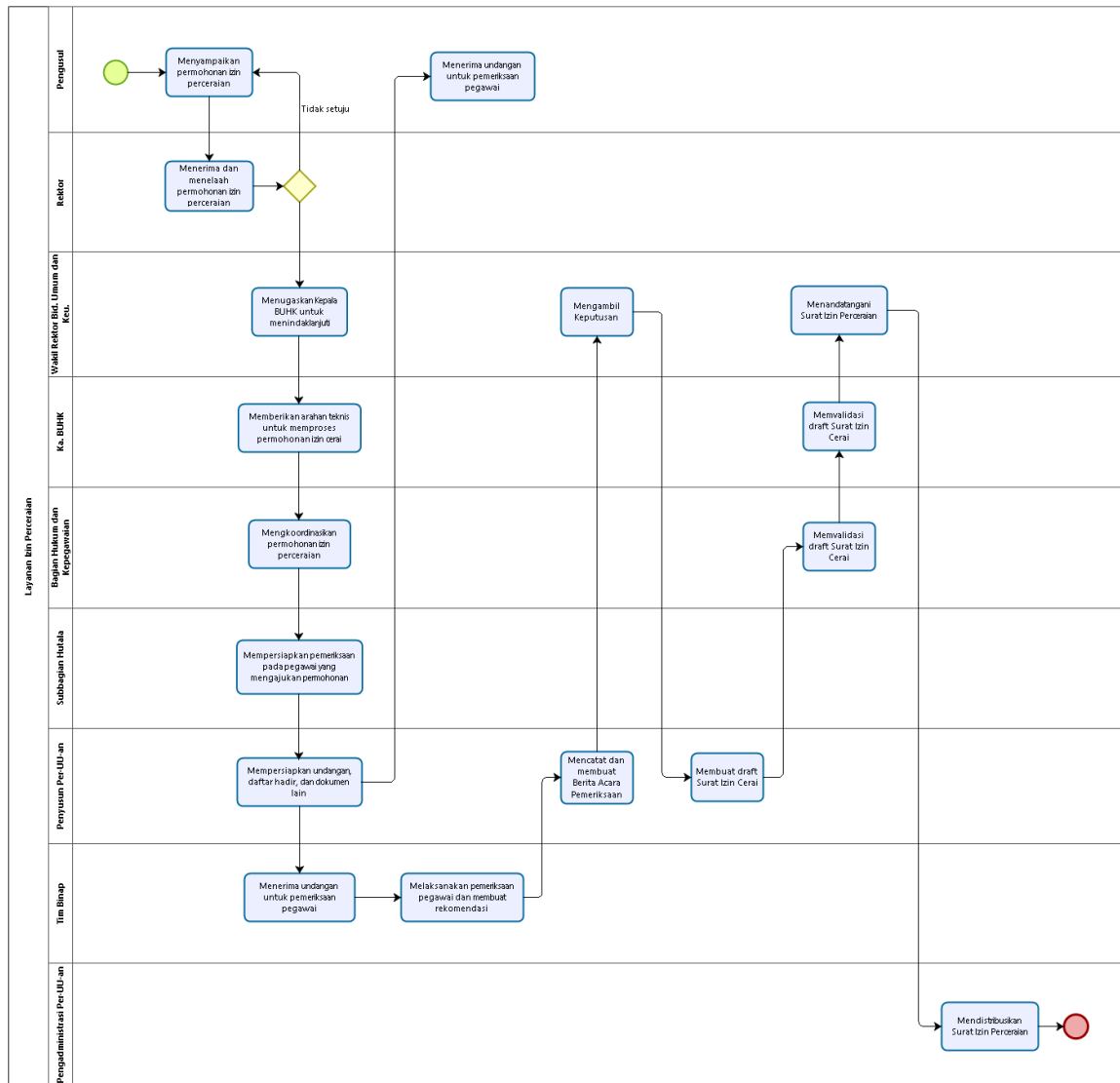

Level 4 Layanan Tata Laksana

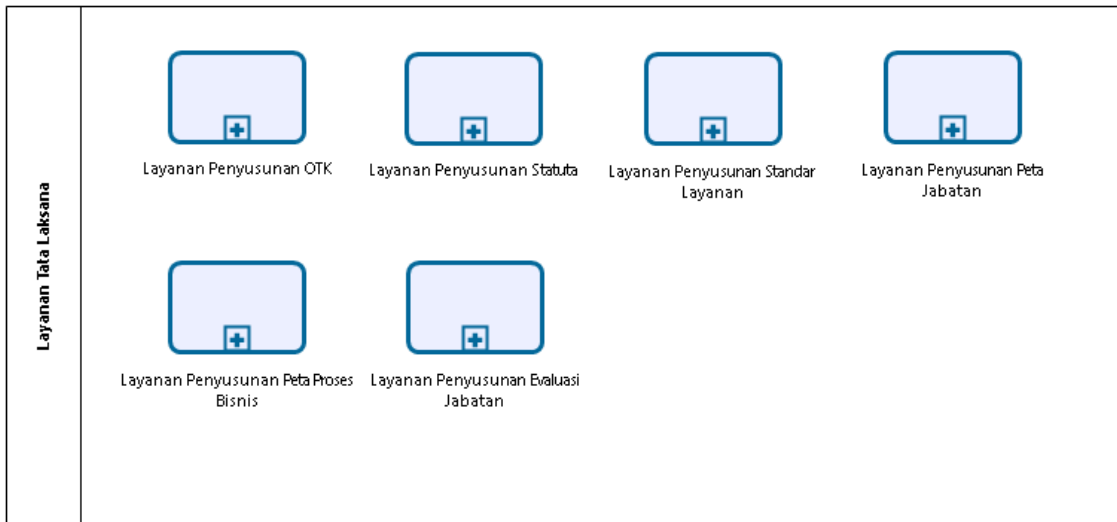

Powered by
bizagi
Modeler

Level 5 Layanan Penyusunan OTK

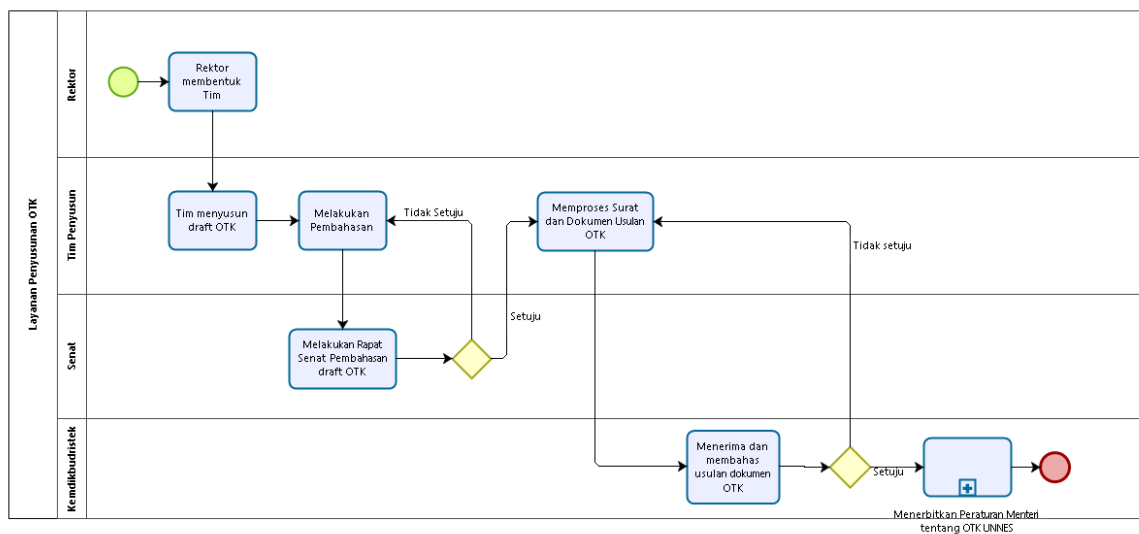

Powered by
bizagi
Modeler

Level 5 Layanan Penyusunan Statuta

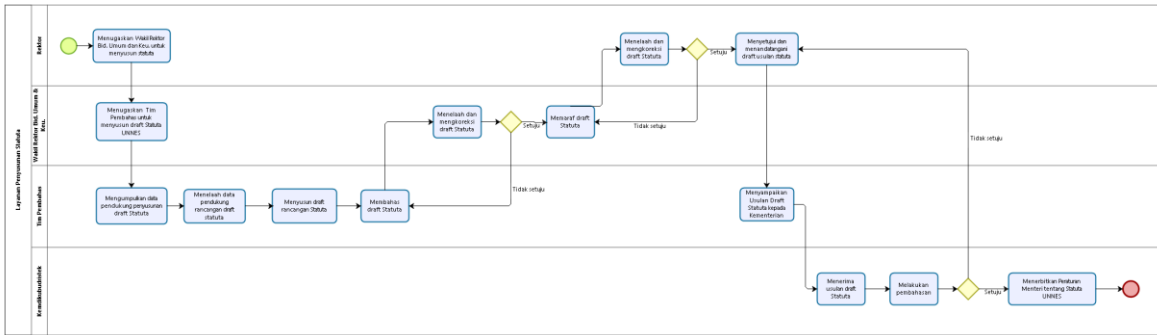

Level 5 Layanan Penyusunan Standar Layanan

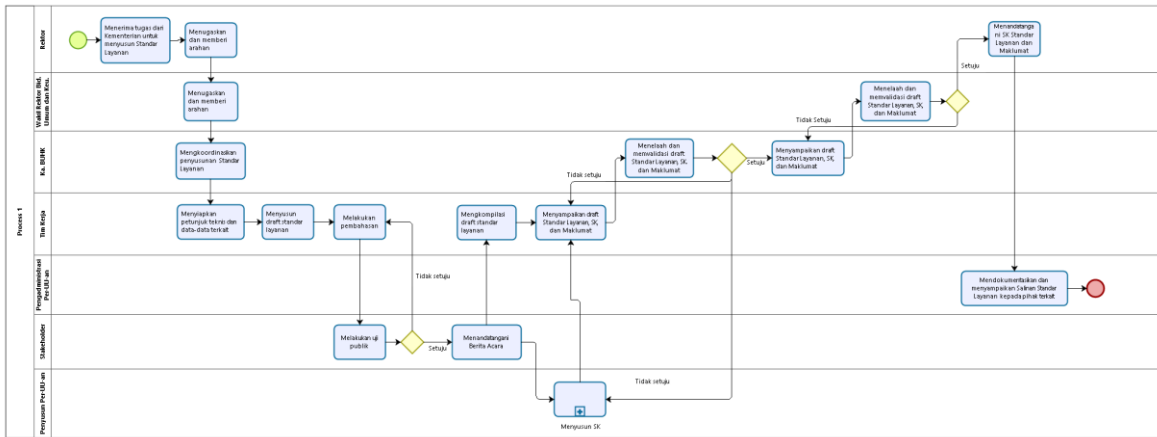

Level 5 Layanan Penyusunan Peta Jabatan

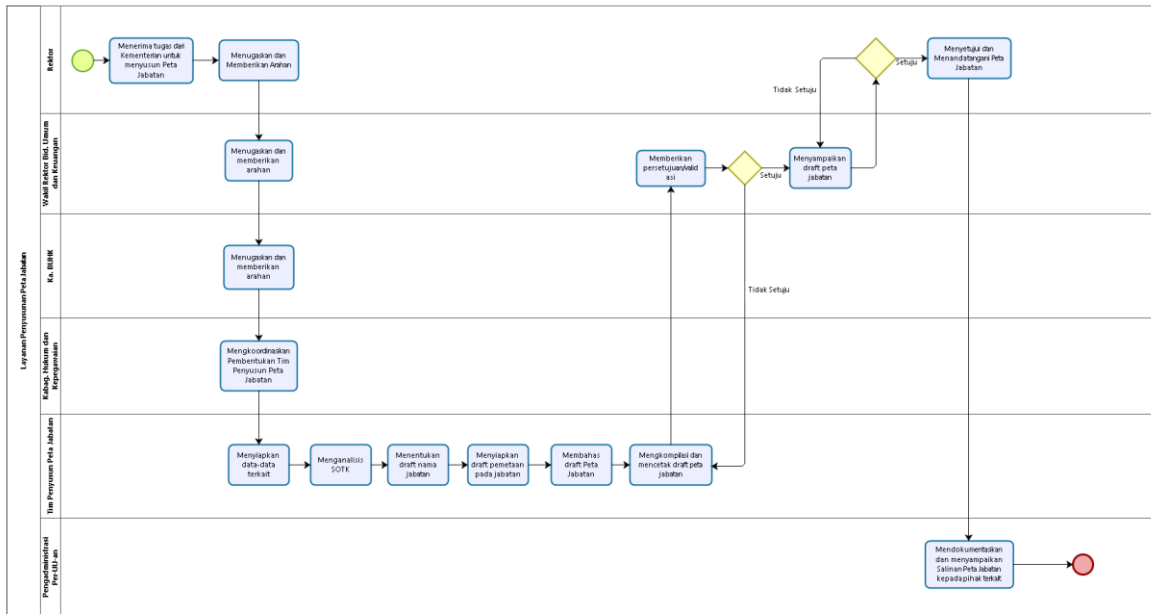

Presented by
bizagi
Model

Level 5 Layanan Penyusunan Peta Proses Bisnis

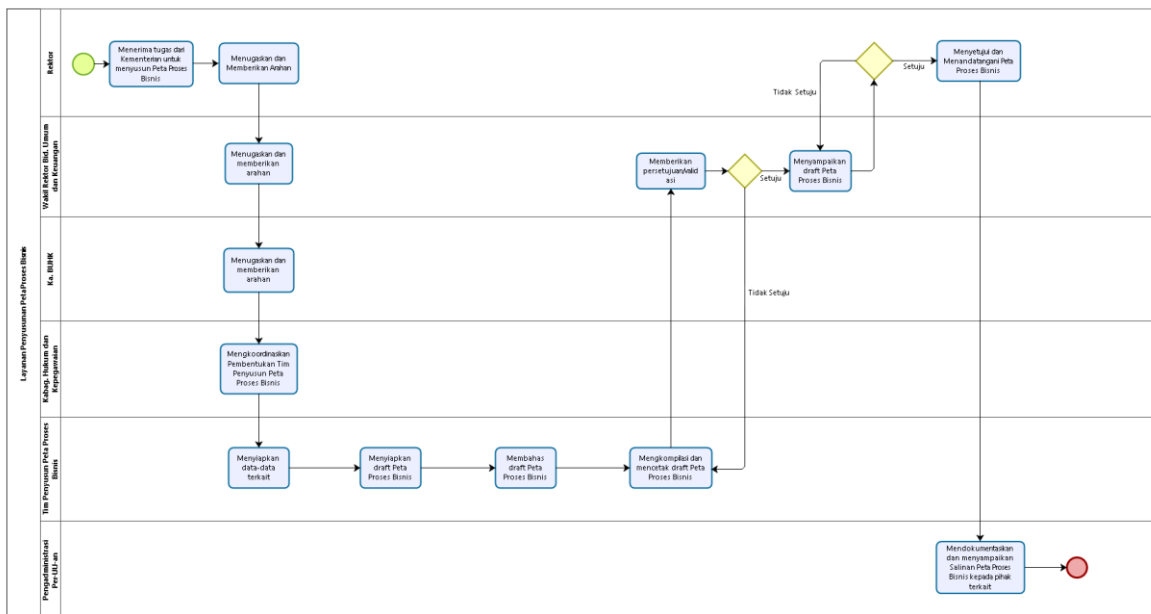

Presented by
bizagi
Model

Level 5 Layanan Penyusunan Evaluasi Jabatan

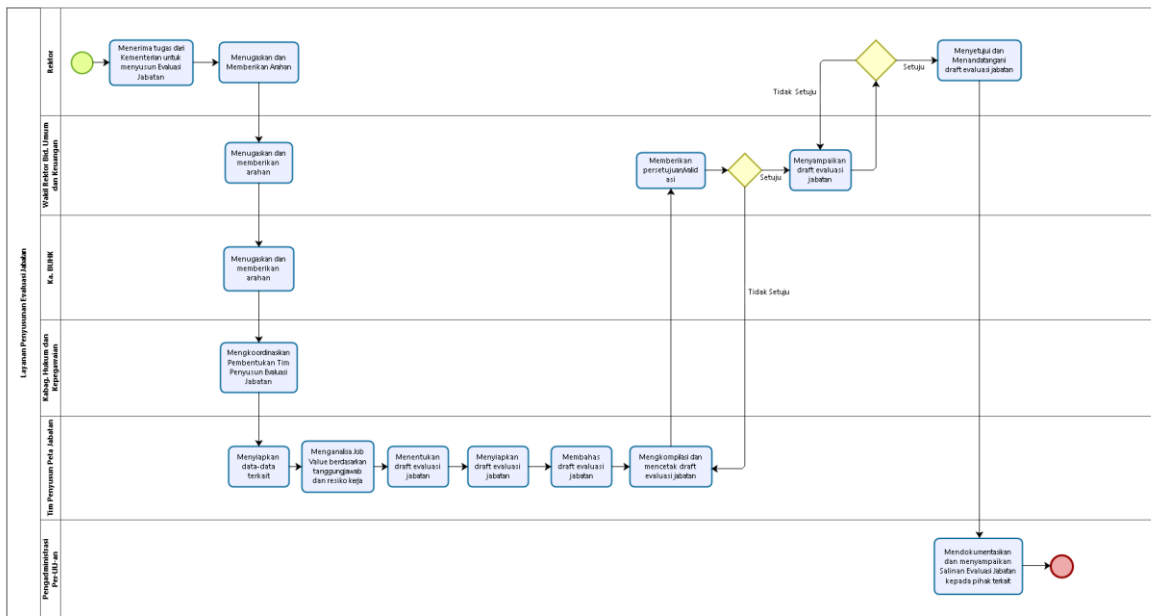

Level 3 Layanan Pendidik

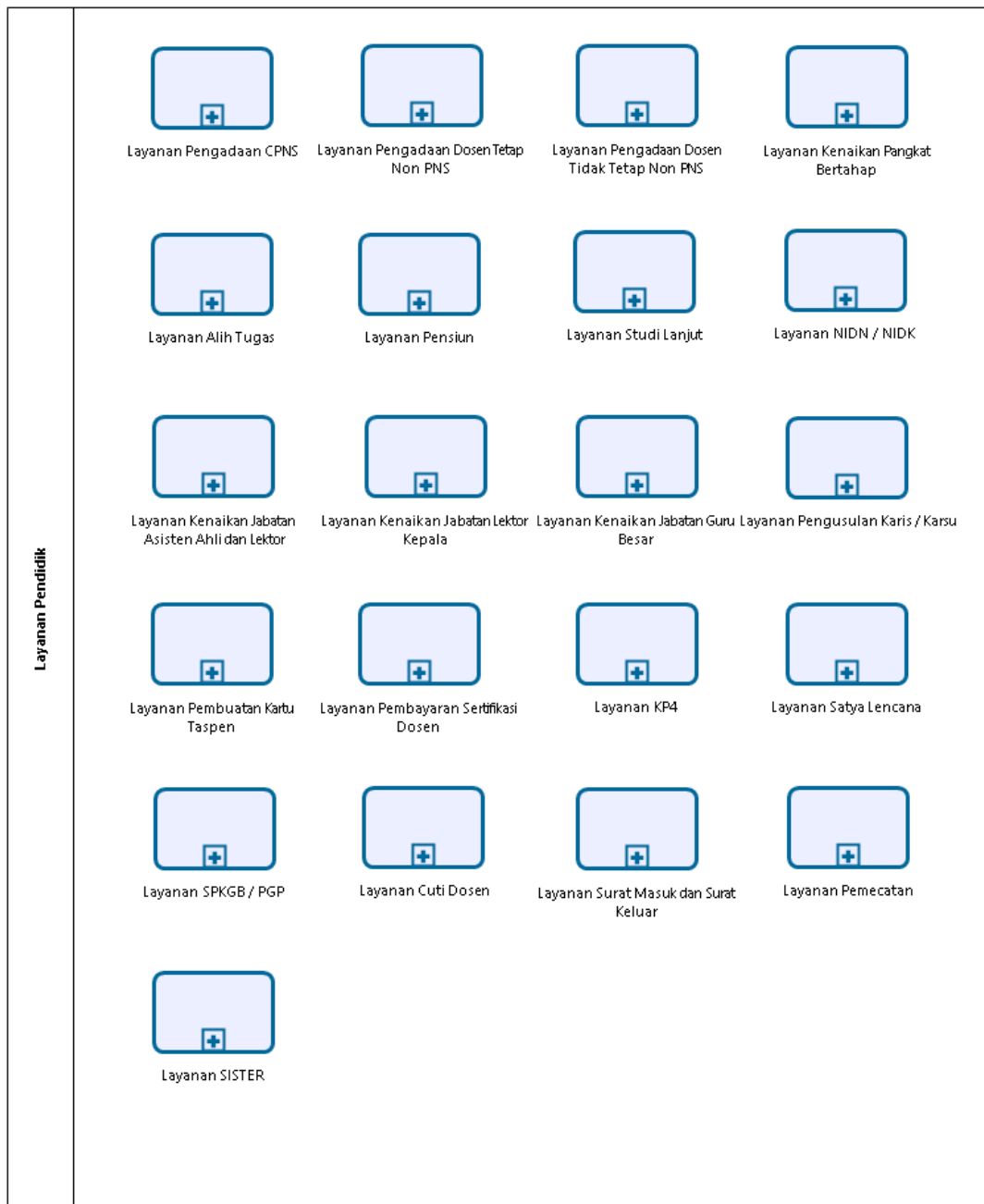

Level 4 Layanan Pengadaan CPNS

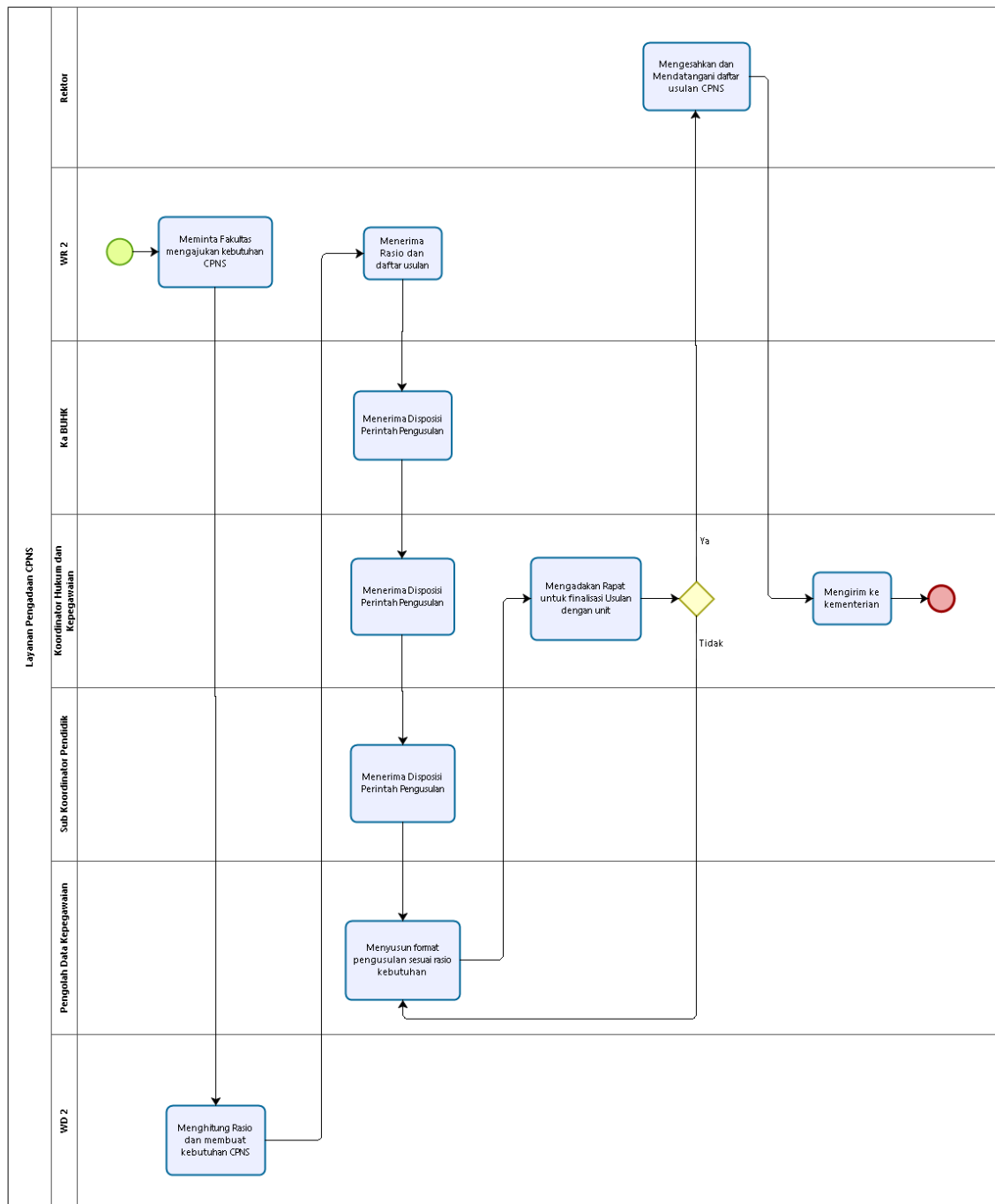

Level 4 Layanan Pengadaan Dosen Tetap Non PNS

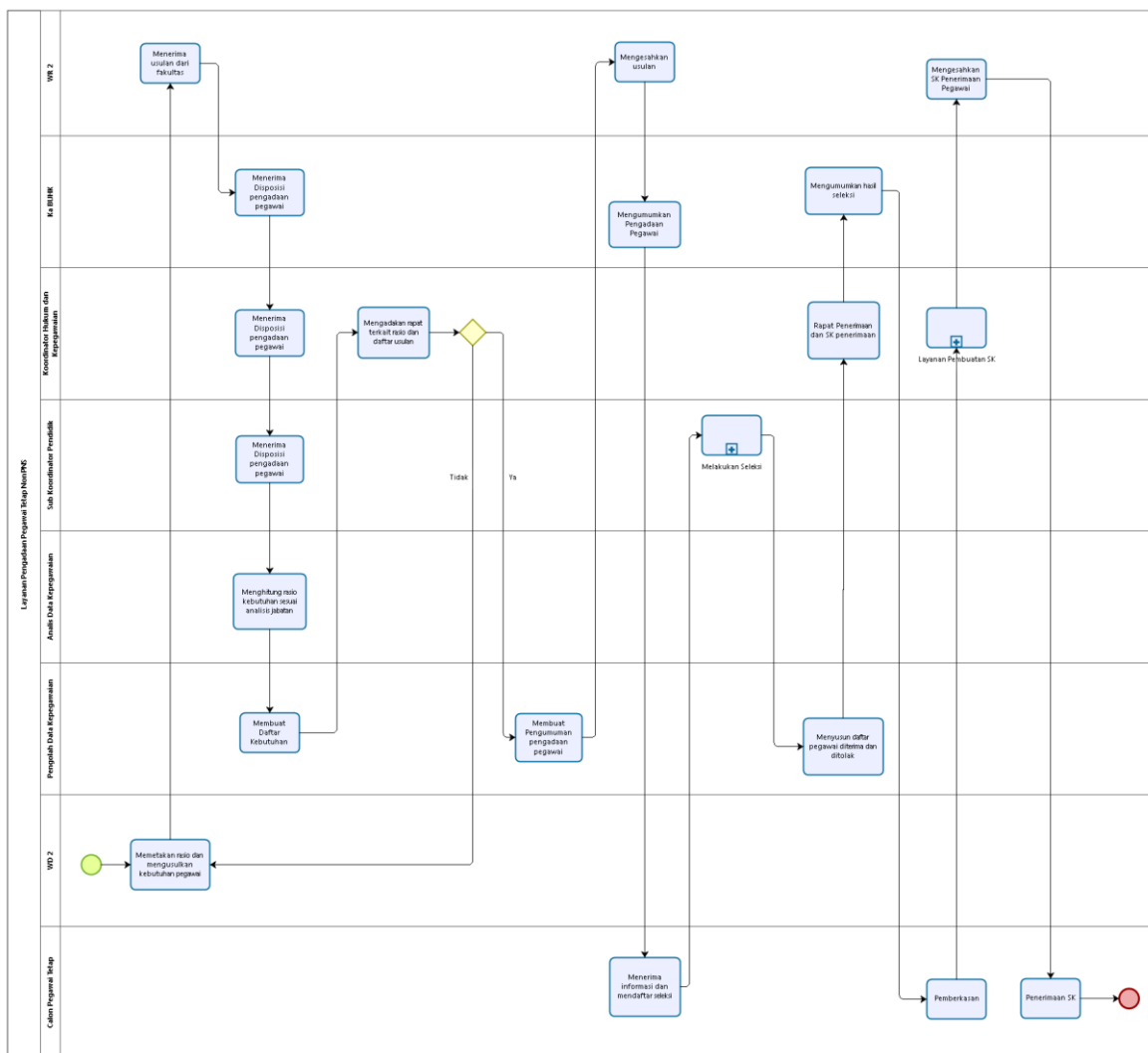

Level 4 Layanan Pengadaan Dosen Tidak Tetap Non PNS

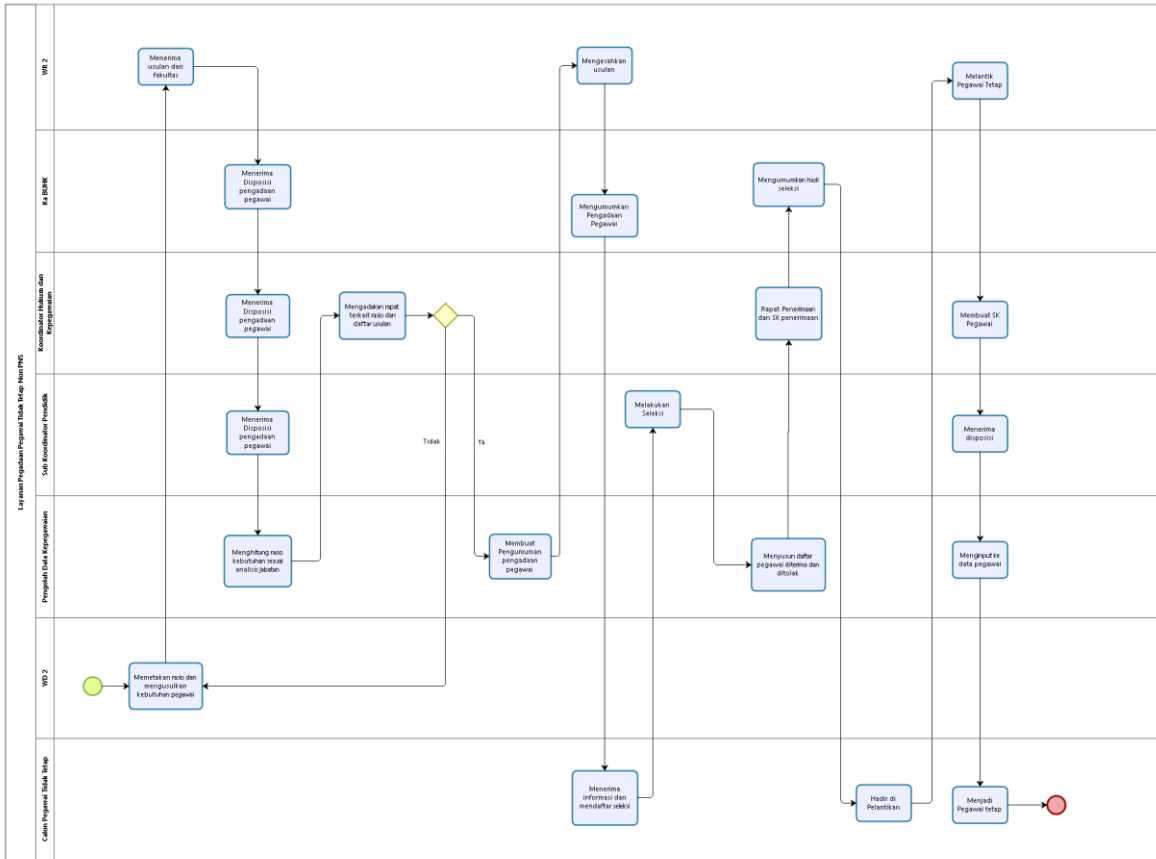

Level 4 Layanan Kenaikan Pangkat Bertahap

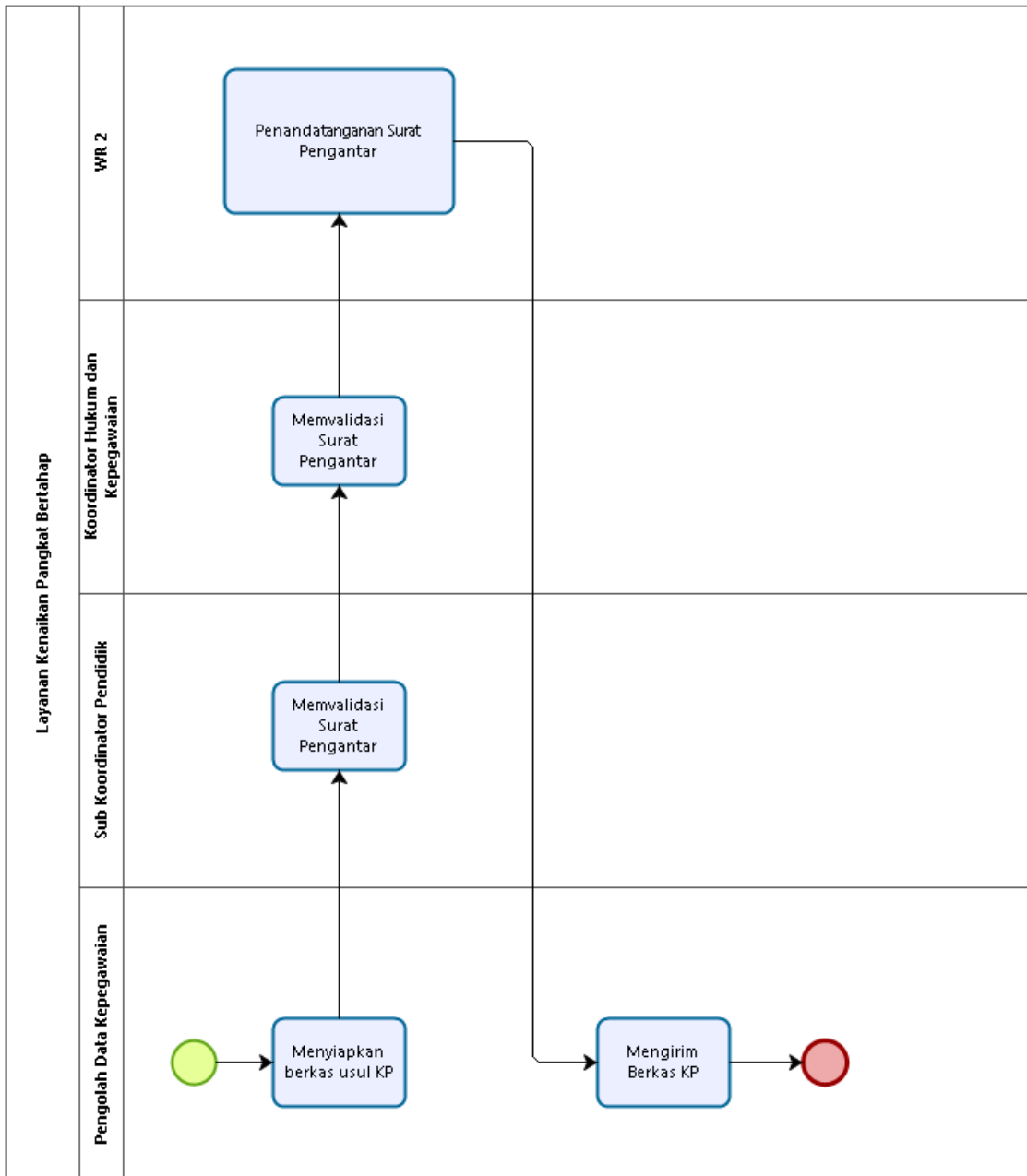

Level 4 Layanan Alih Tugas

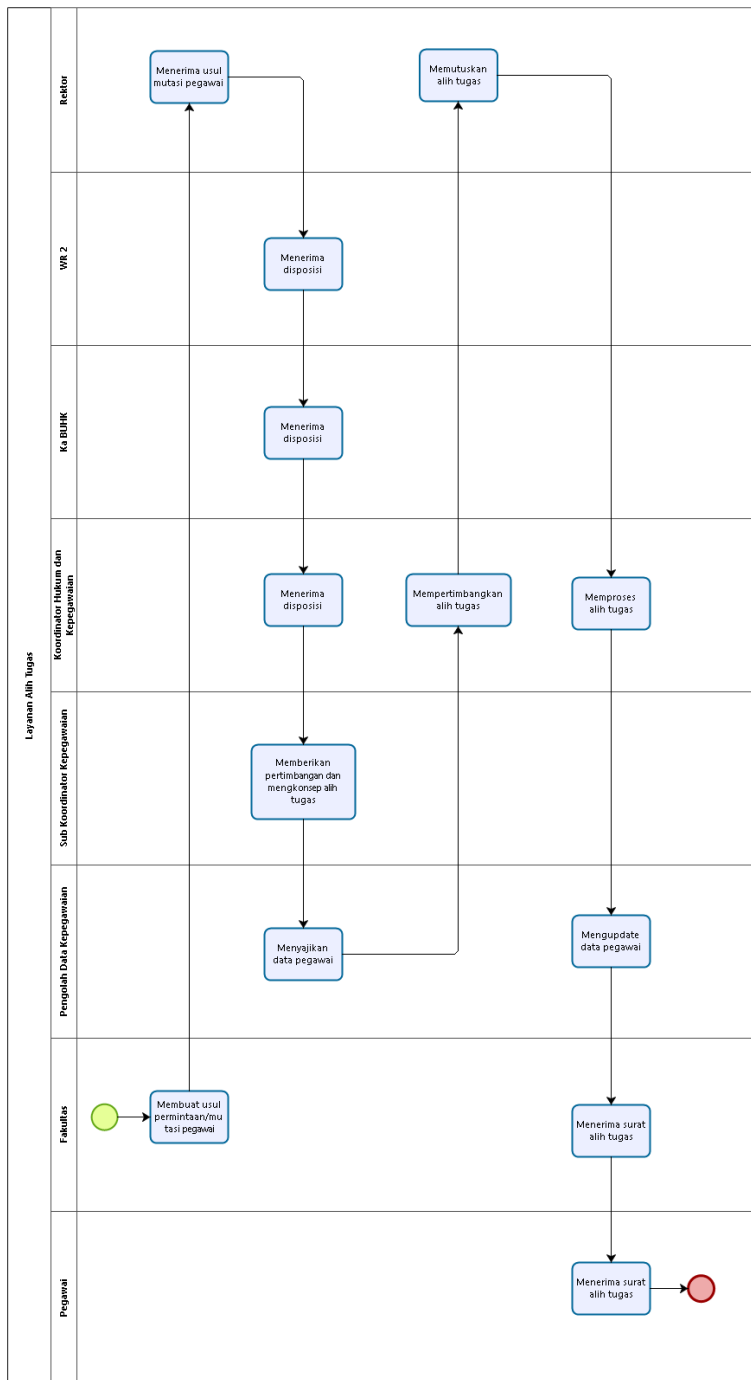

Powered by
bizagi
Modeler

Level 4 Layanan Pensiun Dosen

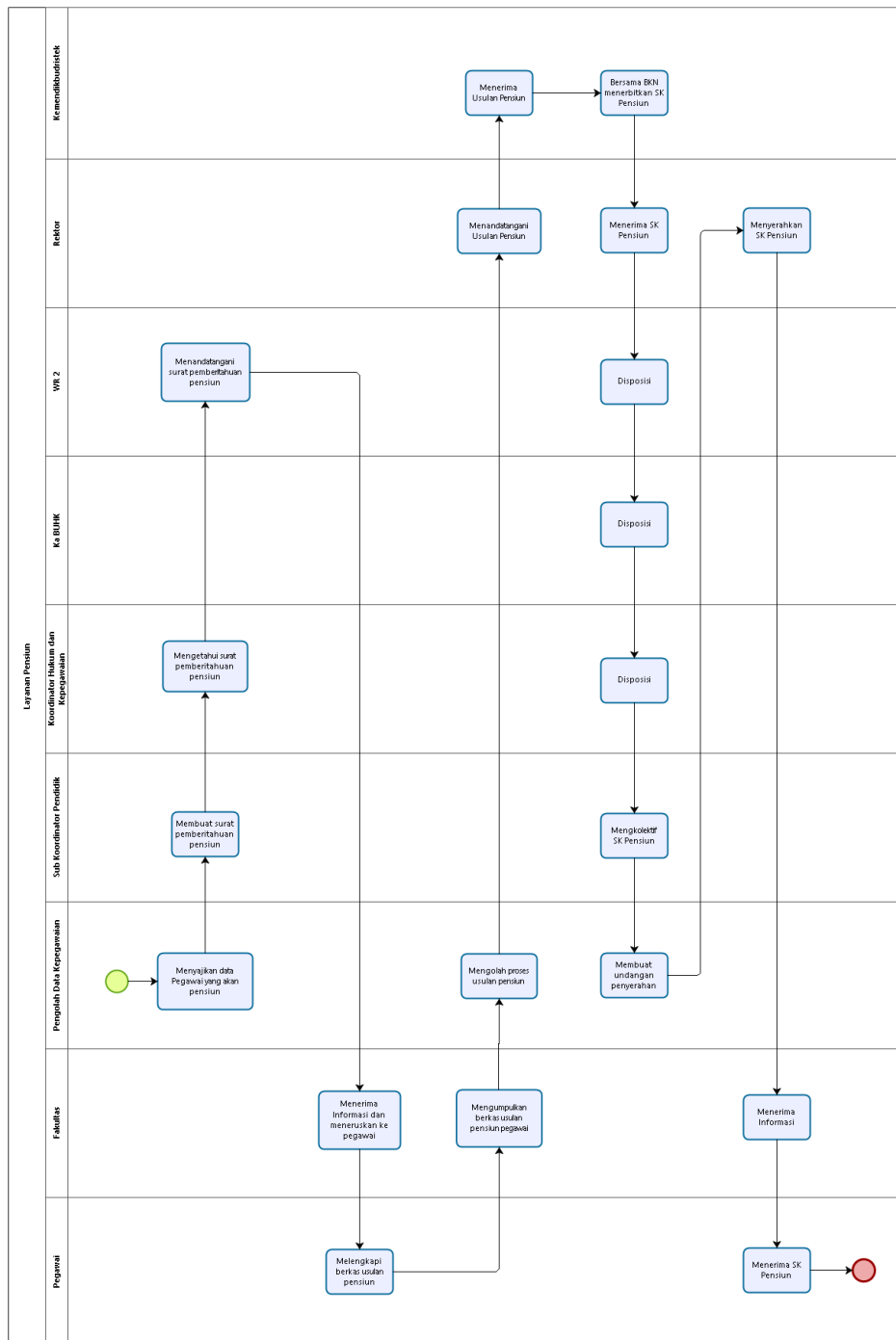

Powered by bizagi Model

Level 4 Layanan Studi Lanjut Dosen

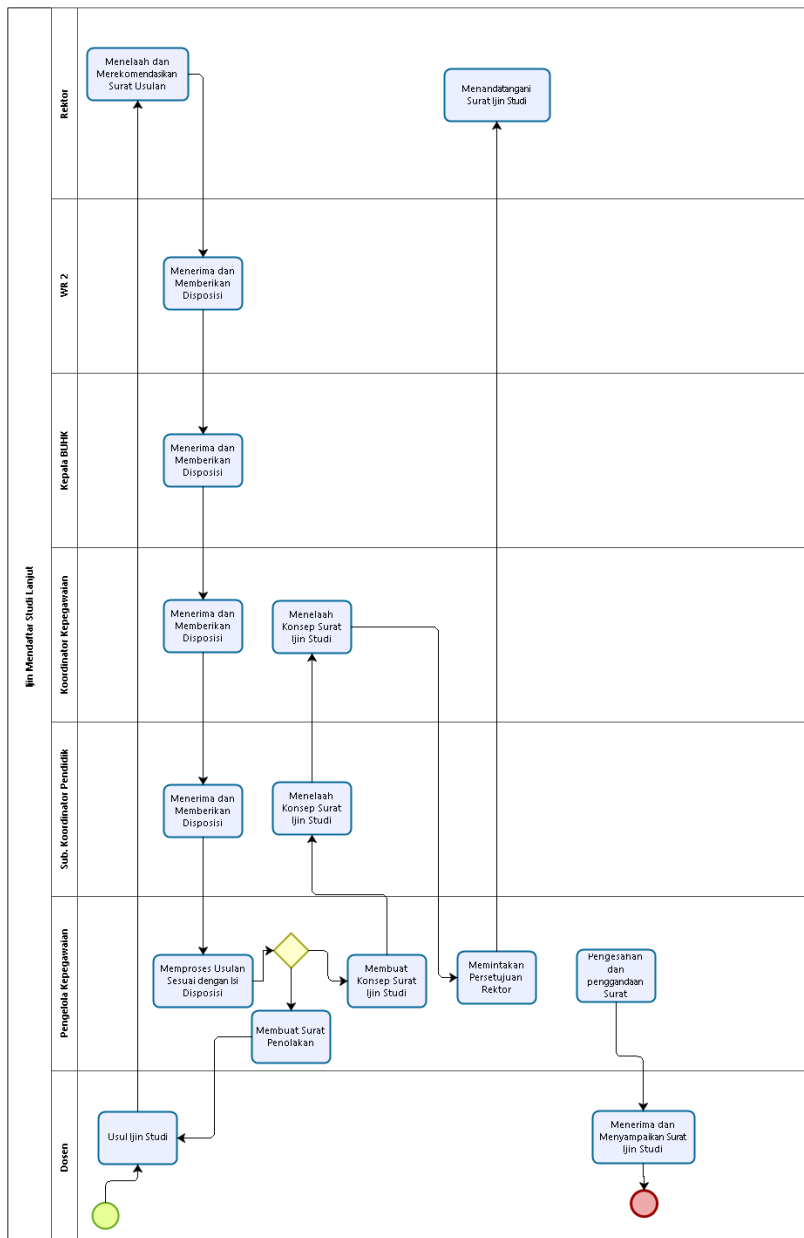

Diizinkan
Tidak Diizinkan

Powered by
bizagi
Modeler

Level 4 Layanan Pengusulan Karis / Karsu

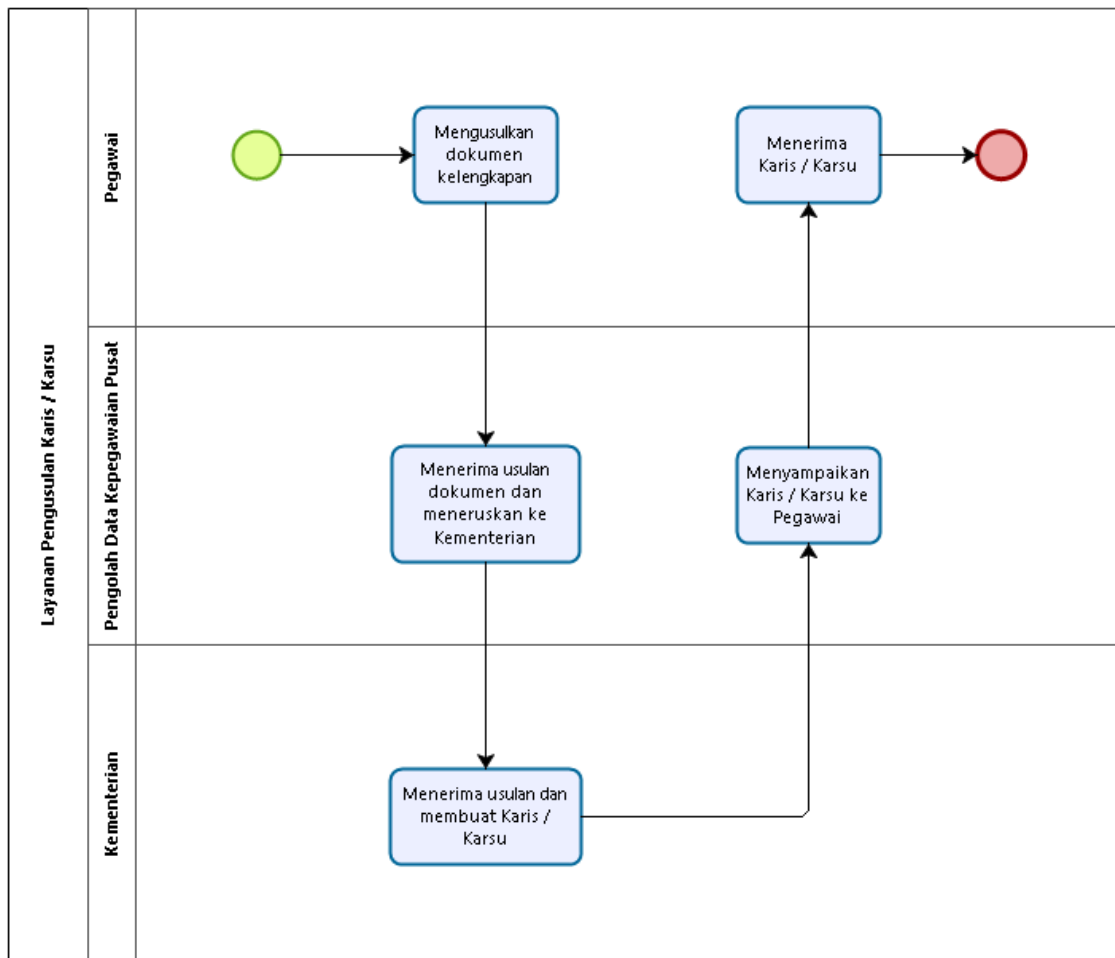

Level 4 Layanan Pembayaran Sertifikasi Dosen

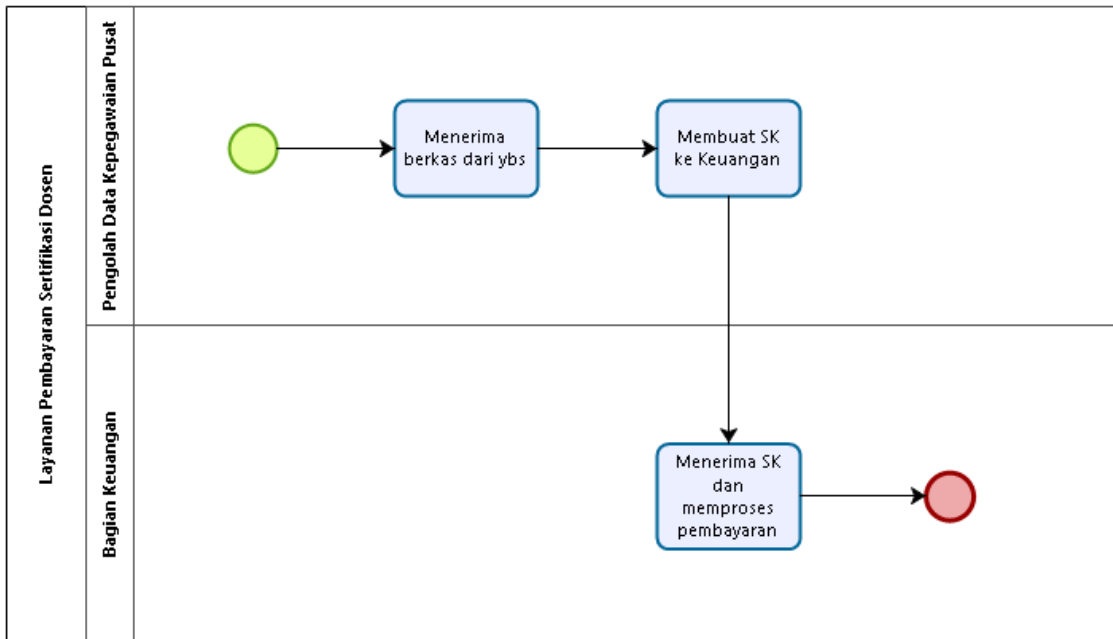

Level 4 Layanan KP4

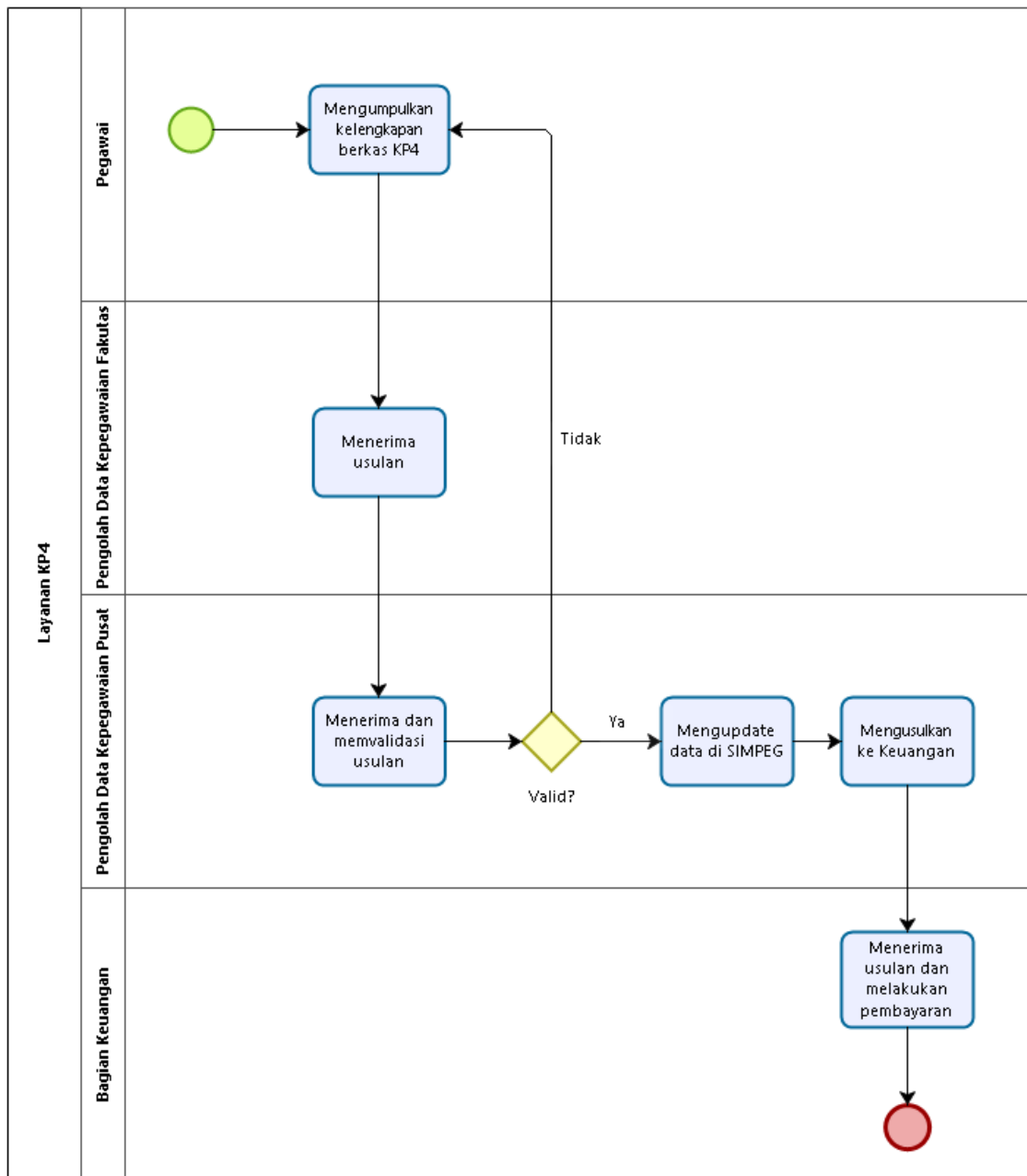

Level 4 Layanan Satya Lencana Dosen

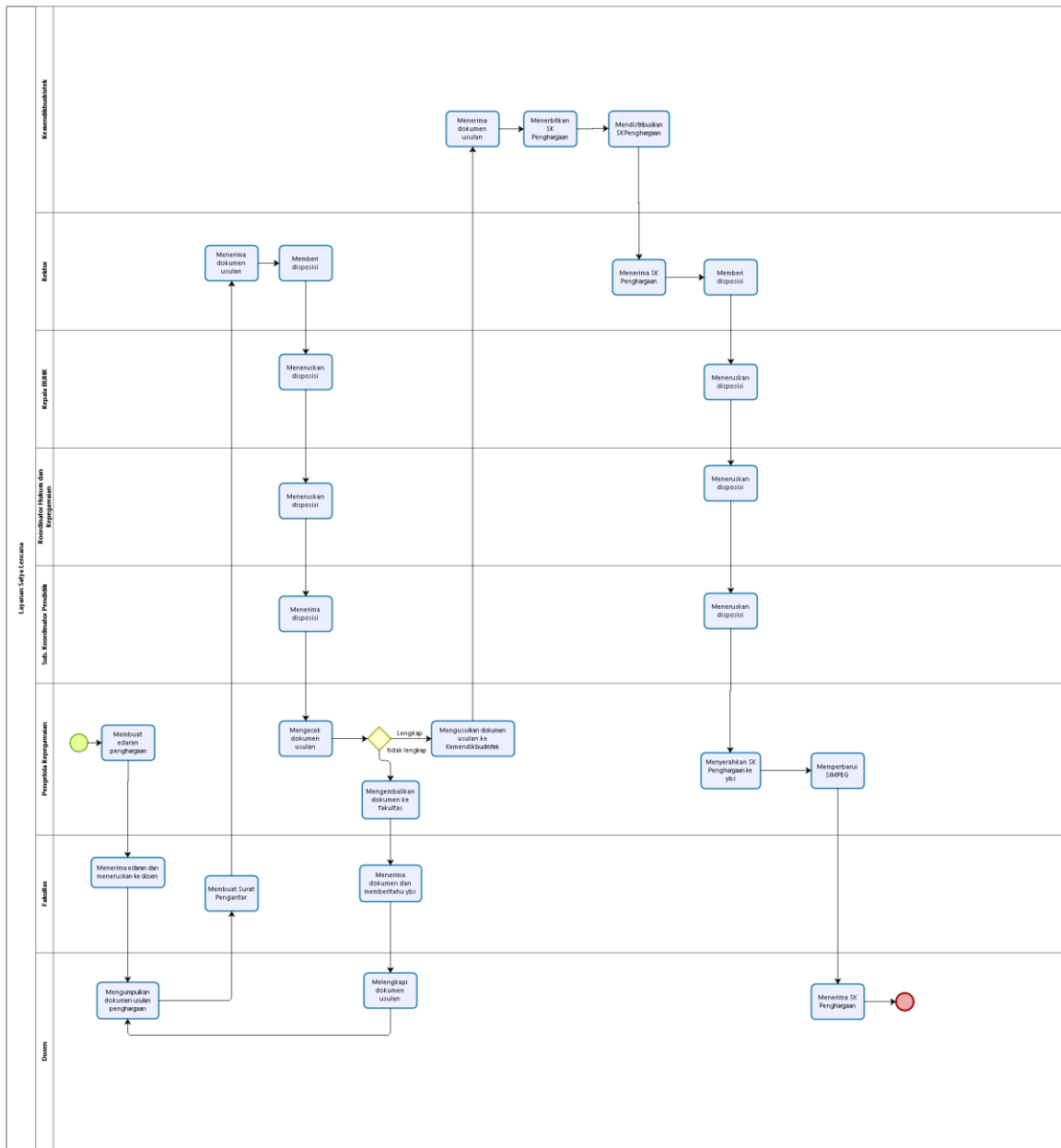

Level 4 Layanan SPKGB / PGP

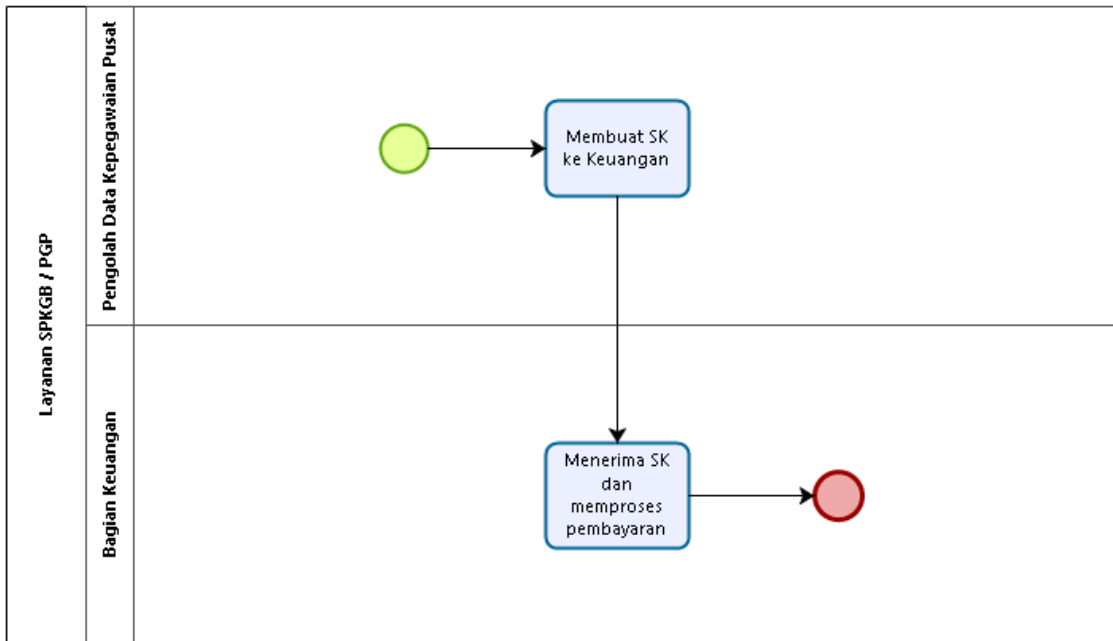

Powered by
bizagi
Modeler

Level 4 Layanan Cuti Dosen

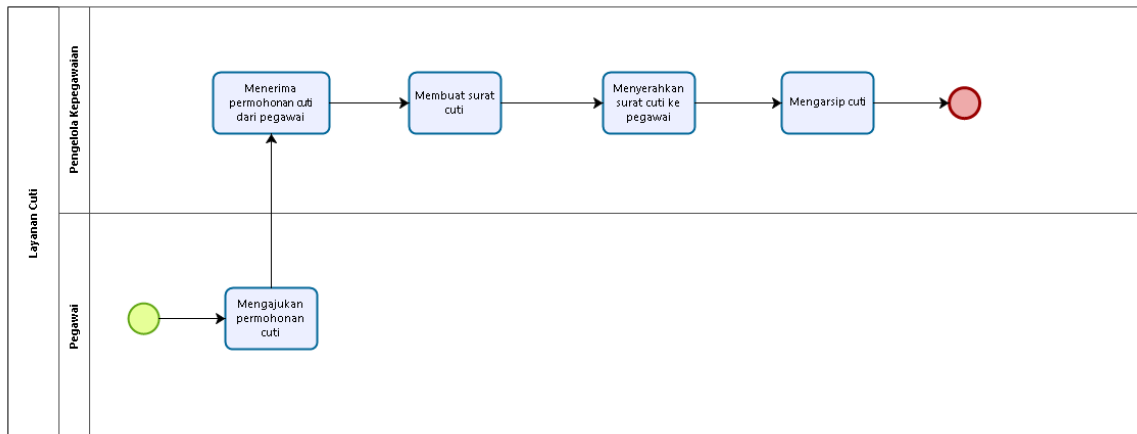

Powered by
bizagi
Modeler

Level 4 Layanan Surat Masuk dan Surat Keluar

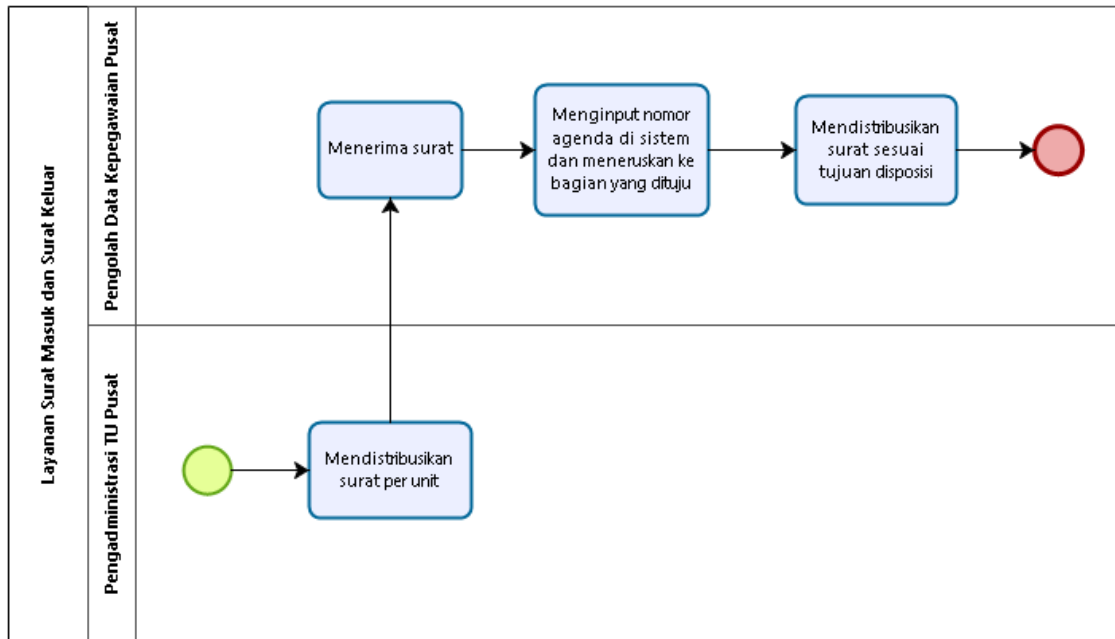

Level 4 Layanan Pemecatan

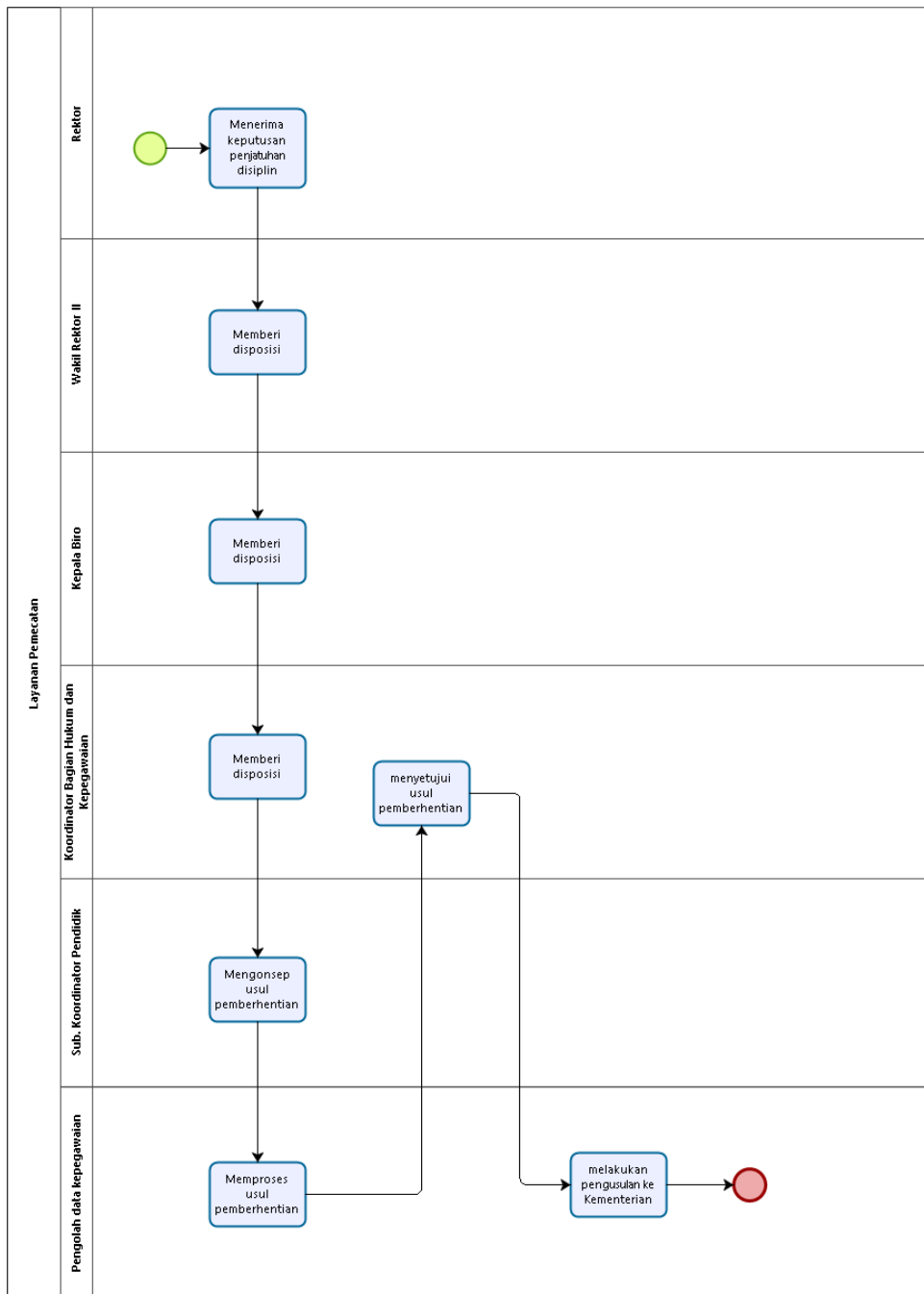

Level 4 Layanan SISTER

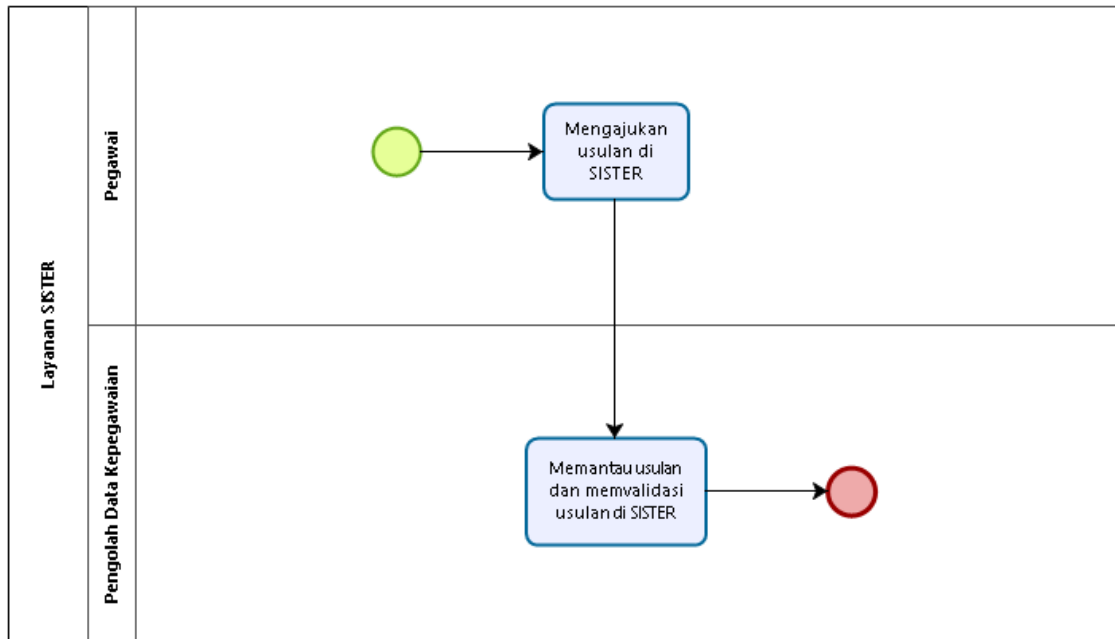

Level 3 Layanan Tenaga Kependidikan

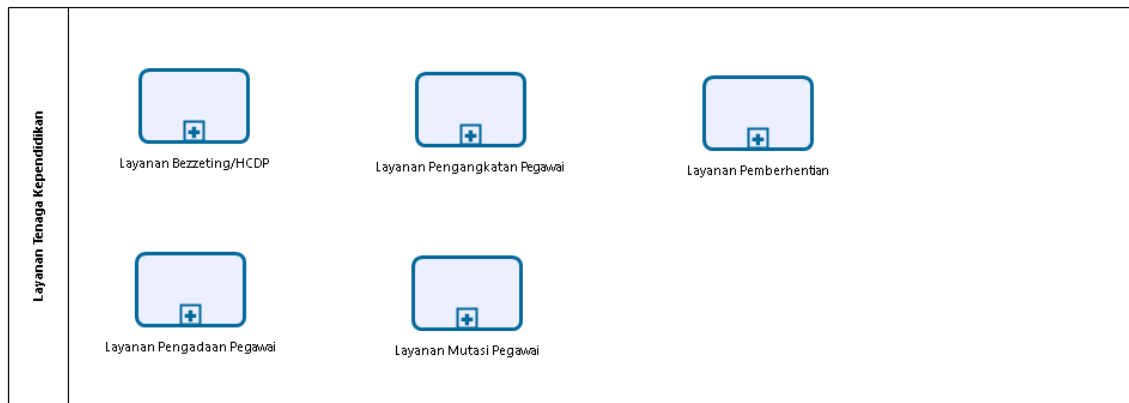

Level 4 Layanan Bezzeting

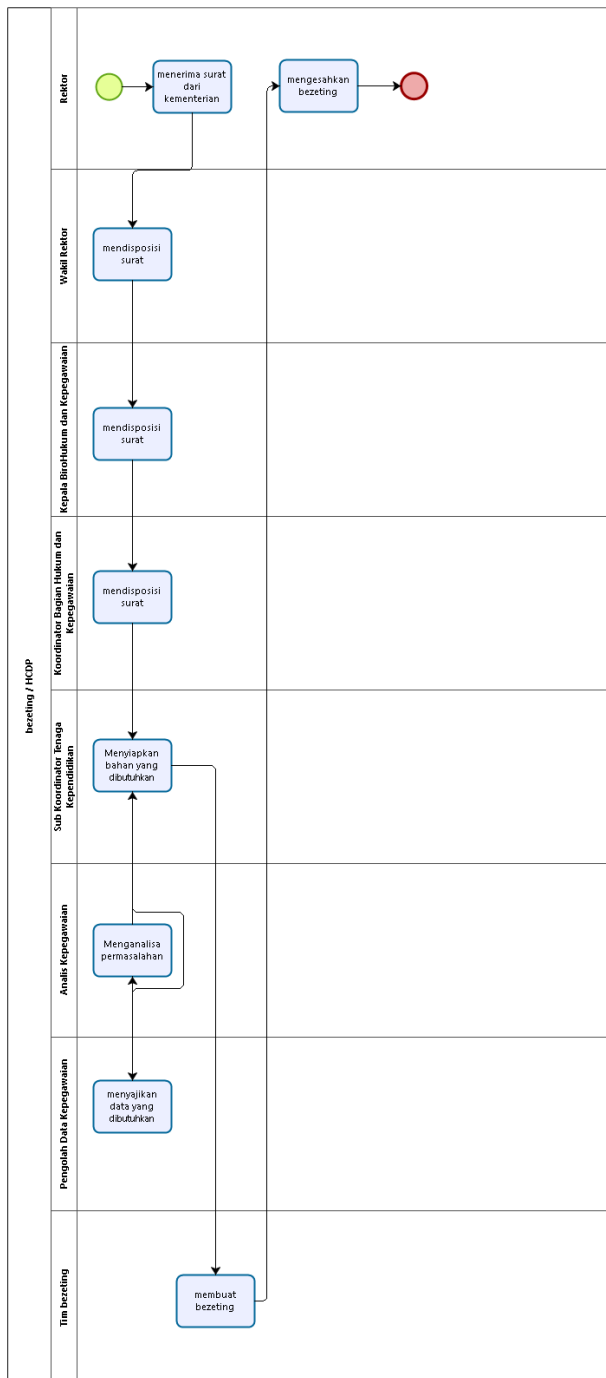

Level 4 Layanan Pengangkatan Pegawai

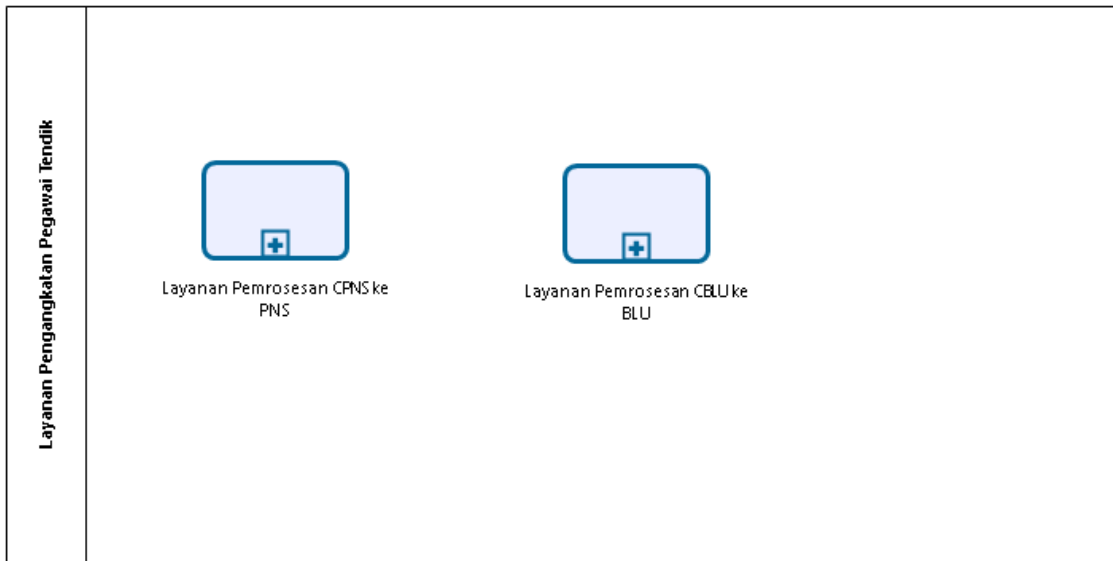

Level 5 Layanan Pemrosesan CPNS ke PNS

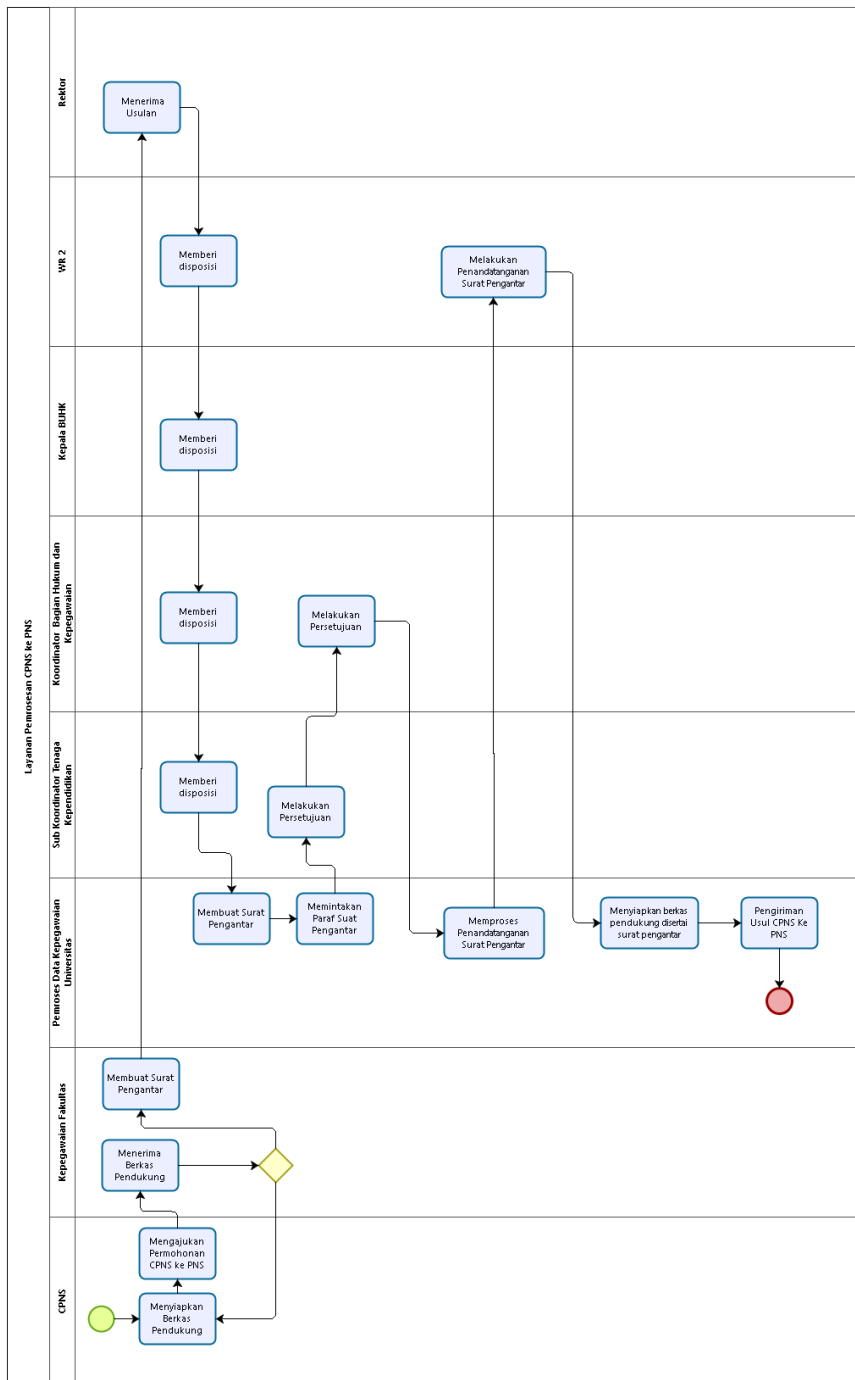

Level 4 Layanan Pemberhentian Tenaga Kependidikan

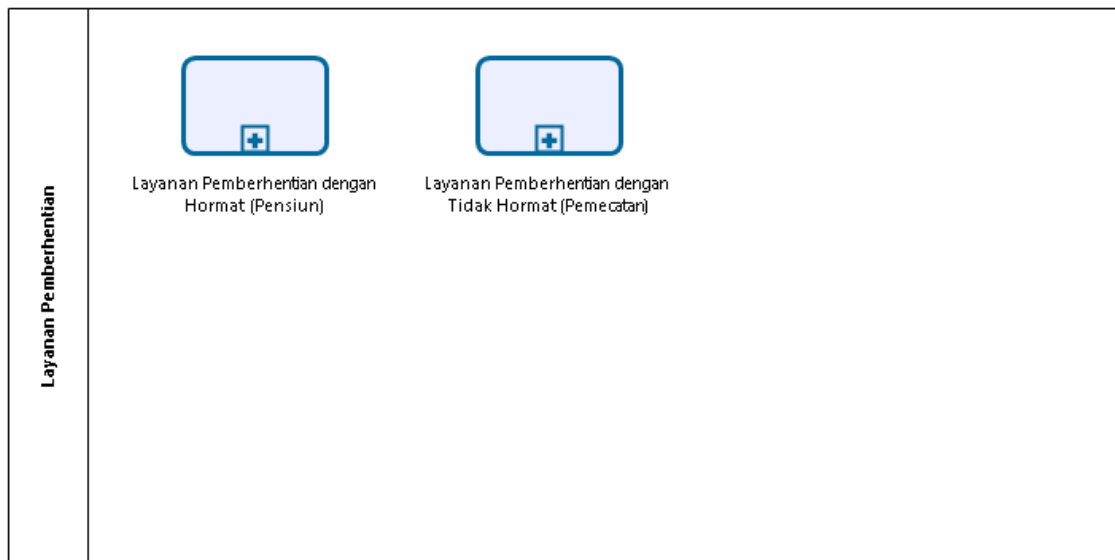

Level 5 Layanan Pemberhentian dengan Hormat (Pensiun)

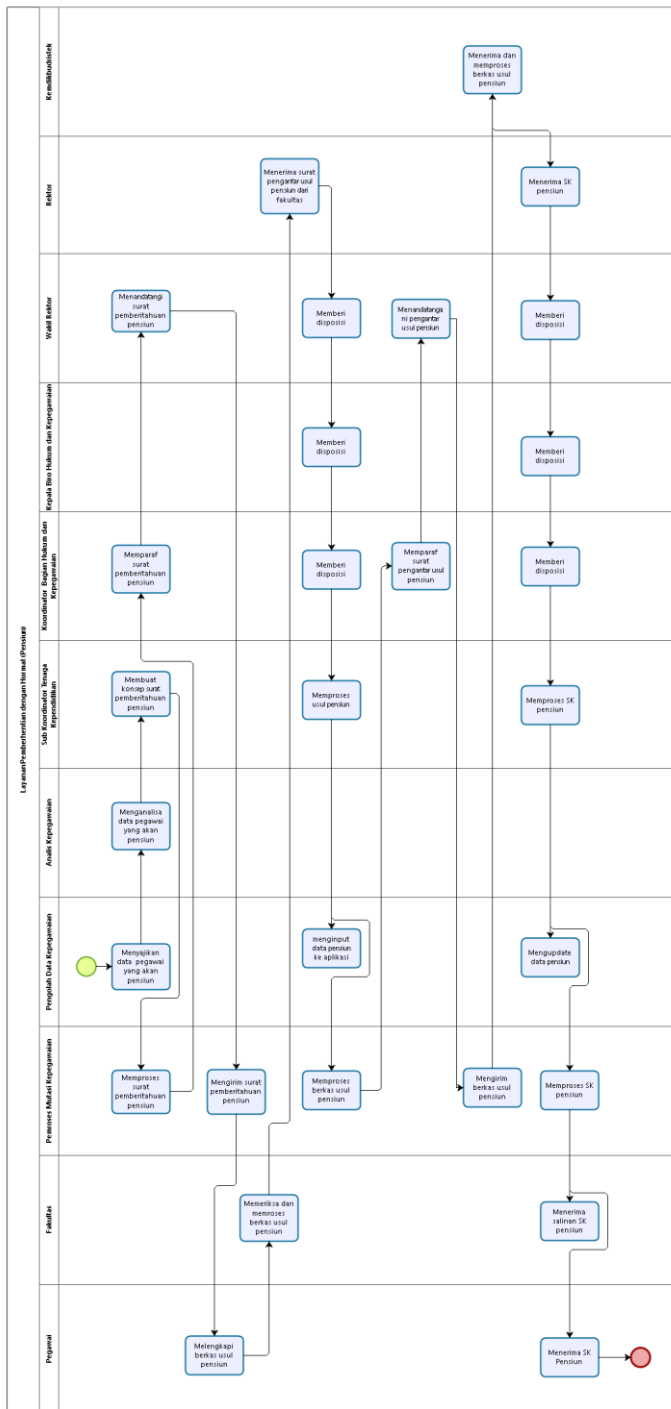

Level 5 Layanan Pemberhentian dengan Tidak Hormat (Pemecatan)

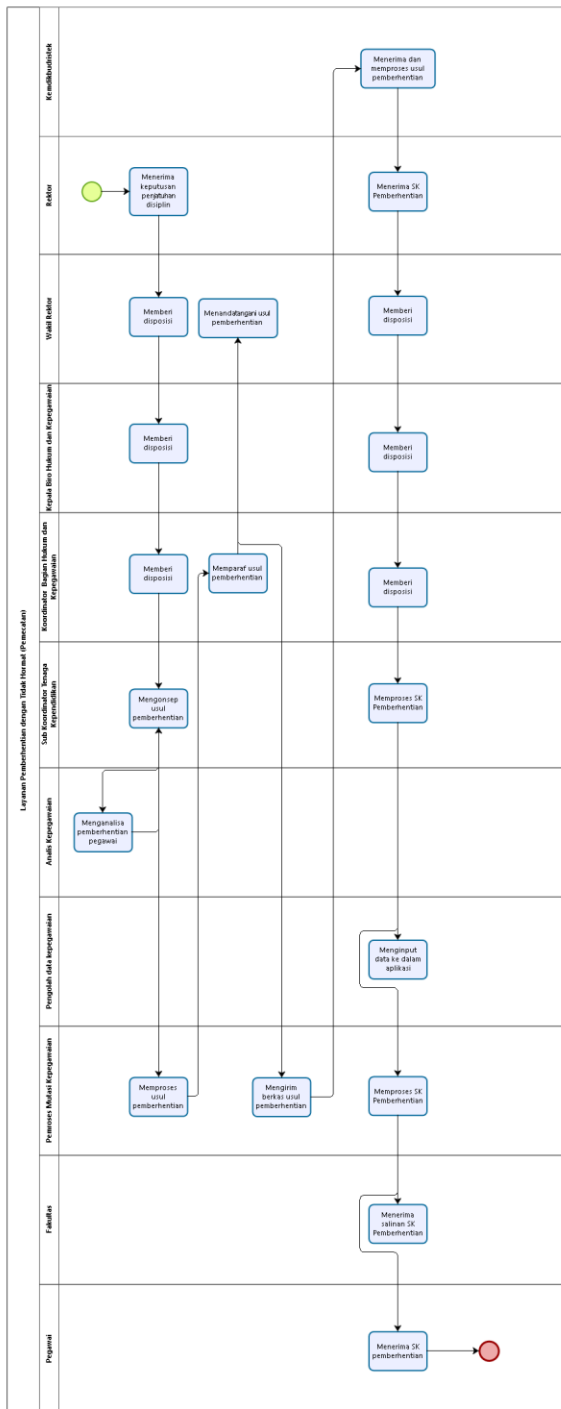

Level 4 Layanan Pengadaan Pegawai

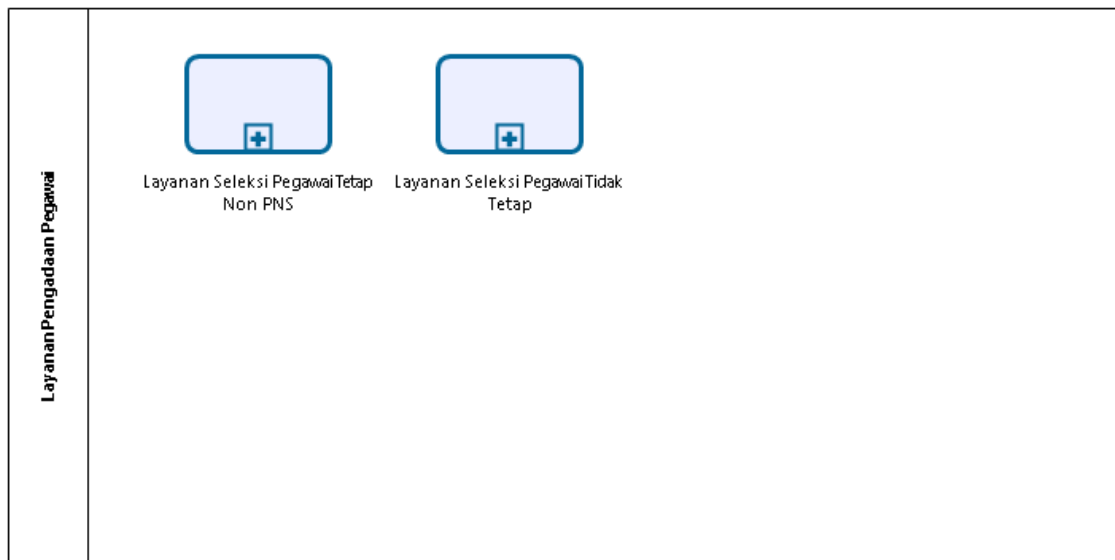

Level 5 Layanan Seleksi Pegawai Tetap Non PNS

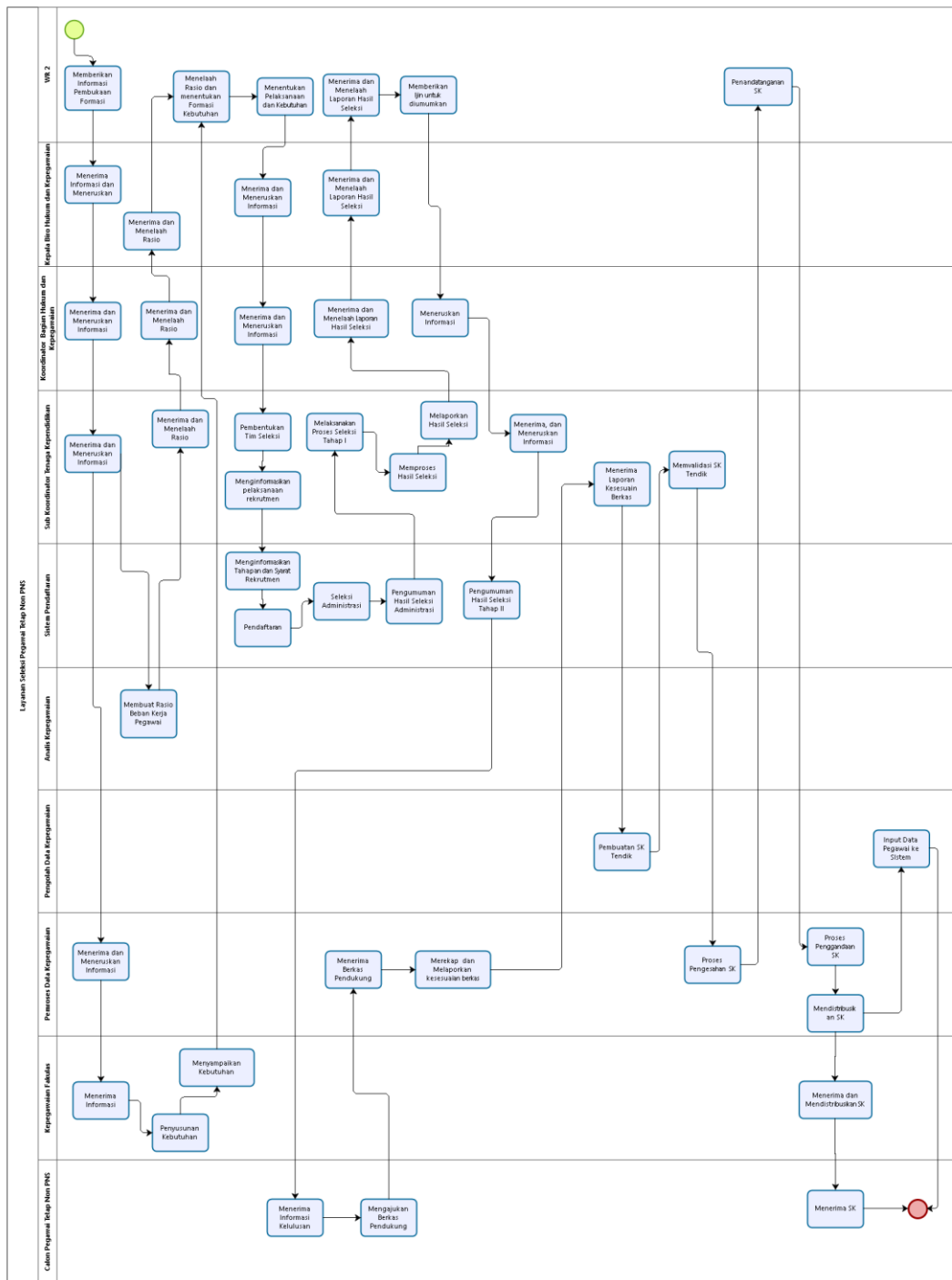

Powered by bizagi

Level 5 Layanan Seleksi Pegawai Tidak Tetap

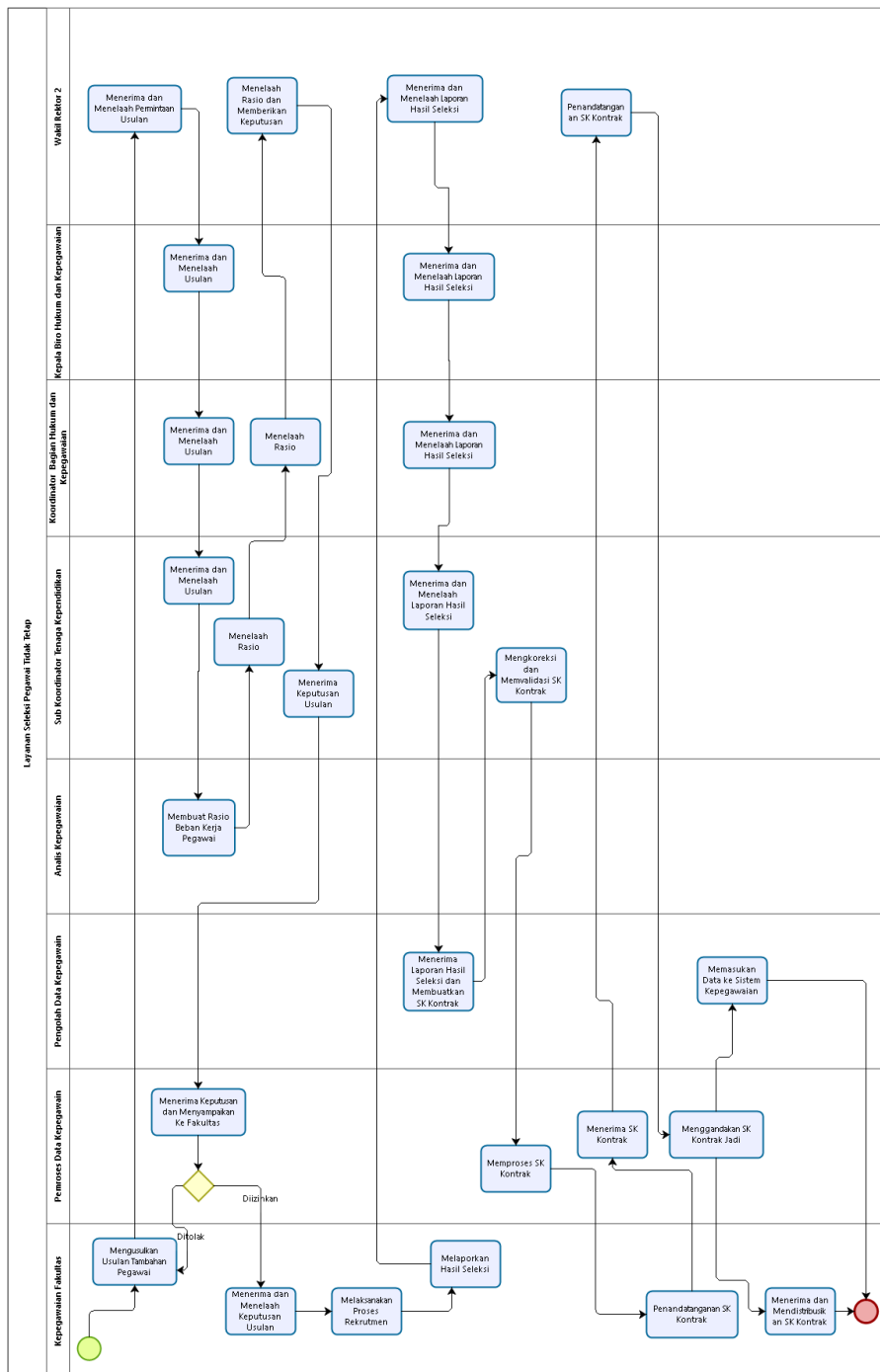

Level 4 Layanan Mutasi Pegawai

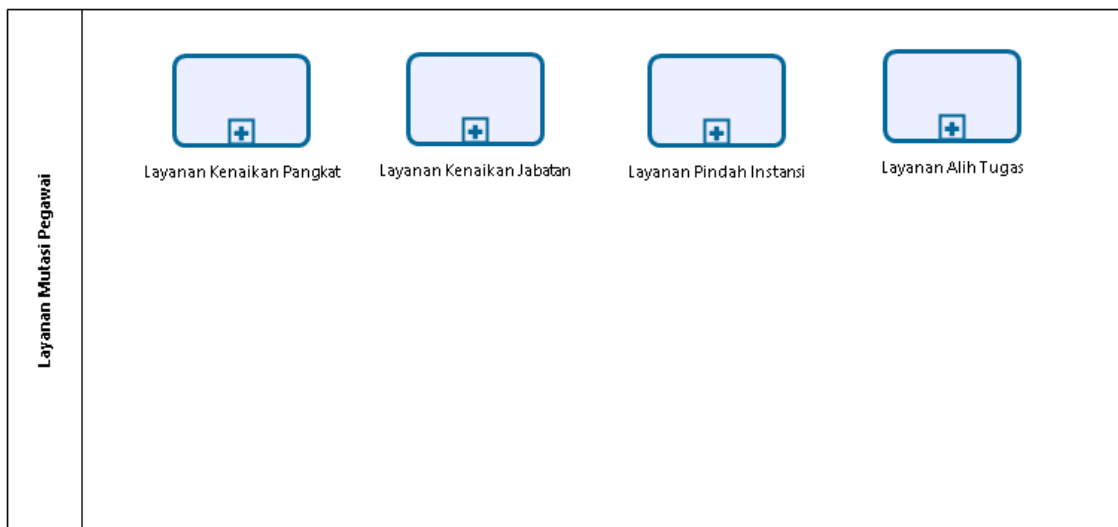

Level 5 Layanan Kenaikan Jabatan

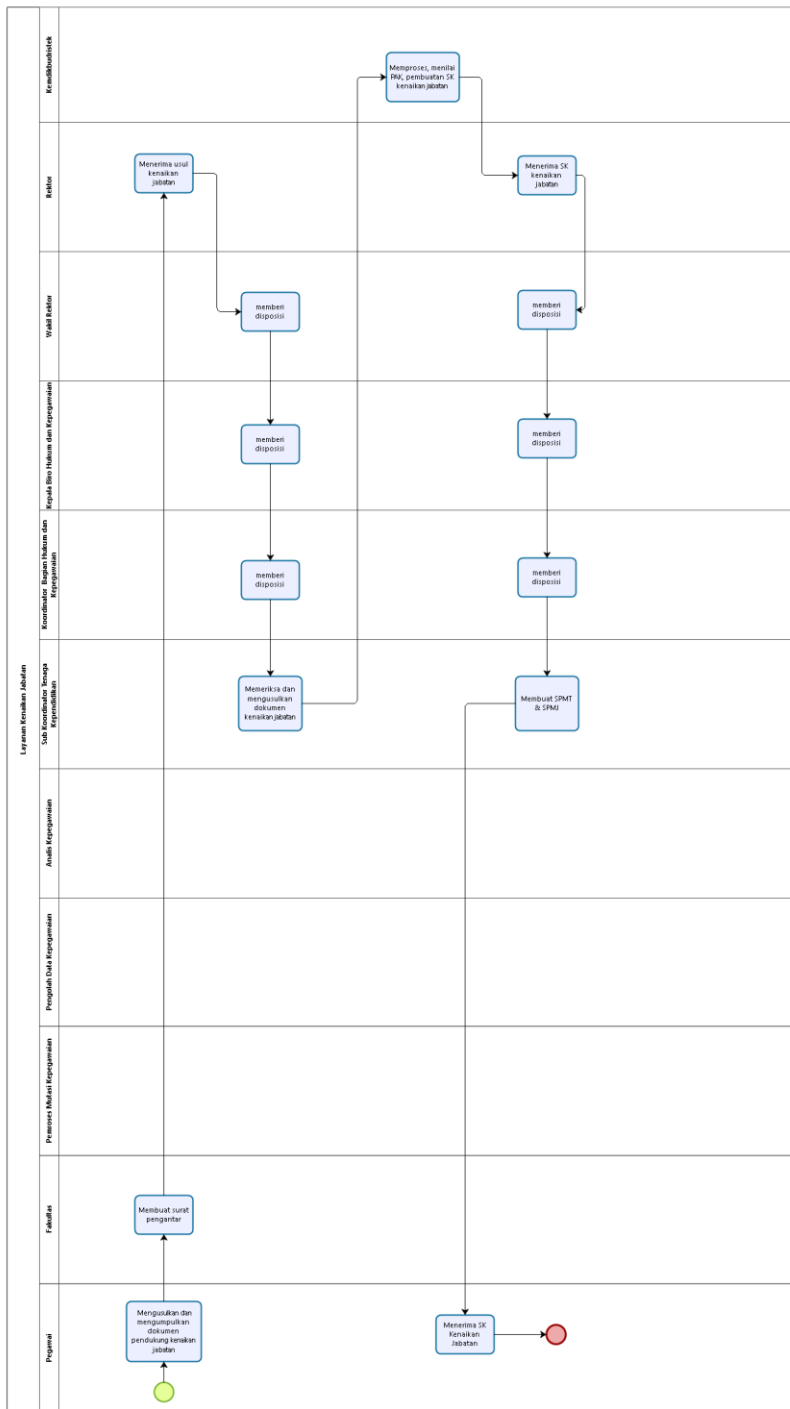

Level 5 Layanan Pindah Instansi

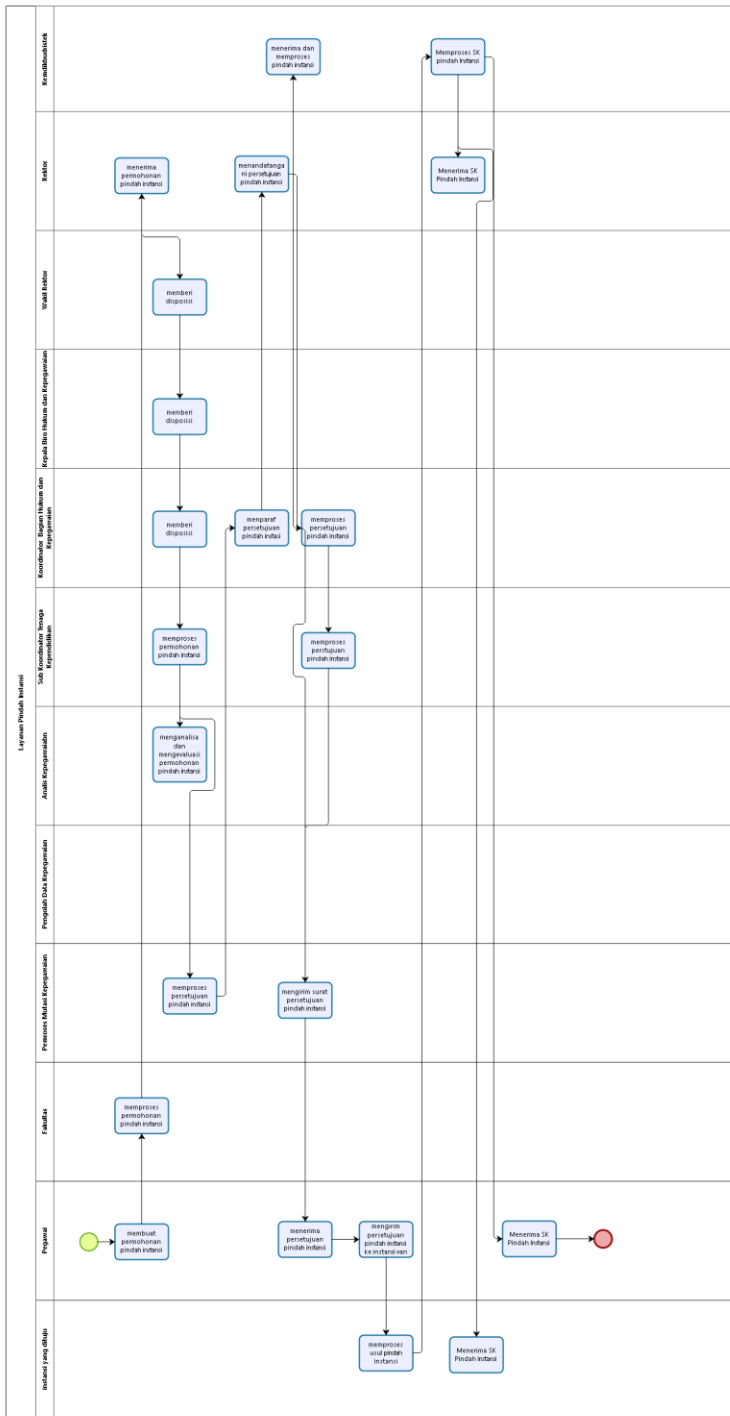

Level 5 Layanan Alih Tugas

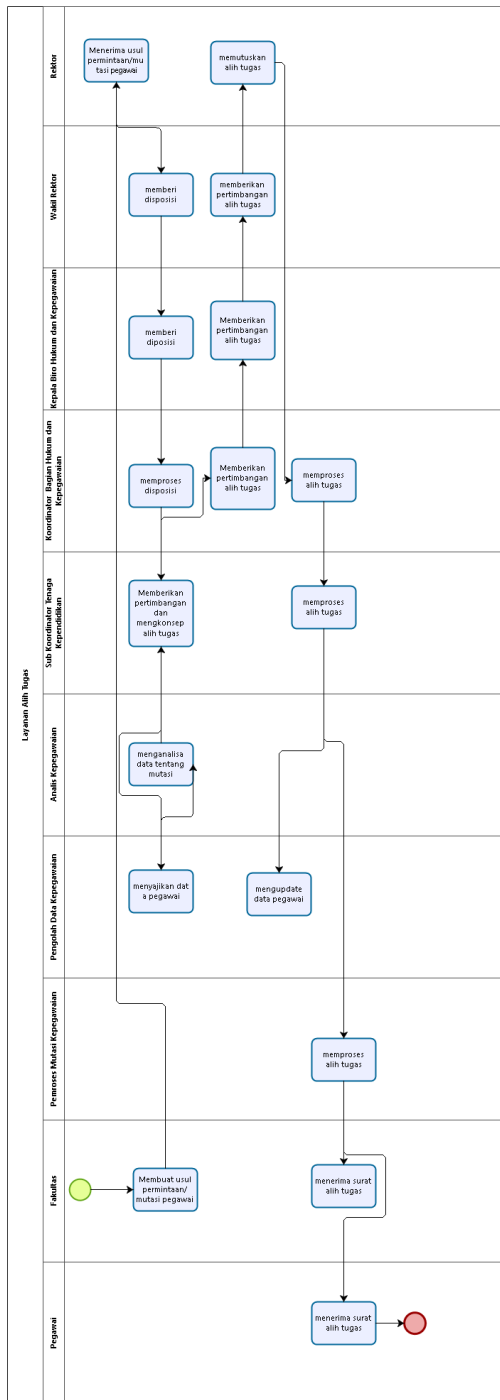

Level 1 Layanan Perencanaan dan Keuangan

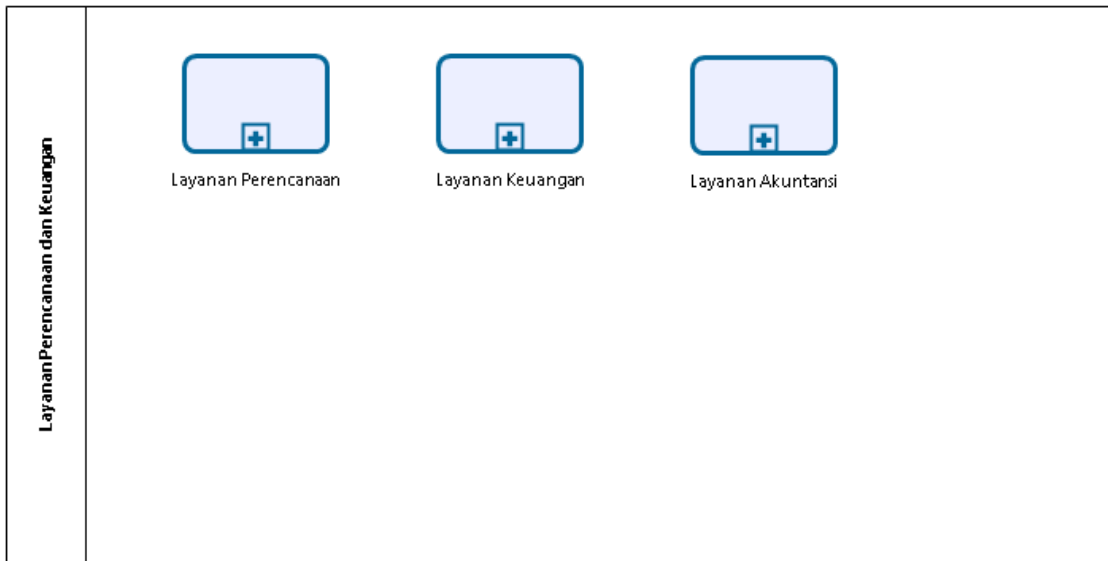

Powered by
bizagi
Modeler

Level 2 Layanan Perencanaan

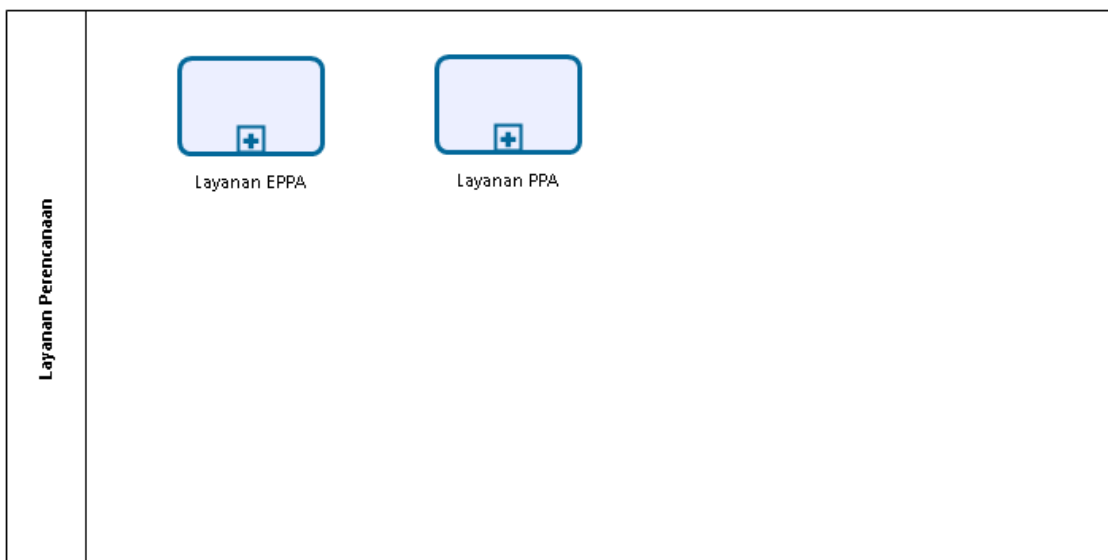

Powered by
bizagi
Modeler

Level 3 Layanan EPPA

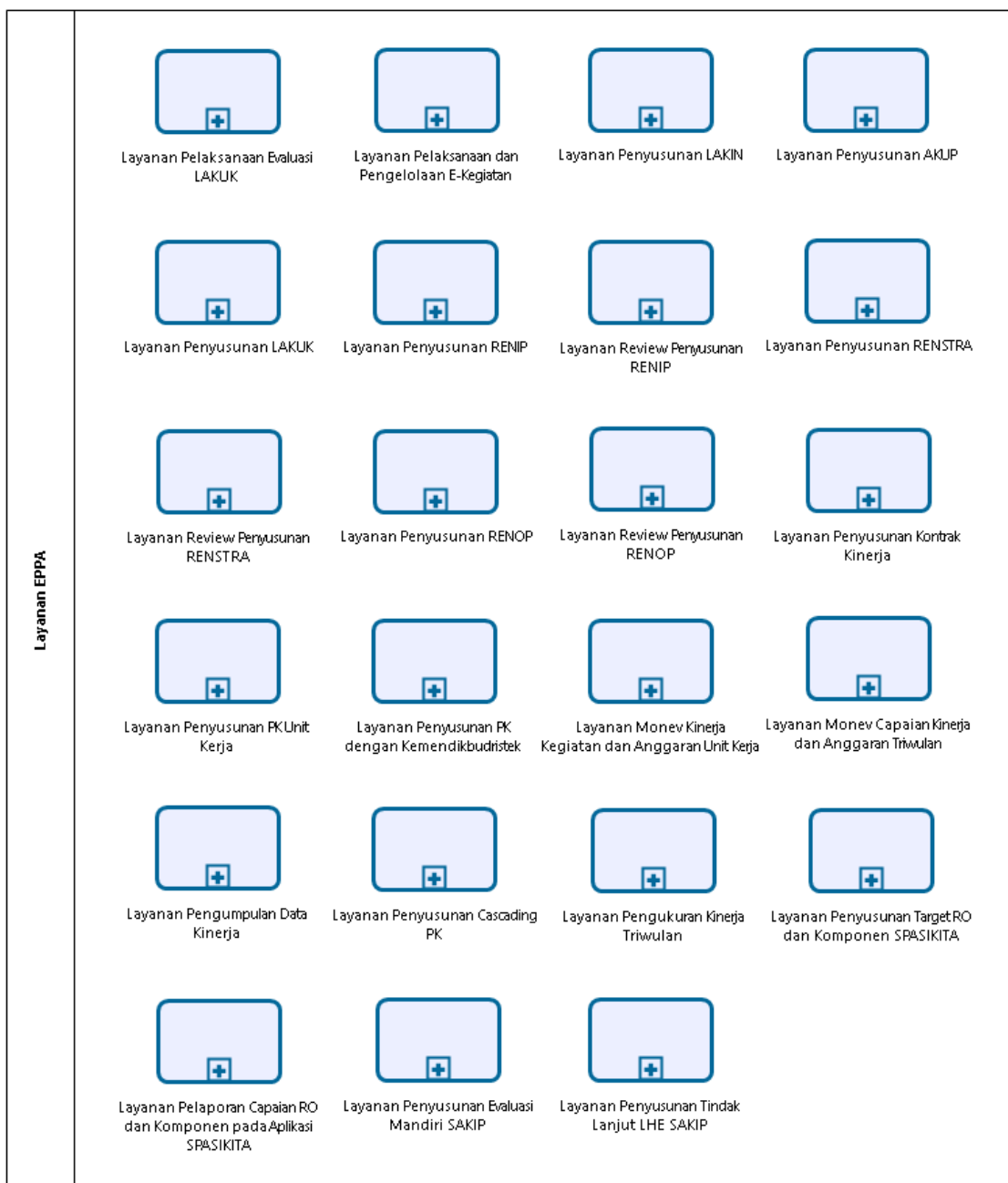

Level 4 Layanan Pelaksanaan Evaluasi LAKUK

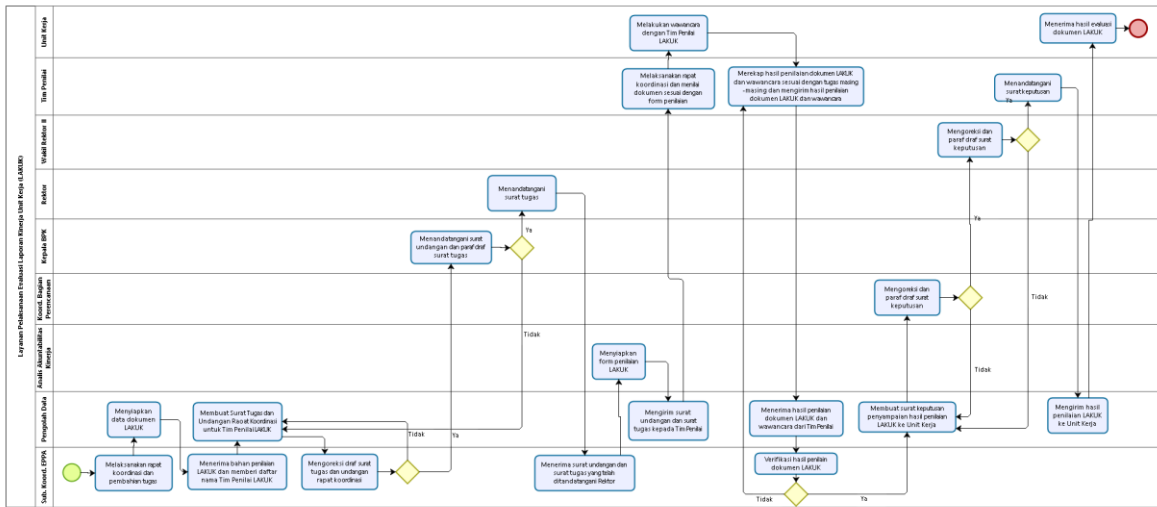

Powered by
bizagi
Modeler

Level 4 Layanan Pelaksanaan dan Pengelolaan E-Kegiatan

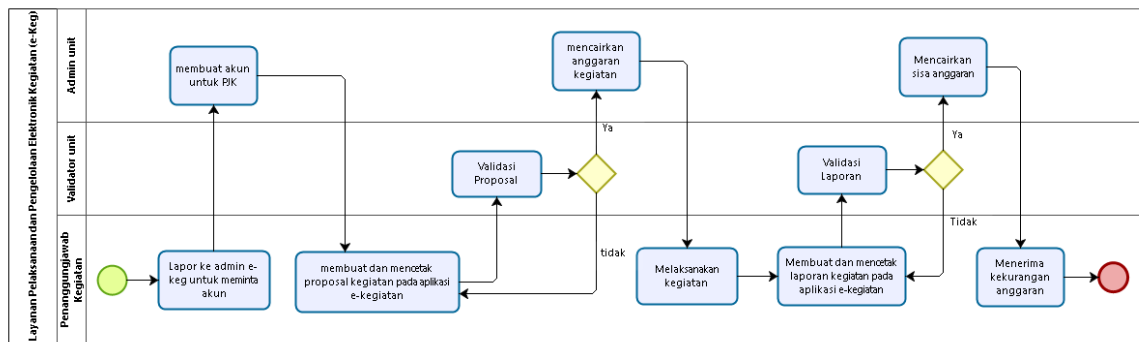

Powered by
bizagi
Modeler

Level 4 Layanan Penyusunan LAKIN (Laporan Kinerja)

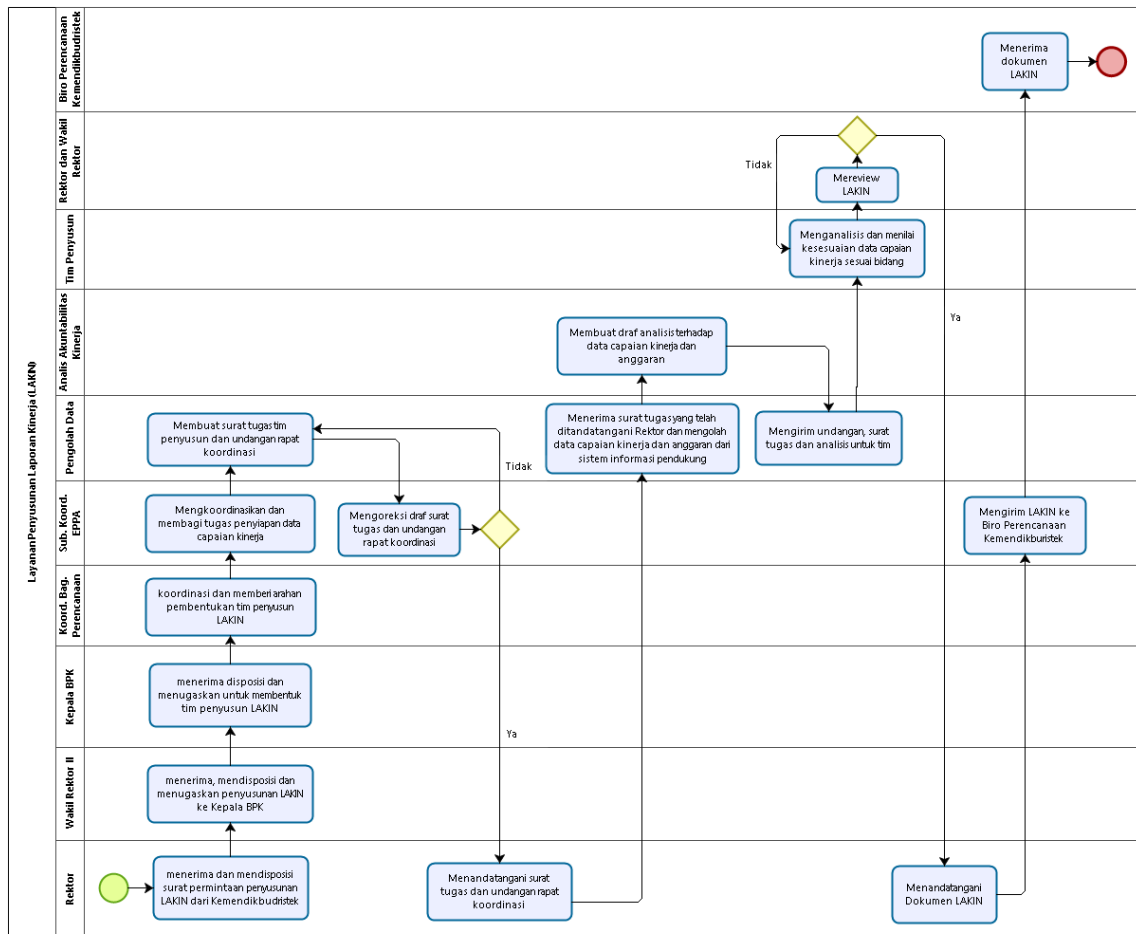

Level 4 Layanan Penyusunan AKUP

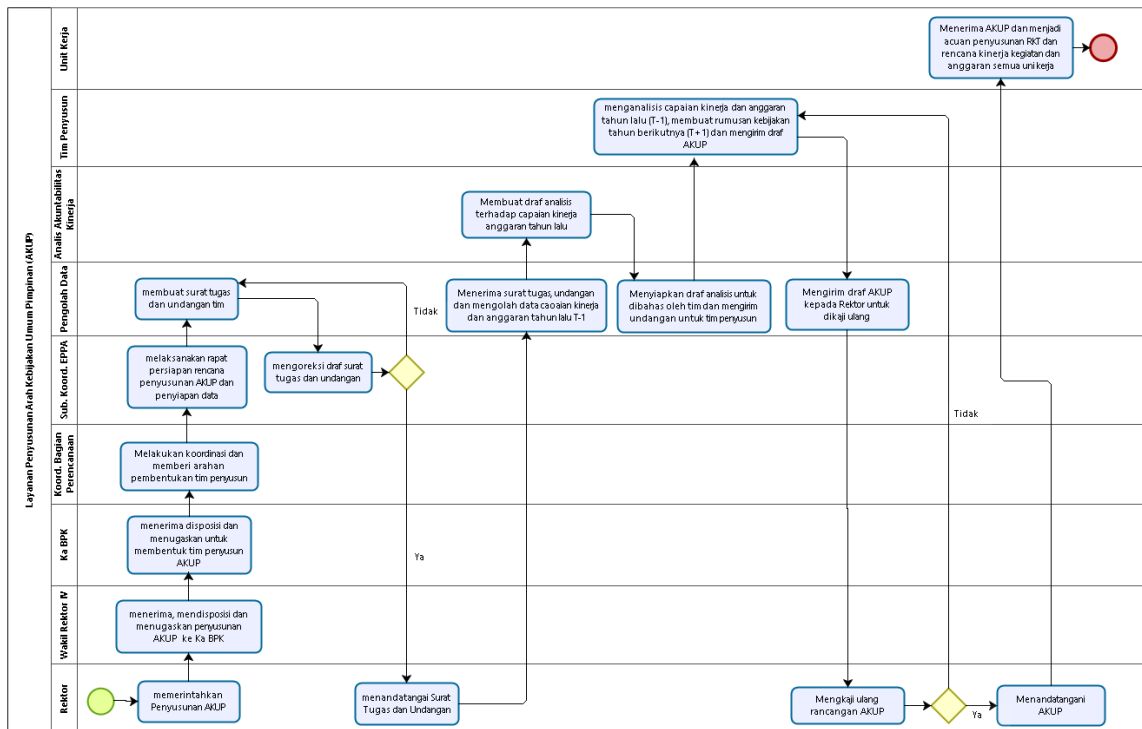

Powered by
bizagi
Modeler

Level 4 Layanan Penyusunan LAKUK

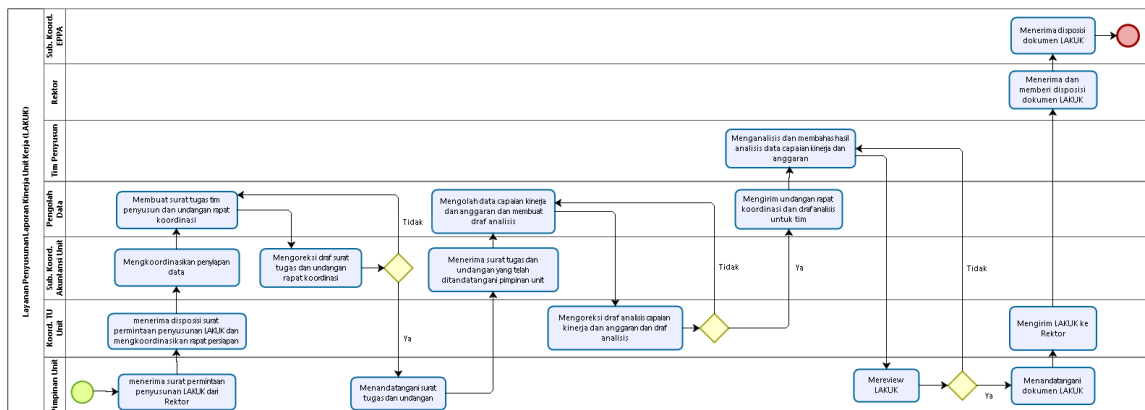

Powered by
bizagi
Modeler

Level 4 Layanan Penyusunan RENIP

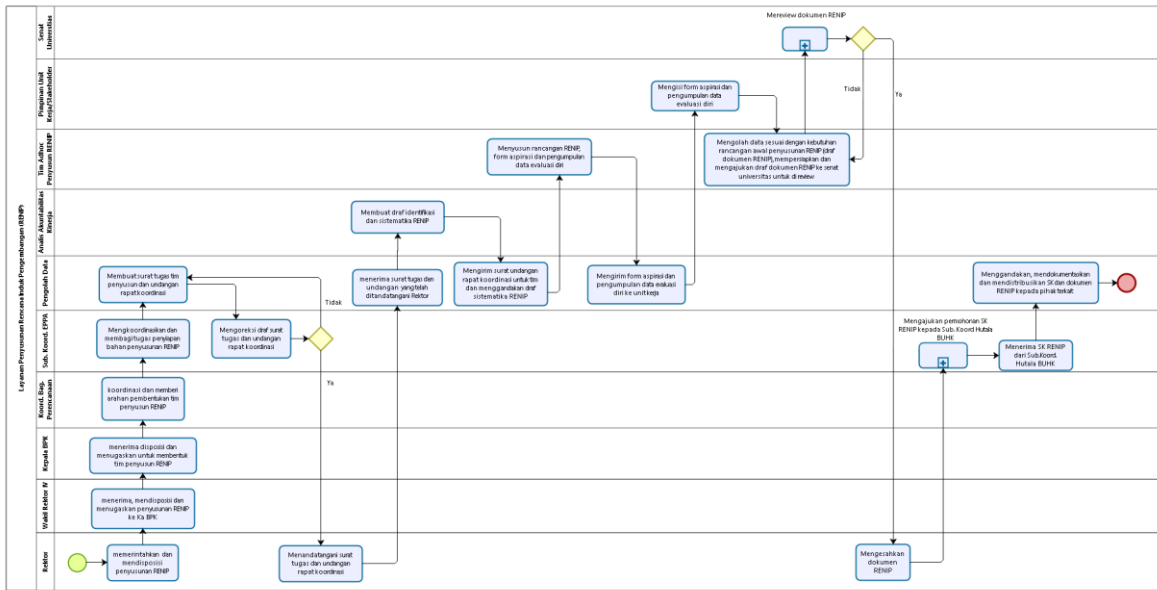

Level 4 Layanan Review Penyusunan RENIP

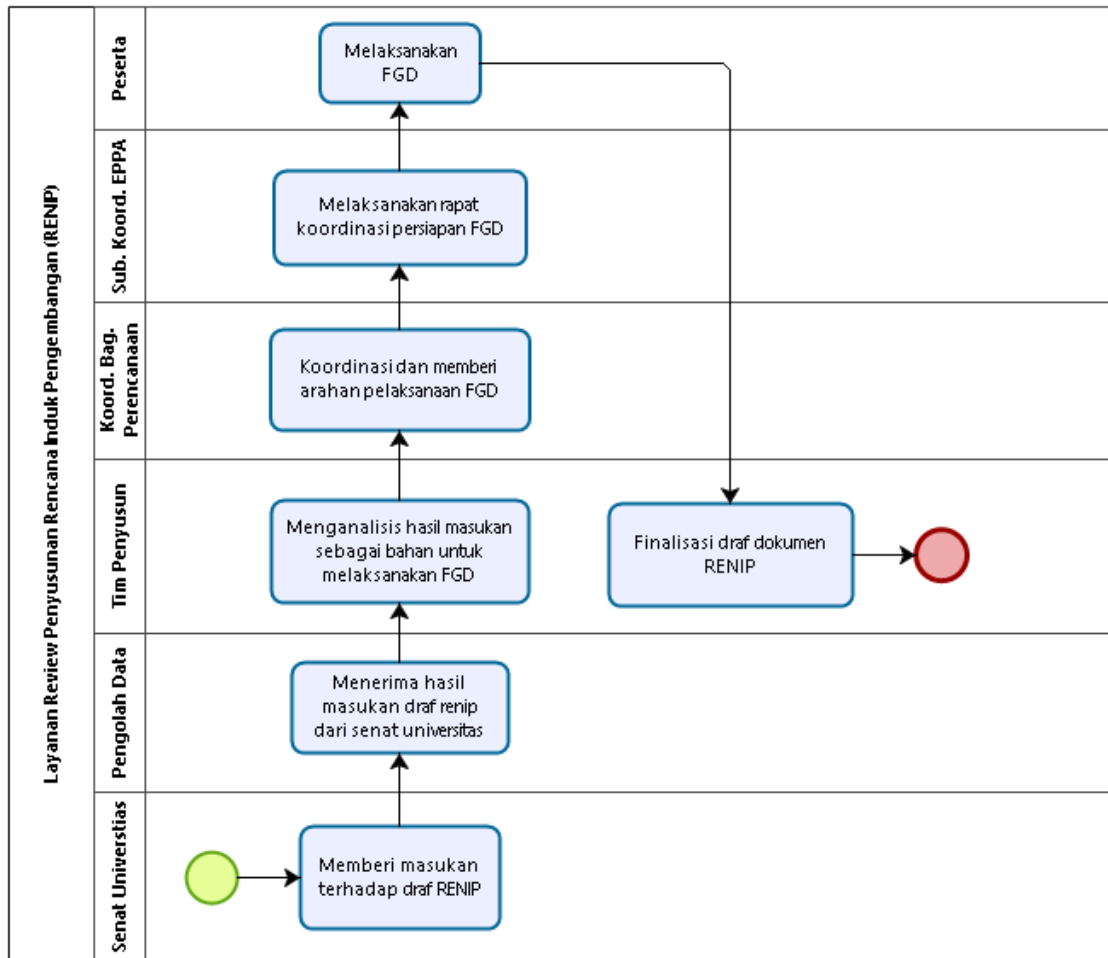

Level 4 Layanan Review Penyusunan RENSTRA

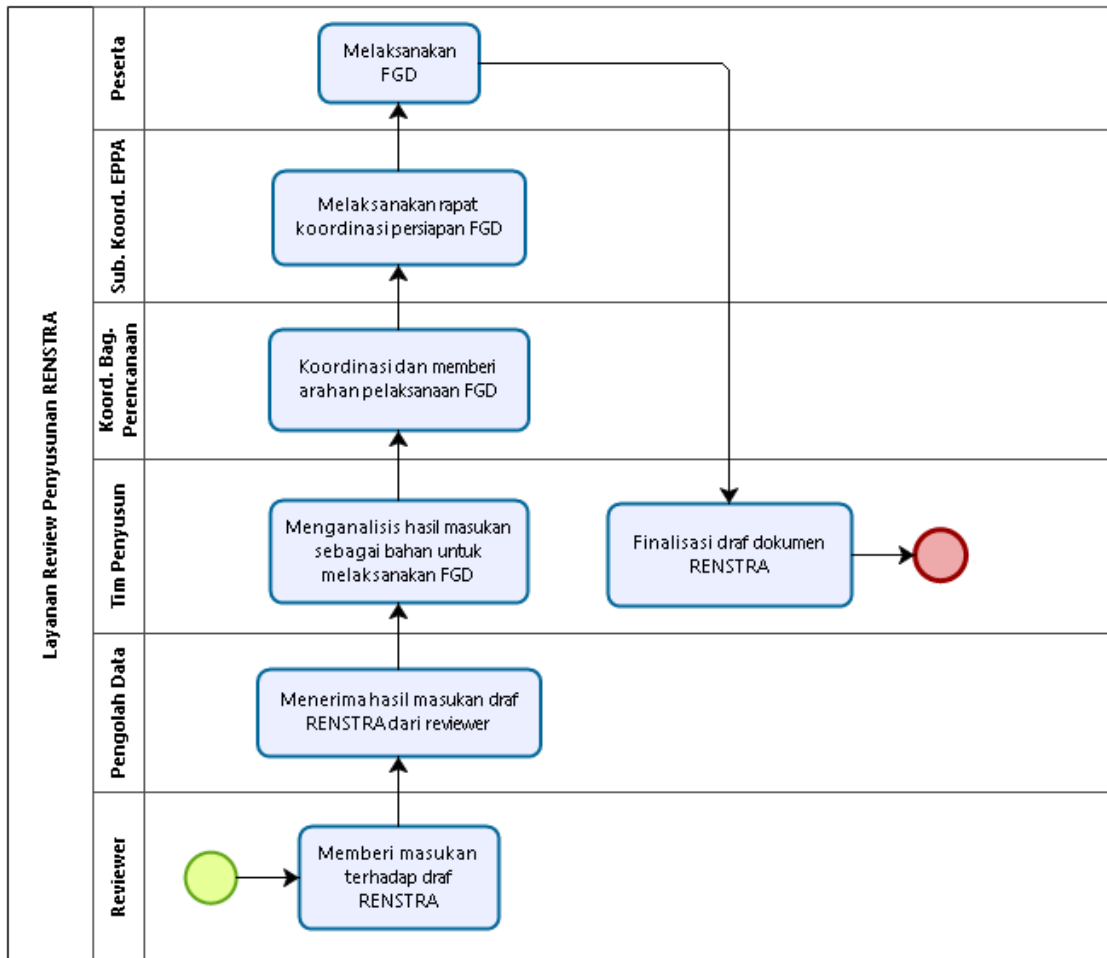

Level 4 Layanan Penyusunan RENOP

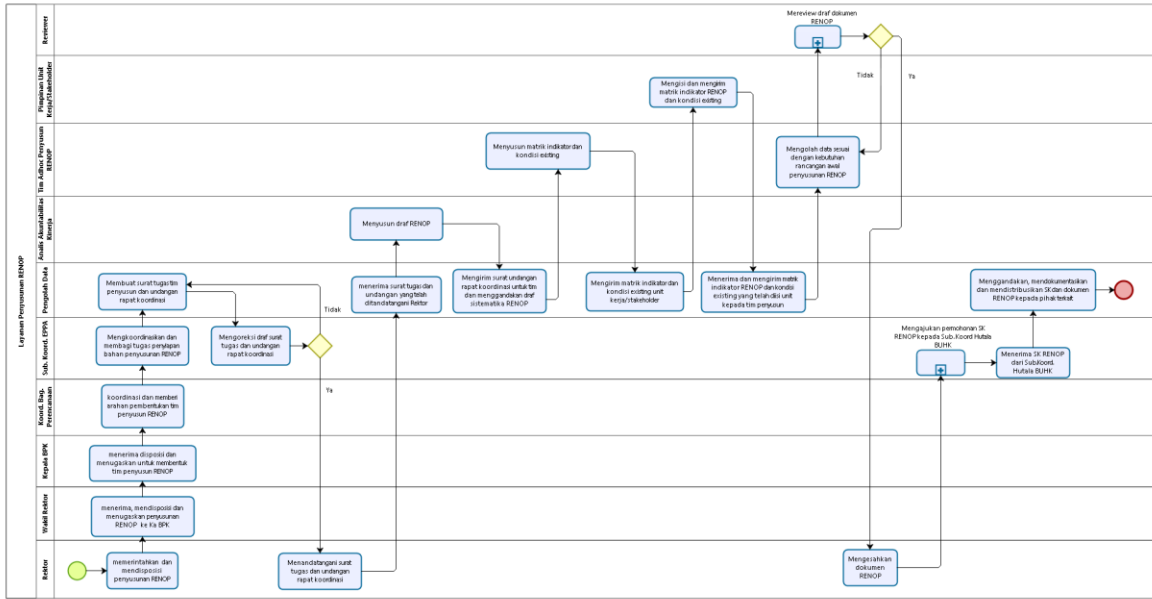

Level 4 Layanan Review Penyusunan RENOP

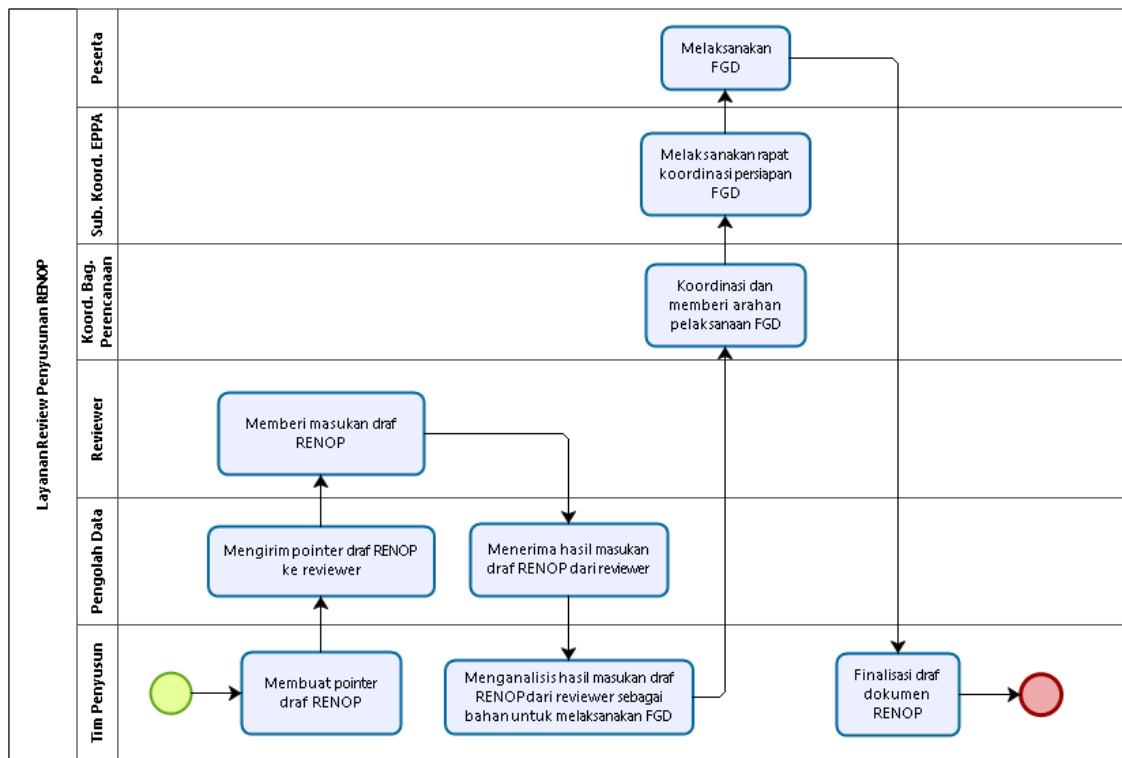

Level 4 Layanan Penyusunan Kontrak Kinerja

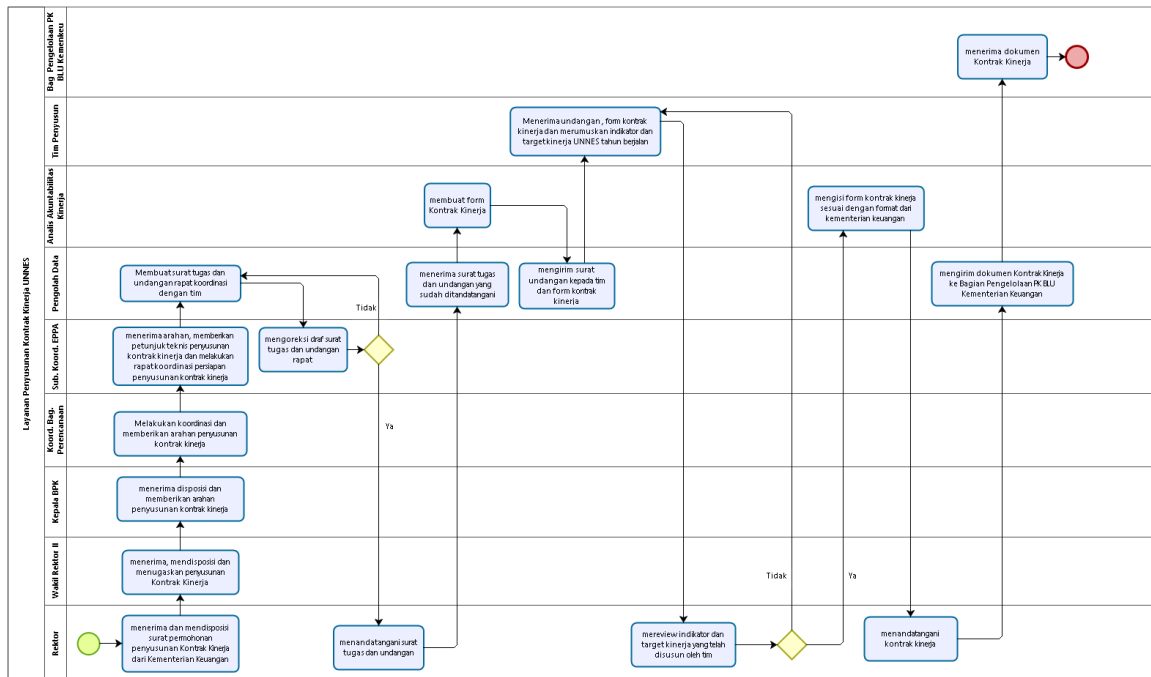

Level 4 Layanan Penyusunan PK Unit Kerja

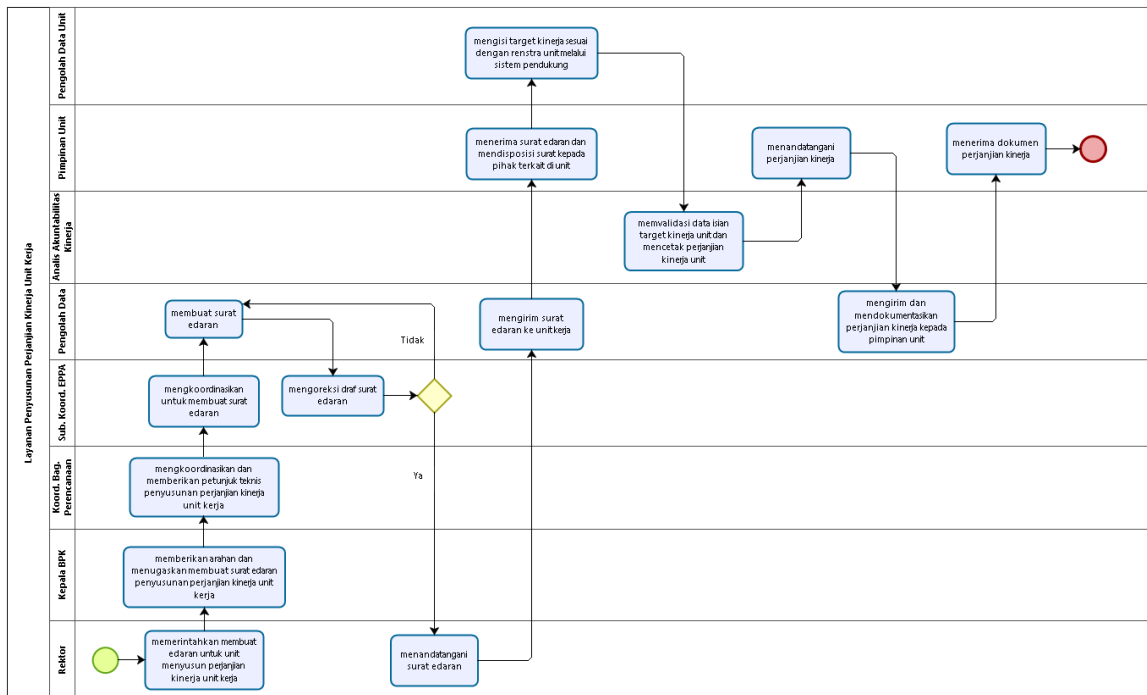

Level 4 Layanan Penyusunan PK dengan Kemendikbudristek

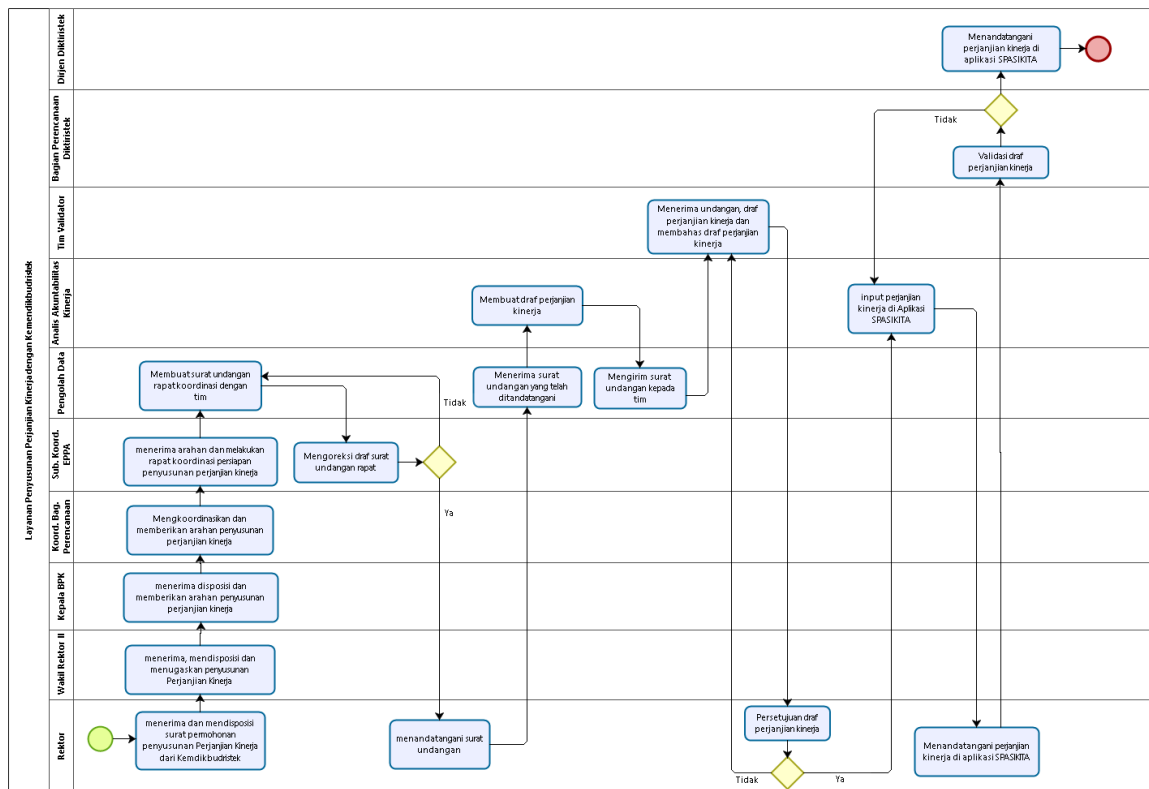

Level 4 Layanan Monev Kinerja Kegiatan dan Anggaran Unit Kerja

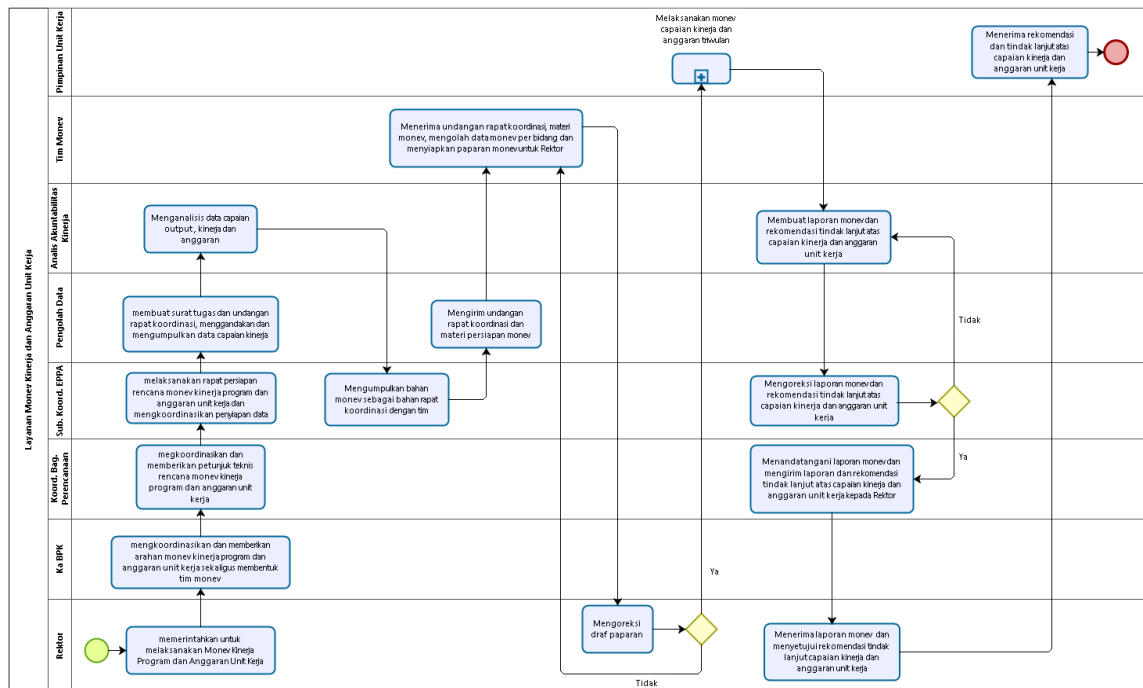

Level 4 Layanan Monev Capaian Kinerja dan Anggaran Triwulan

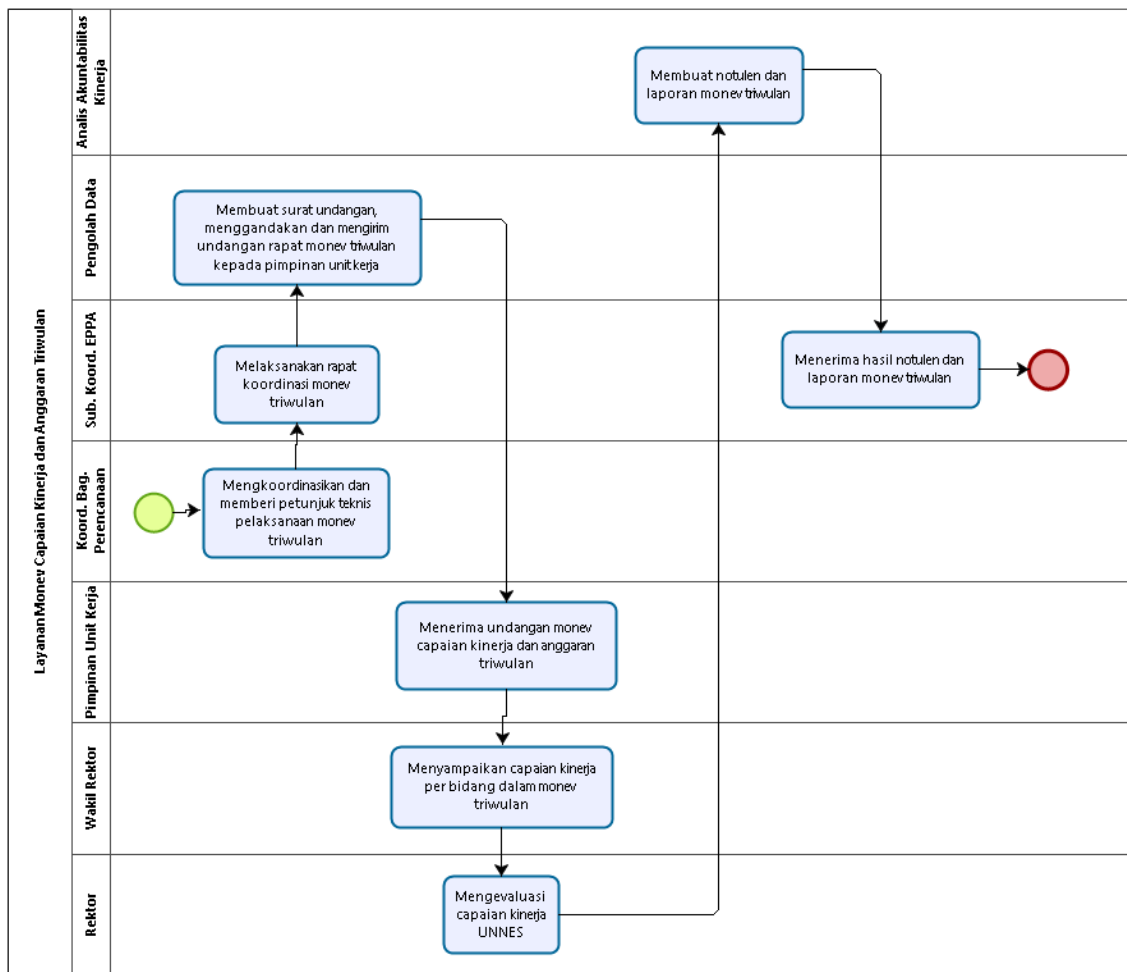

Level 4 Layanan Pengumpulan Data Kinerja

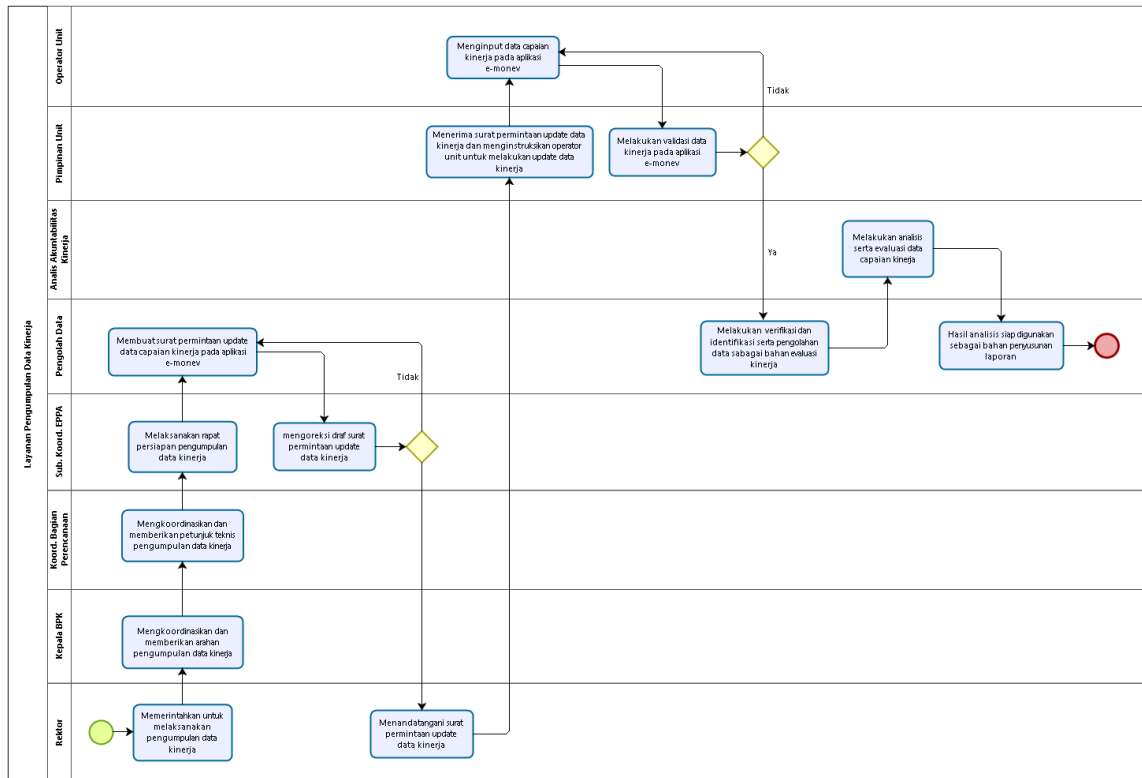

Level 4 Layanan Penyusunan Cascading PK

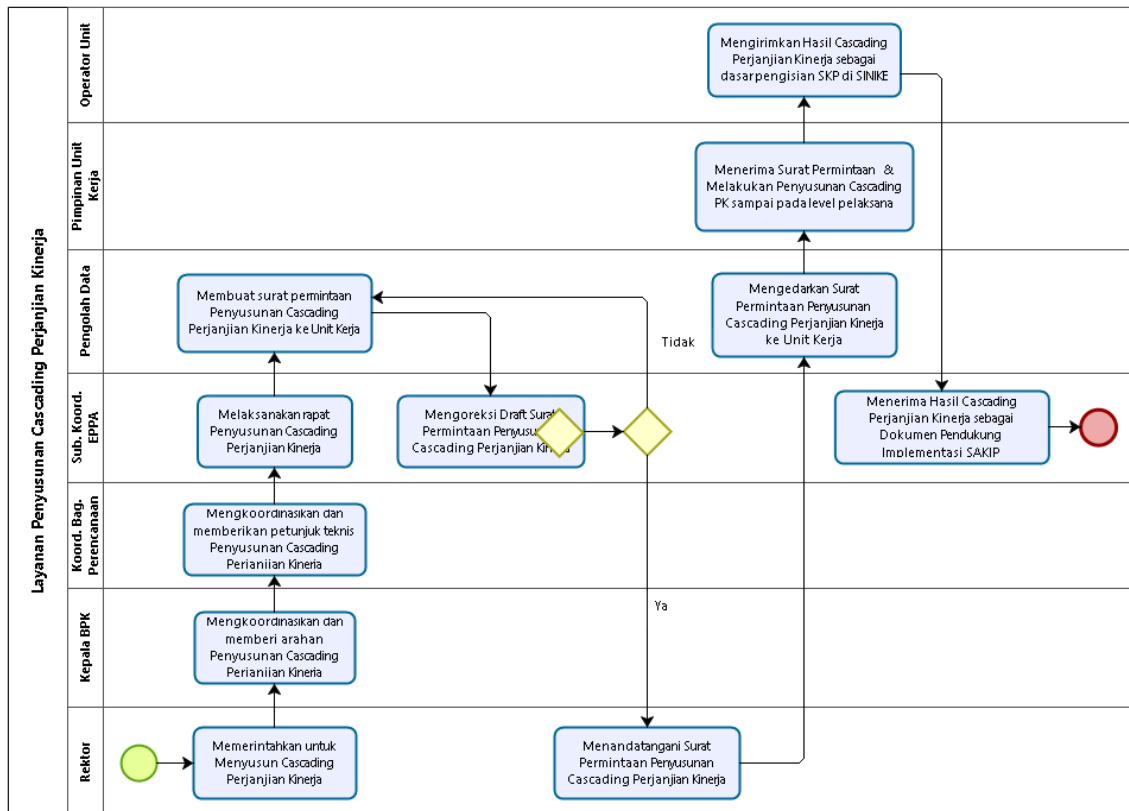

Level 4 Layanan Pengukuran Kinerja Triwulan

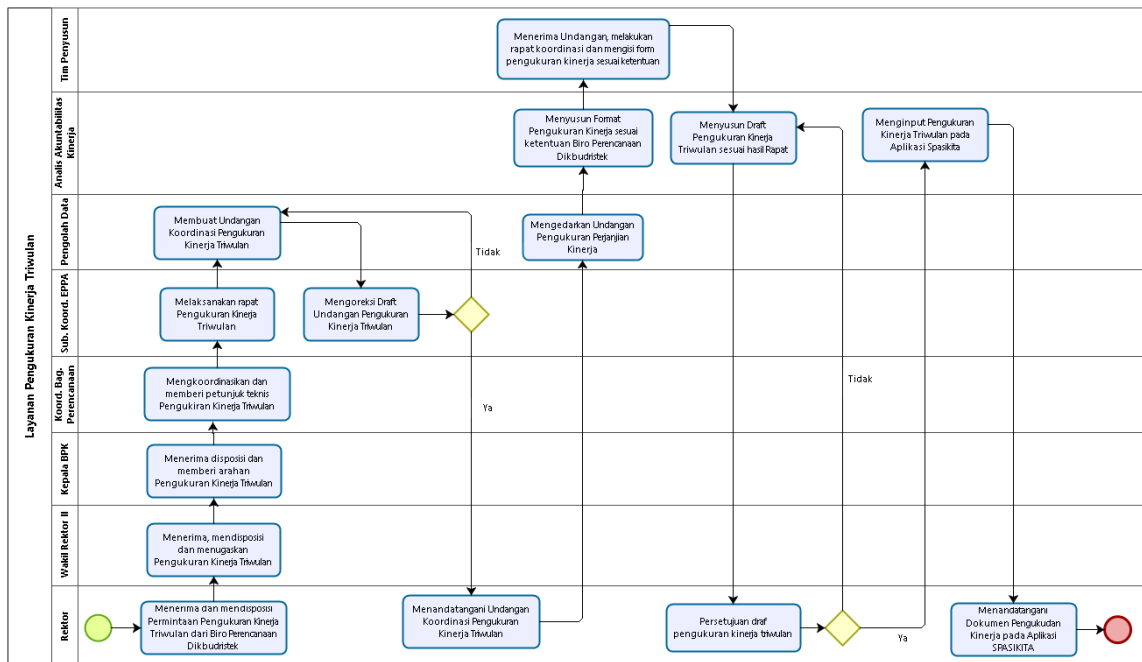

Level 4 Layanan Penyusunan Target RO dan Komponen SPASIKITA

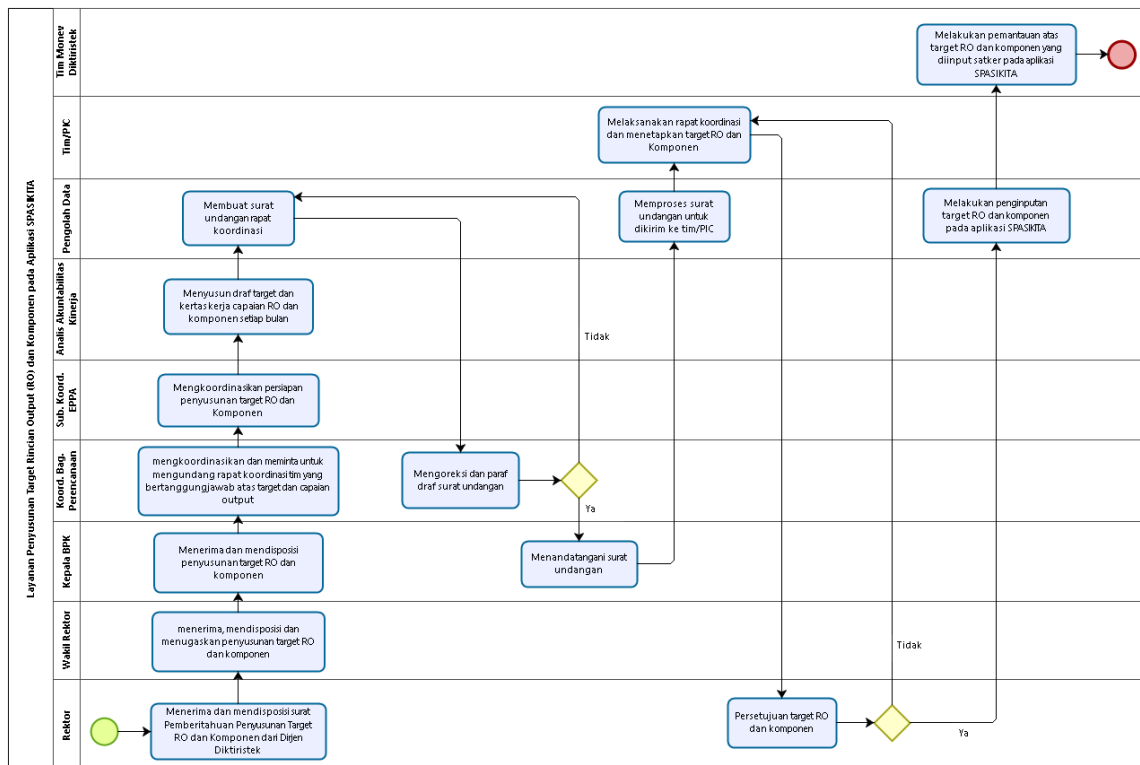

Level 4 Layanan Pelaporan Capaian RO dan Komponen pada Aplikasi SPASIKITA

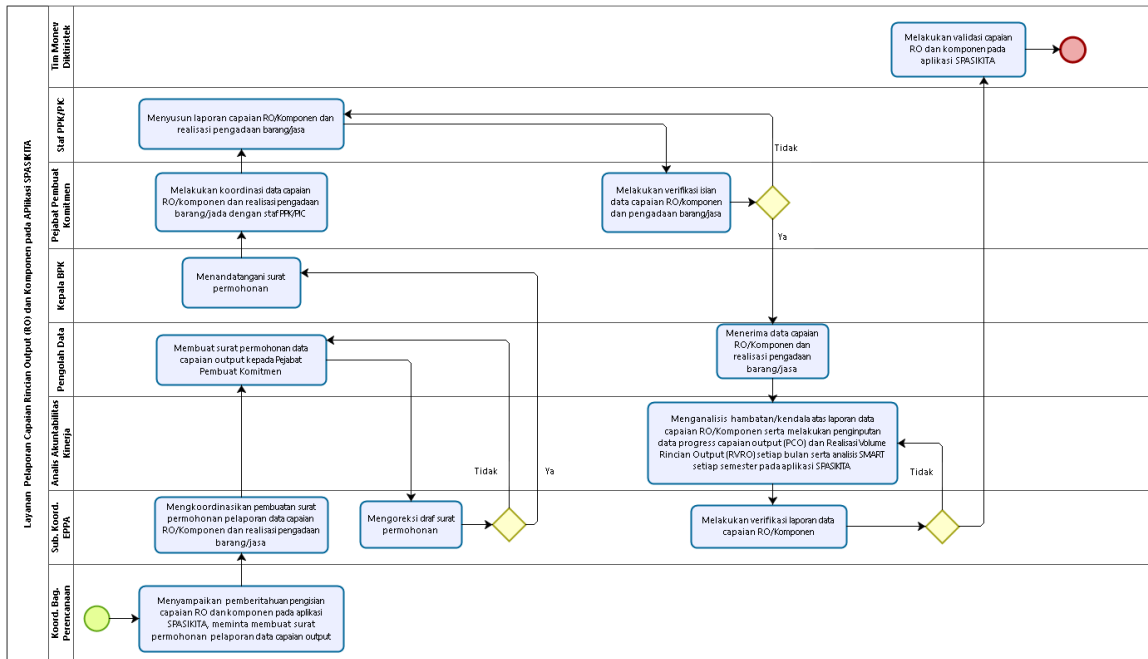

Powered by
bizagi
Module

Level 4 Layanan Penyusunan Evaluasi Mandiri SAKIP

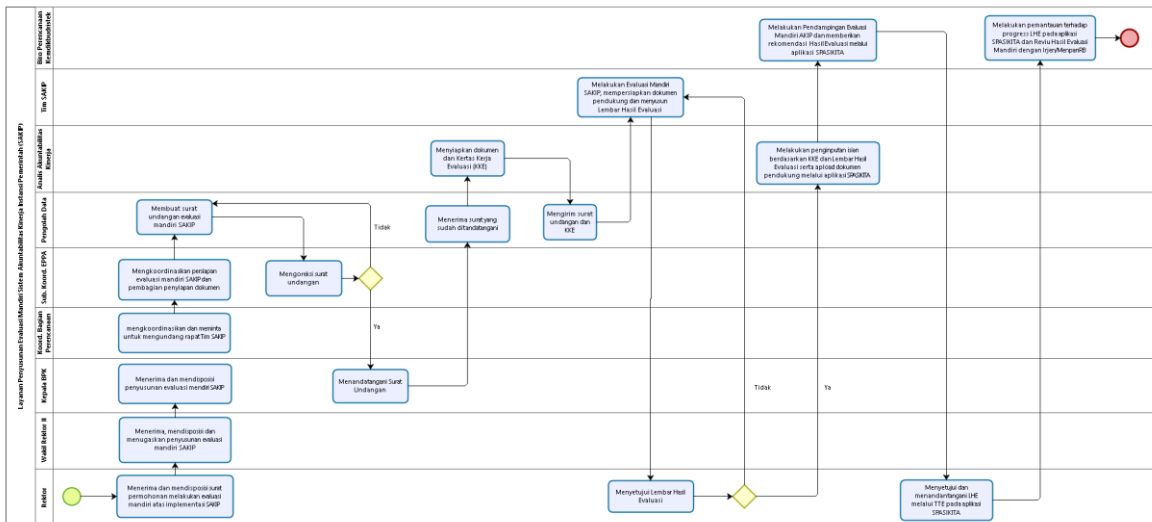

Powered by
bizagi
Module

Level 4 Layanan Penyusunan Tindak Lanjut LHE SAKIP

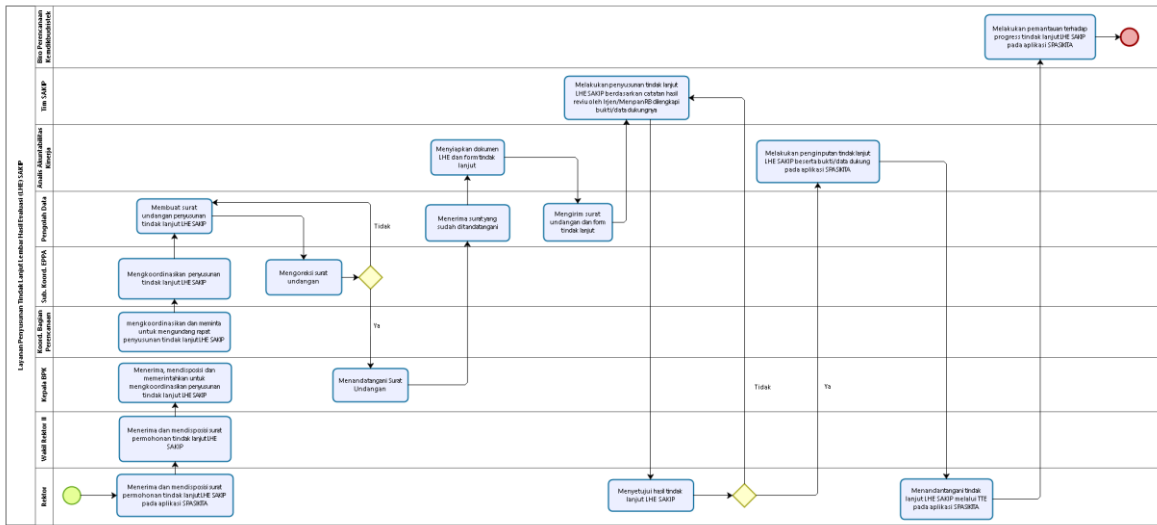

Level 3 Layanan PPA

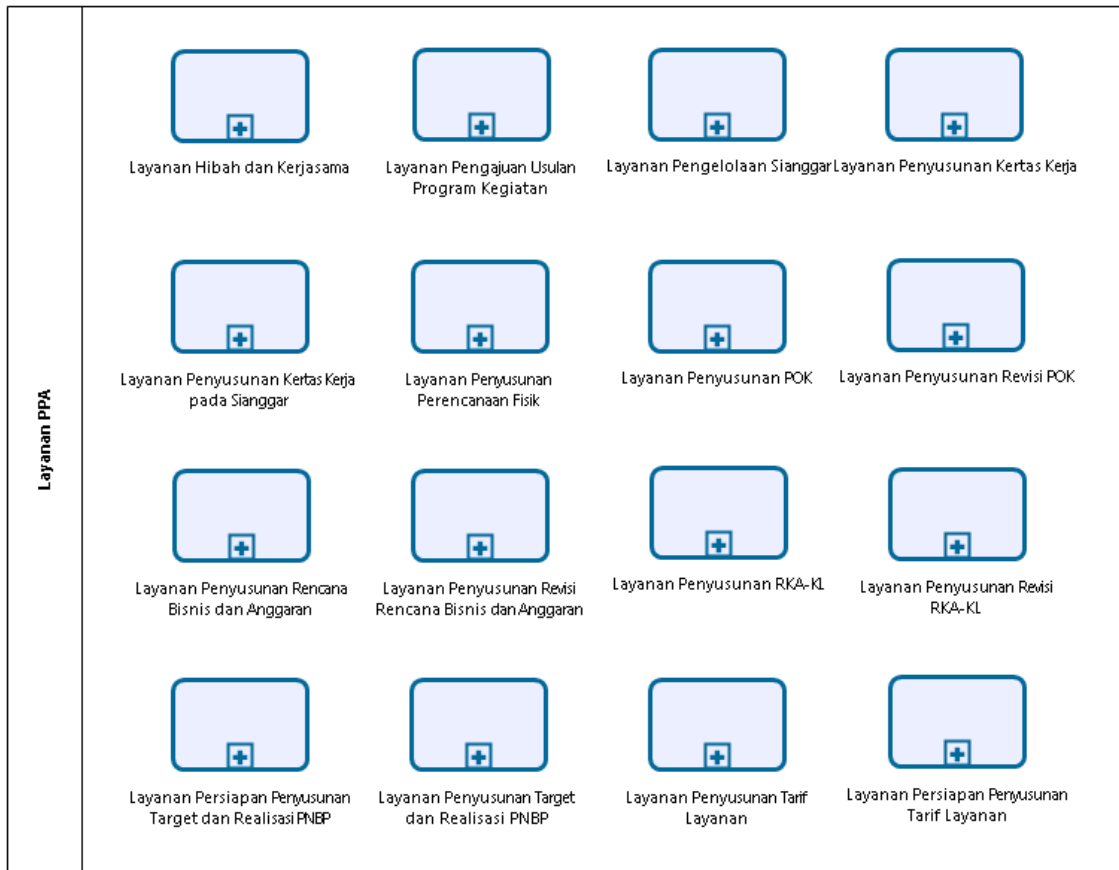

Level 4 Layanan Hibah dan Kerjasama

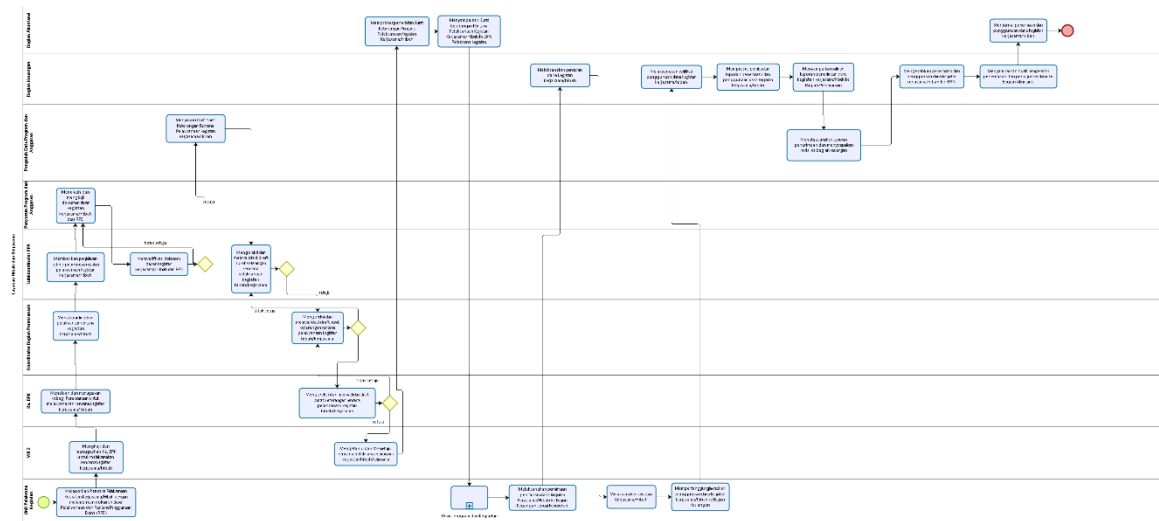

Level 4 Layanan Pengajuan Usul Program Kegiatan

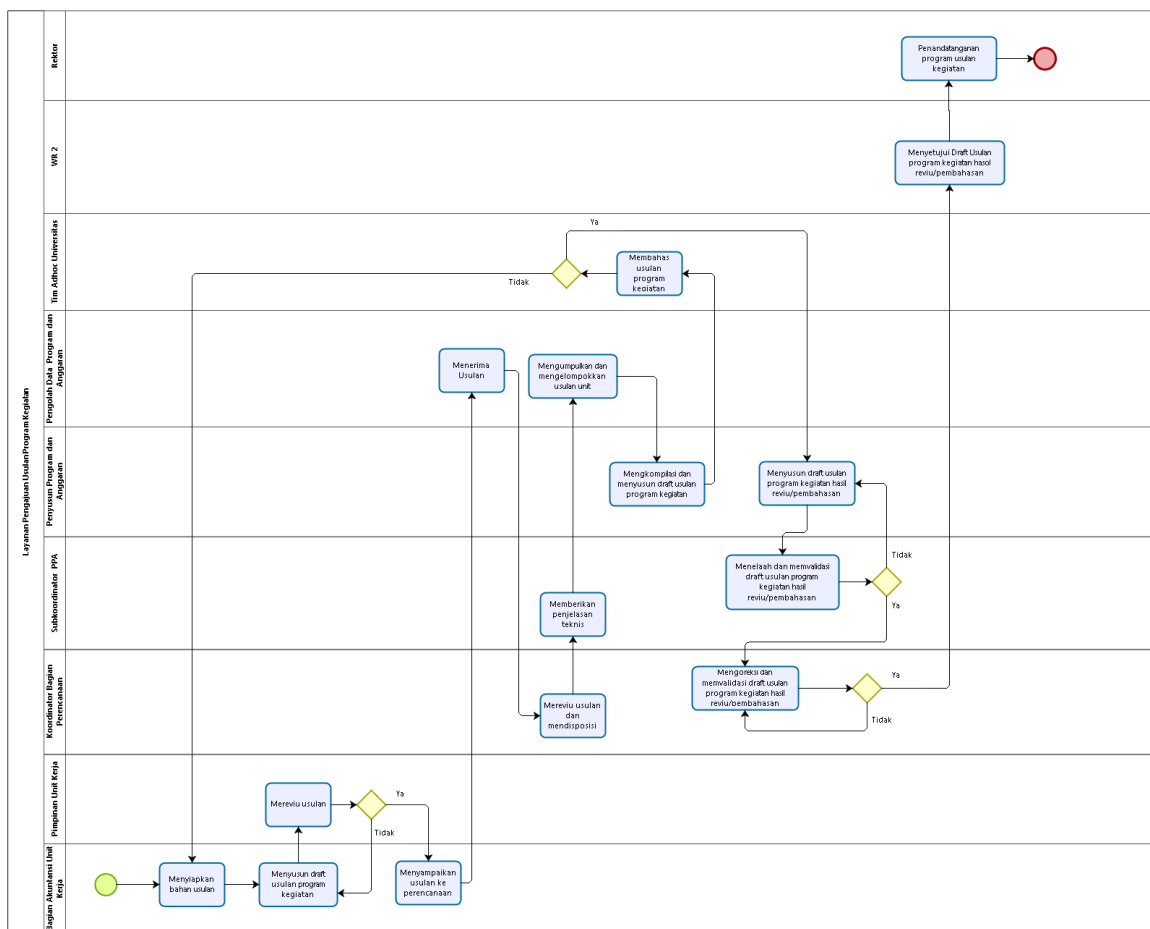

Level 4 Layanan Pengelolaan Sianggar

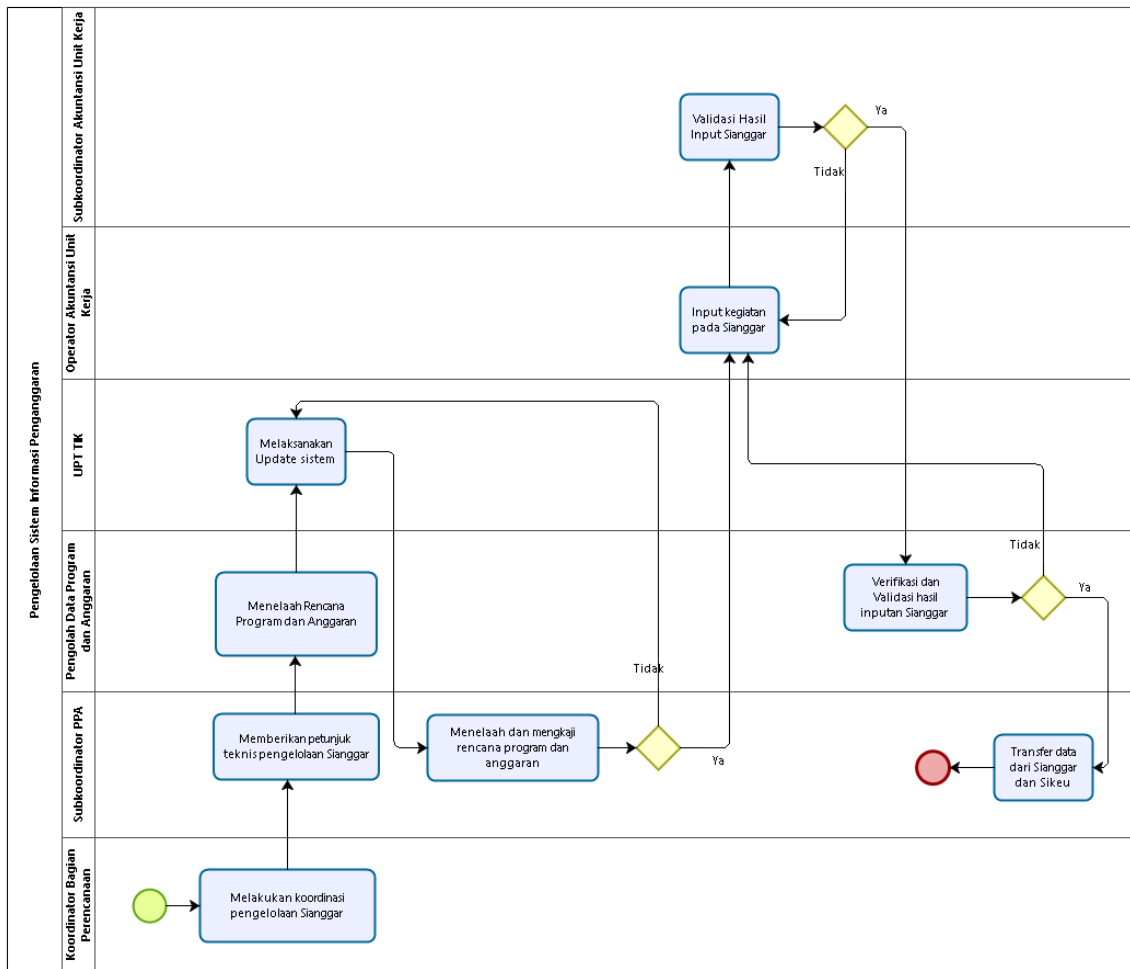

Level 4 Layanan Penyusunan Kertas Kerja pada Sianggar

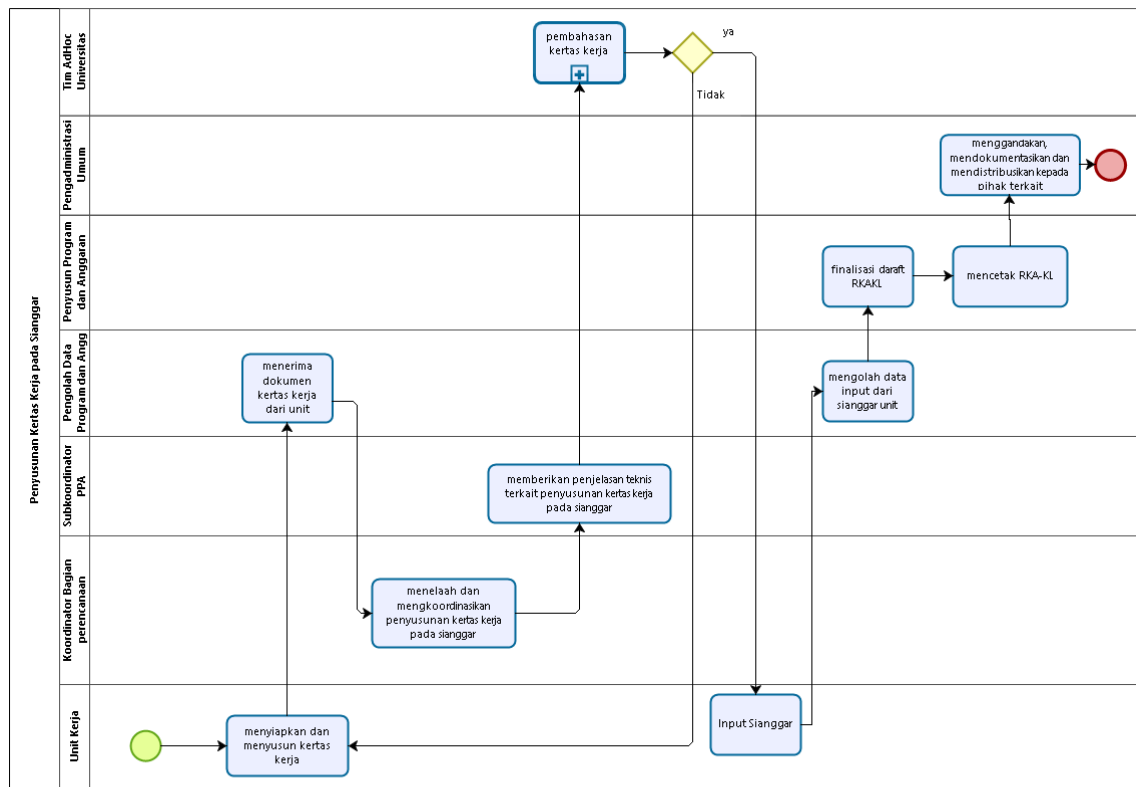

Level 4 Layanan Penyusunan Kertas Kerja

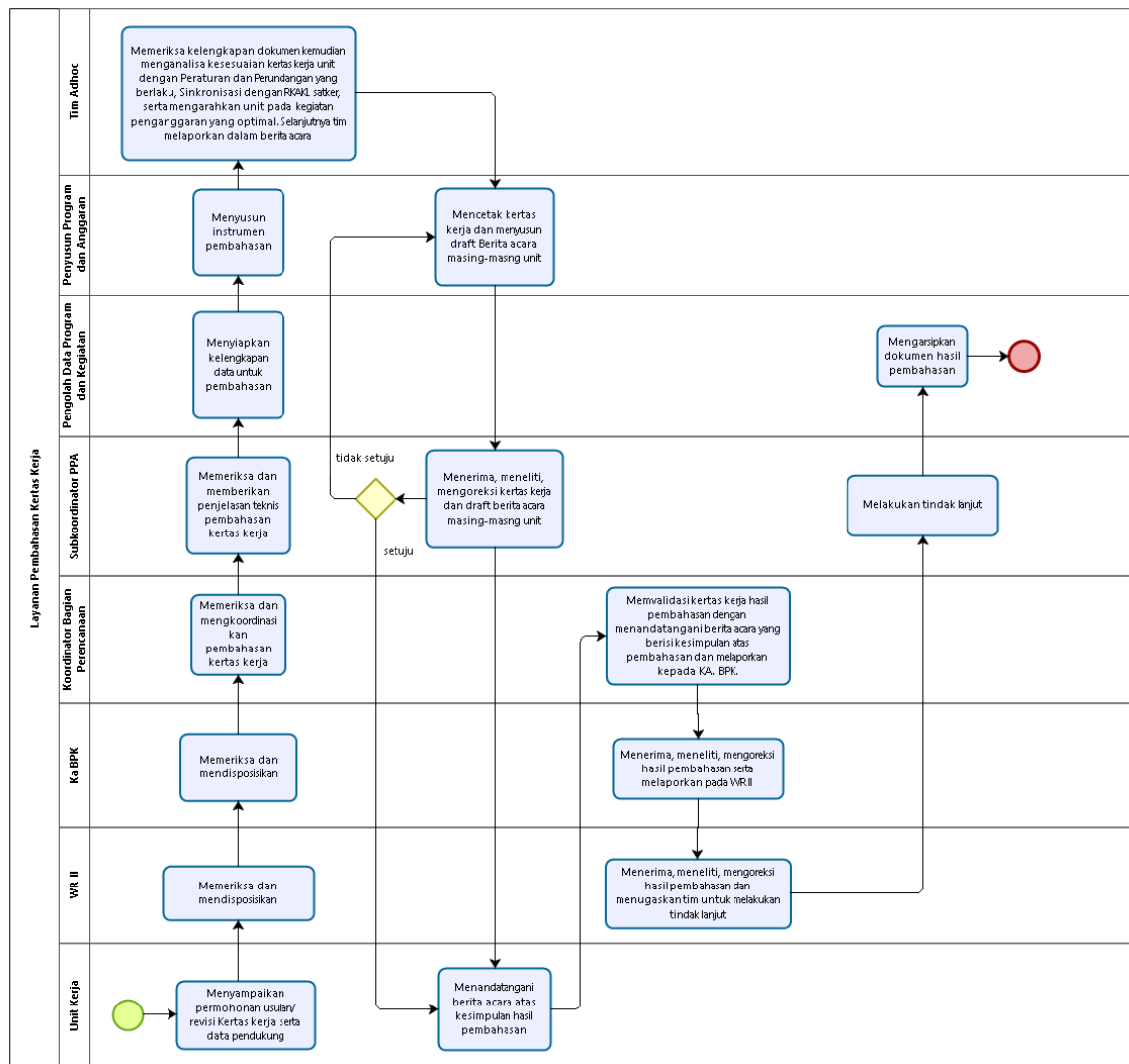

Level 4 Layanan Penyusunan Perencanaan Fisik

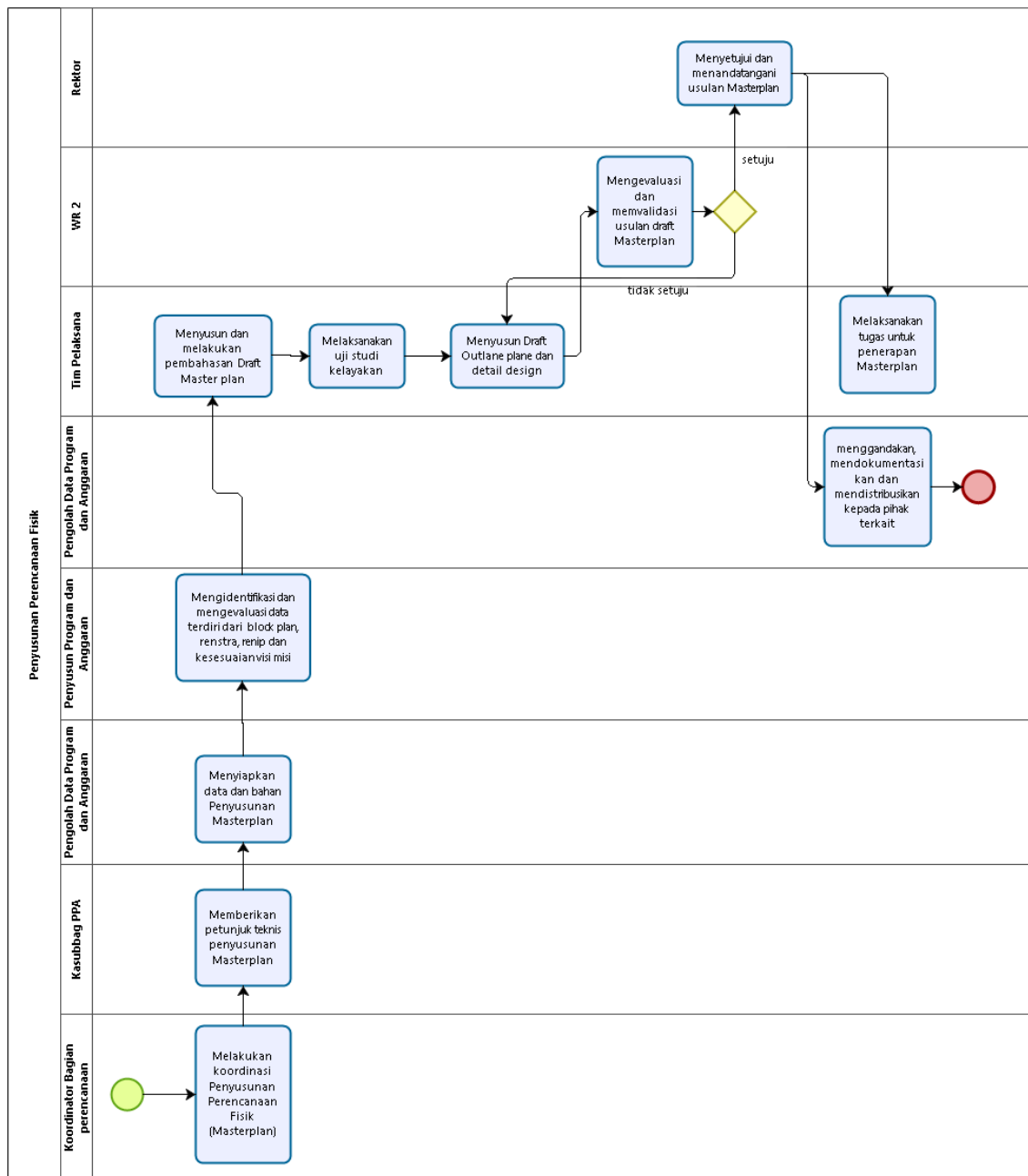

Level 4 Layanan Penyusunan POK

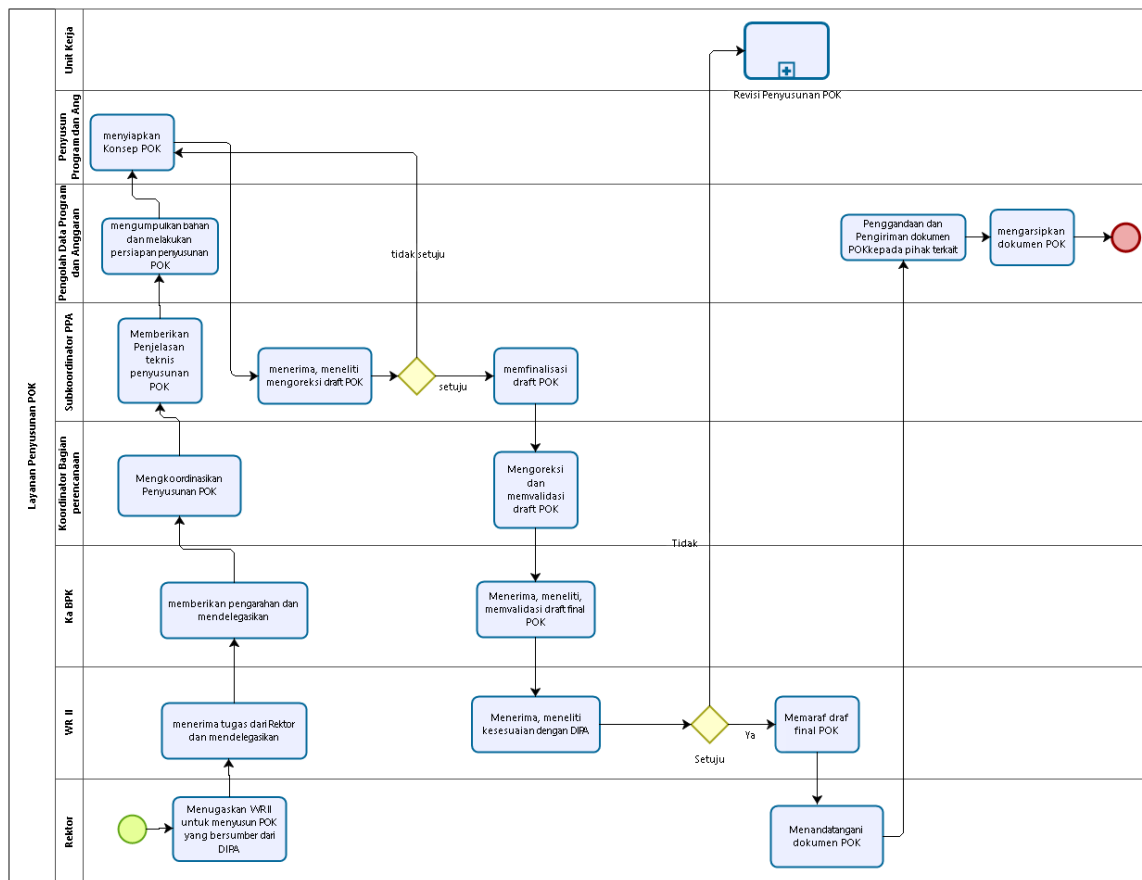

Level 4 Layanan Penyusunan Revisi POK

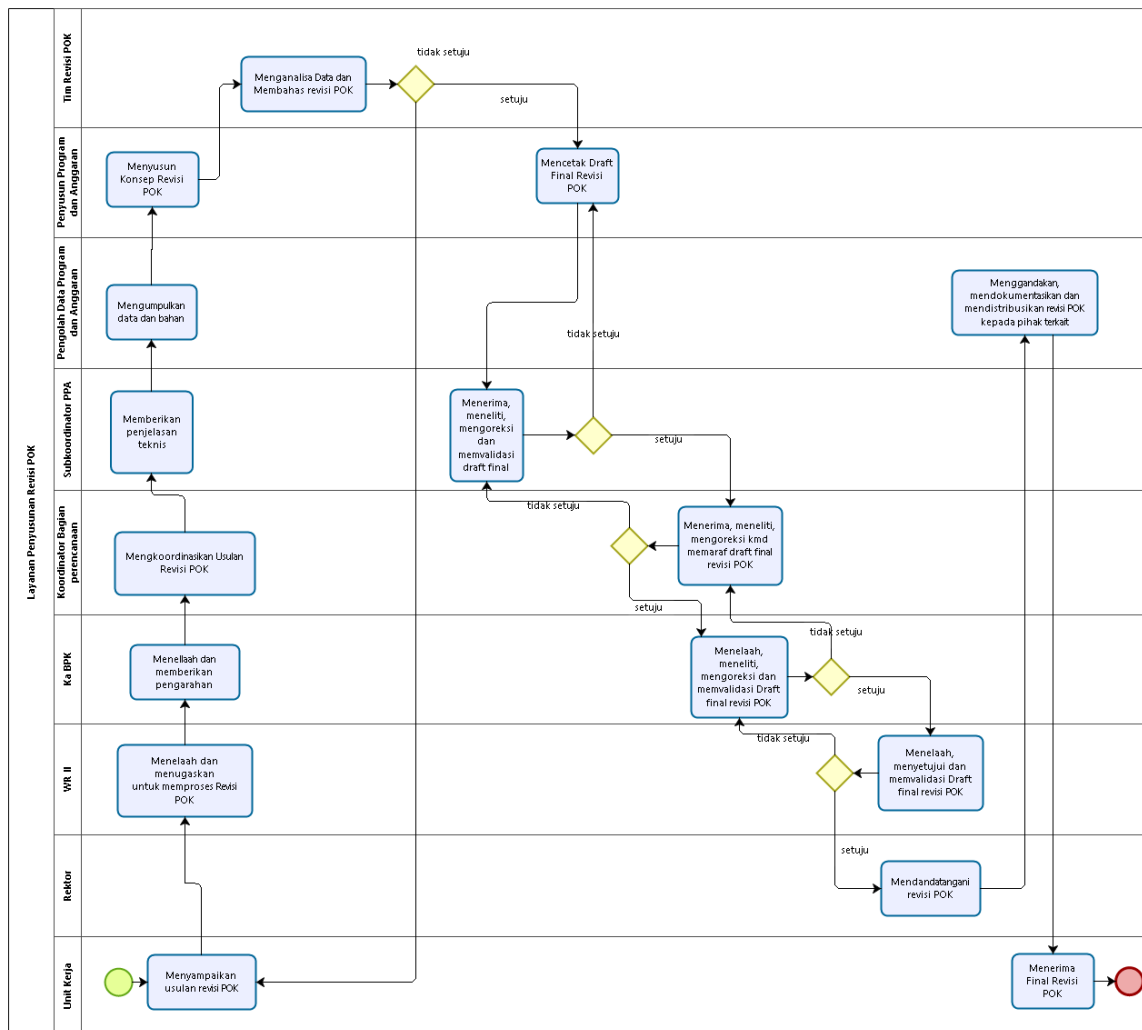

Level 4 Layanan Penyusunan Rencana Bisnis dan Anggaran

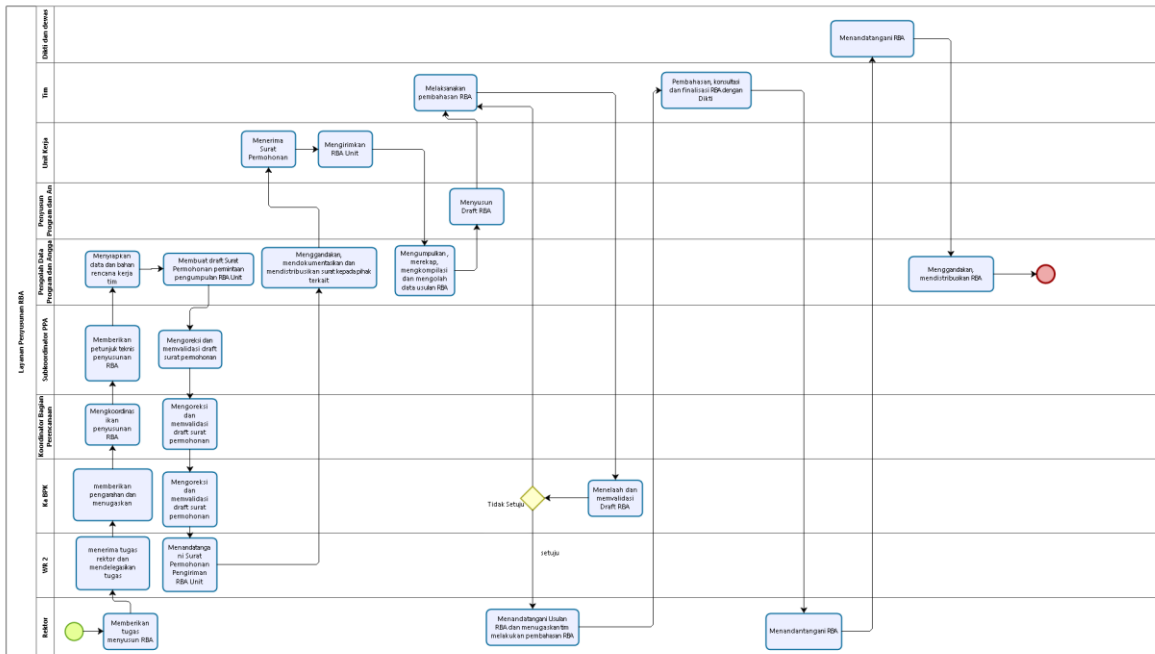

Level 4 Layanan Penyusunan Revisi Rencana Bisnis dan Anggaran

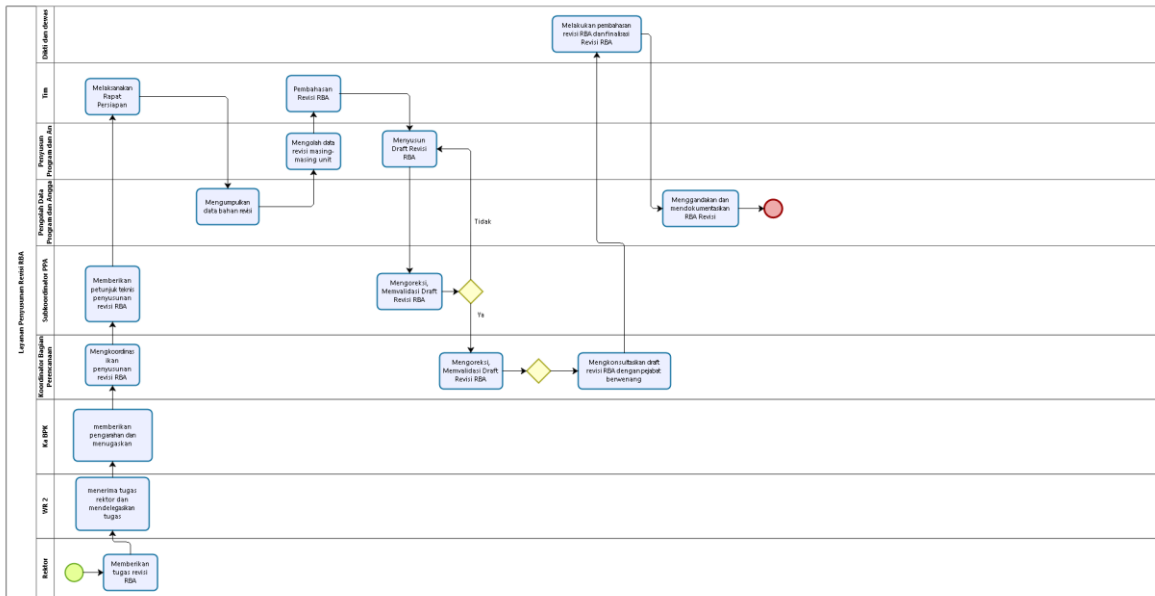

Level 4 Layanan Penyusunan RKA-KL

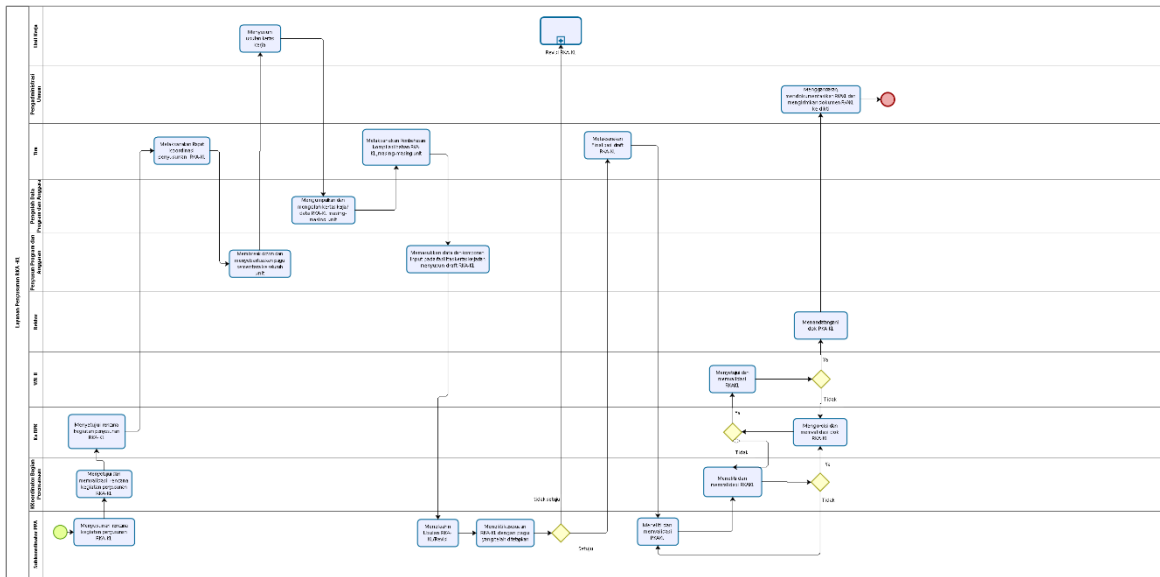

Level 4 Layanan Penyusunan Revisi RKA-KL

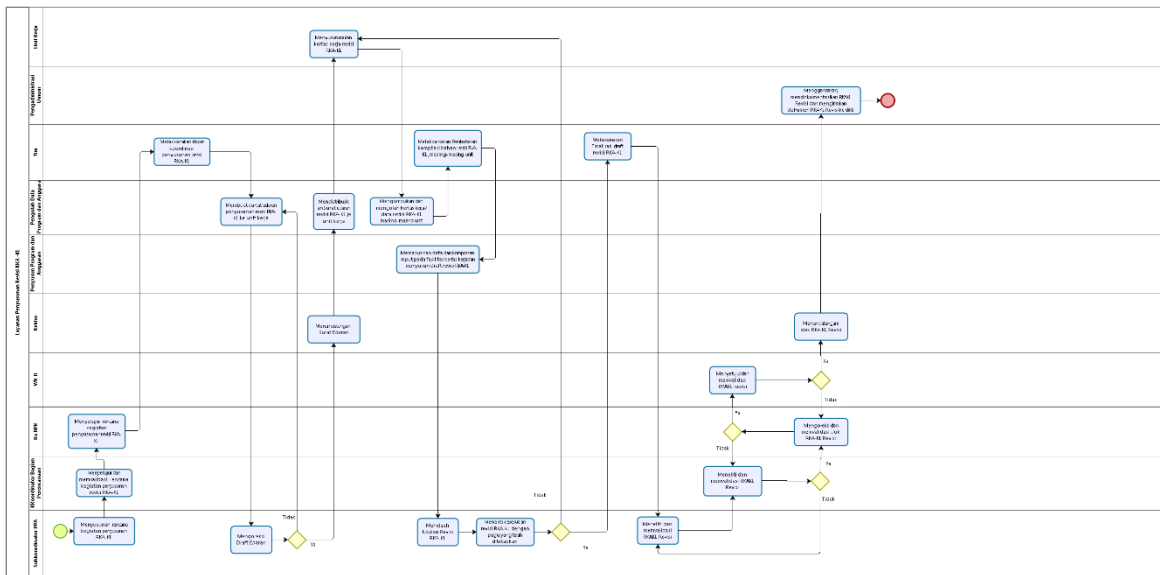

Level 4 Layanan Persiapan Penyusunan Target dan Realisasi PNBP

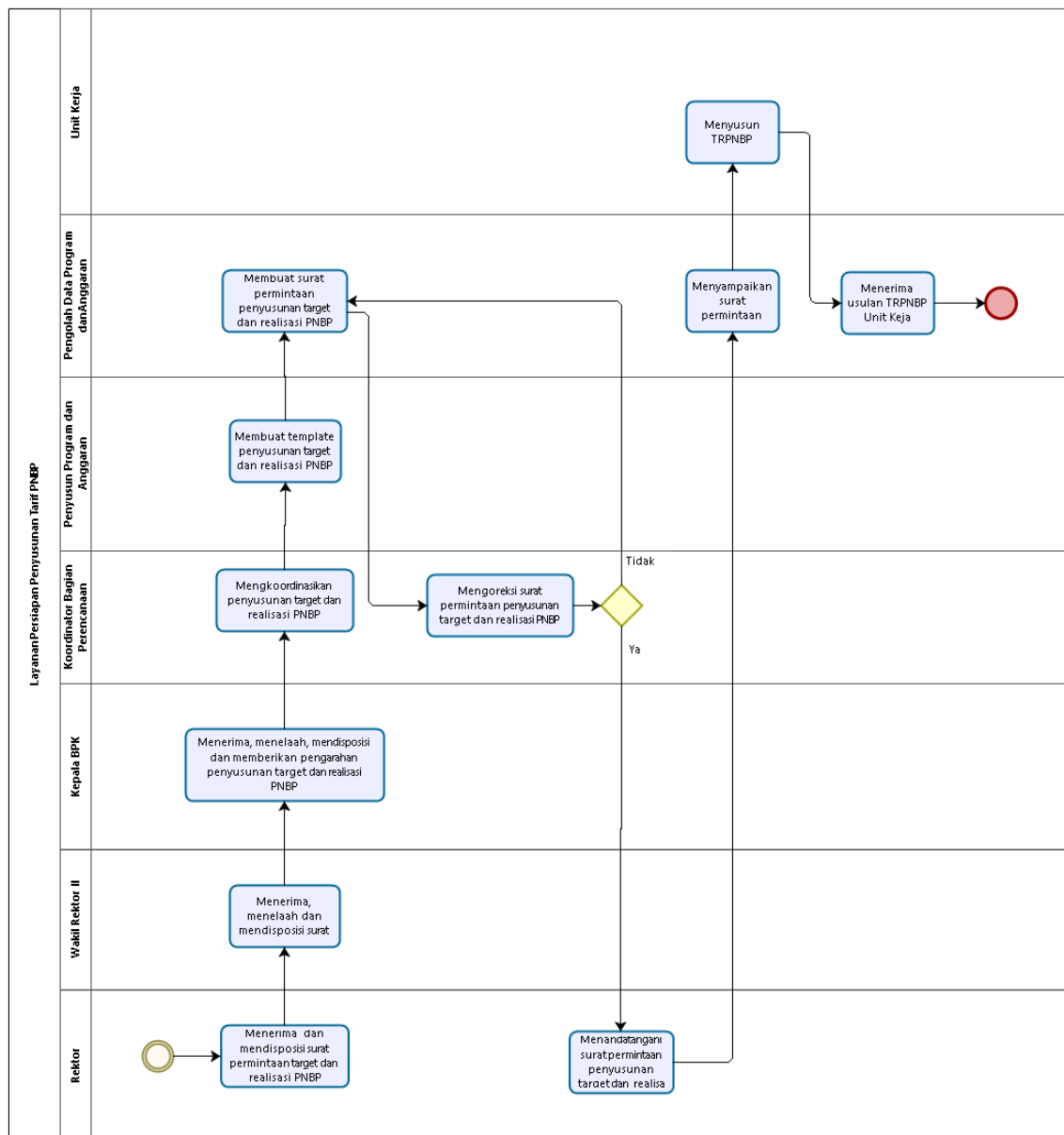

Level 4 Layanan Penyusunan Target dan Realisasi PNBP

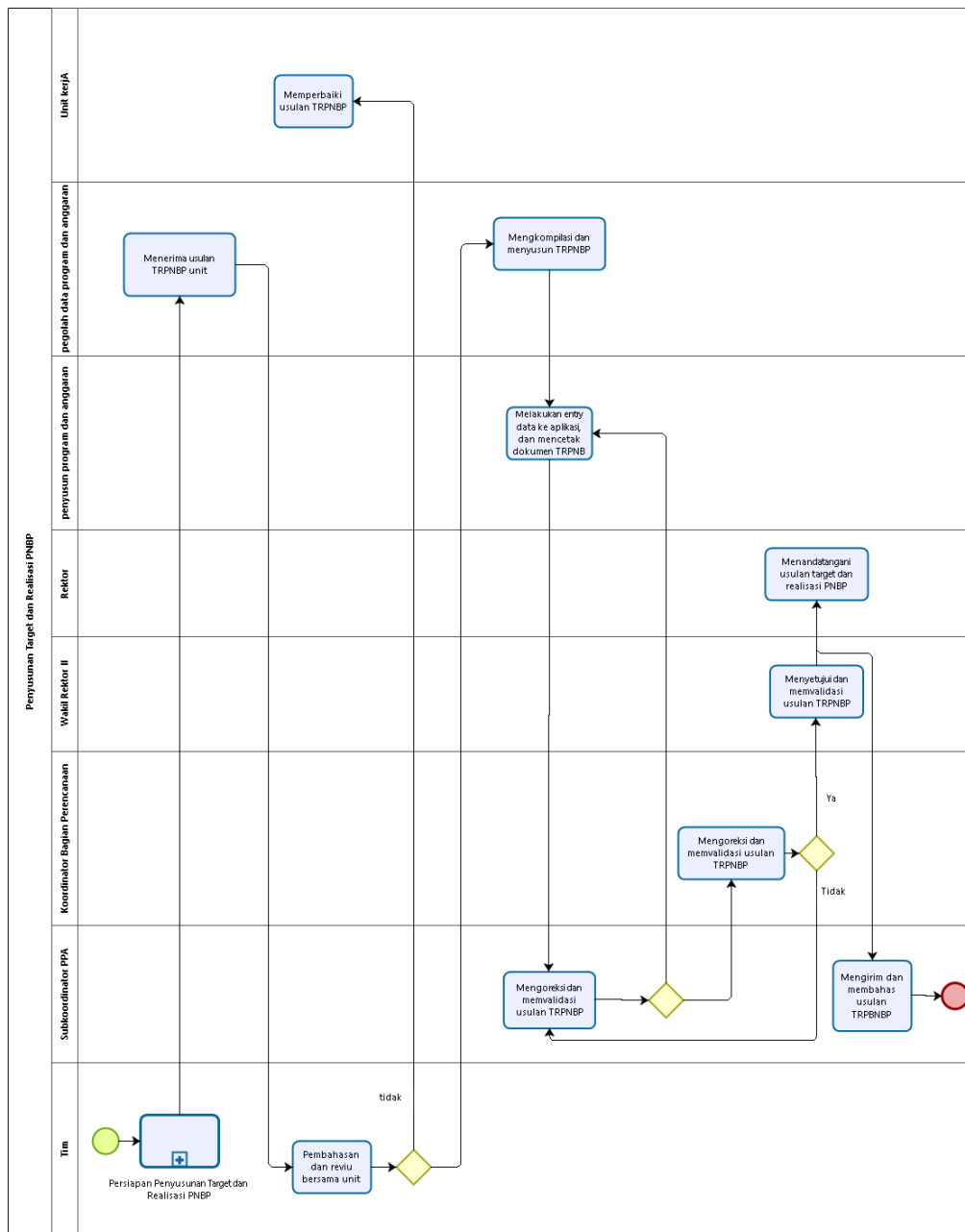

Ya

Powered by
bizagi
Modeler

Level 4 Layanan Penyusunan Tarif Layanan

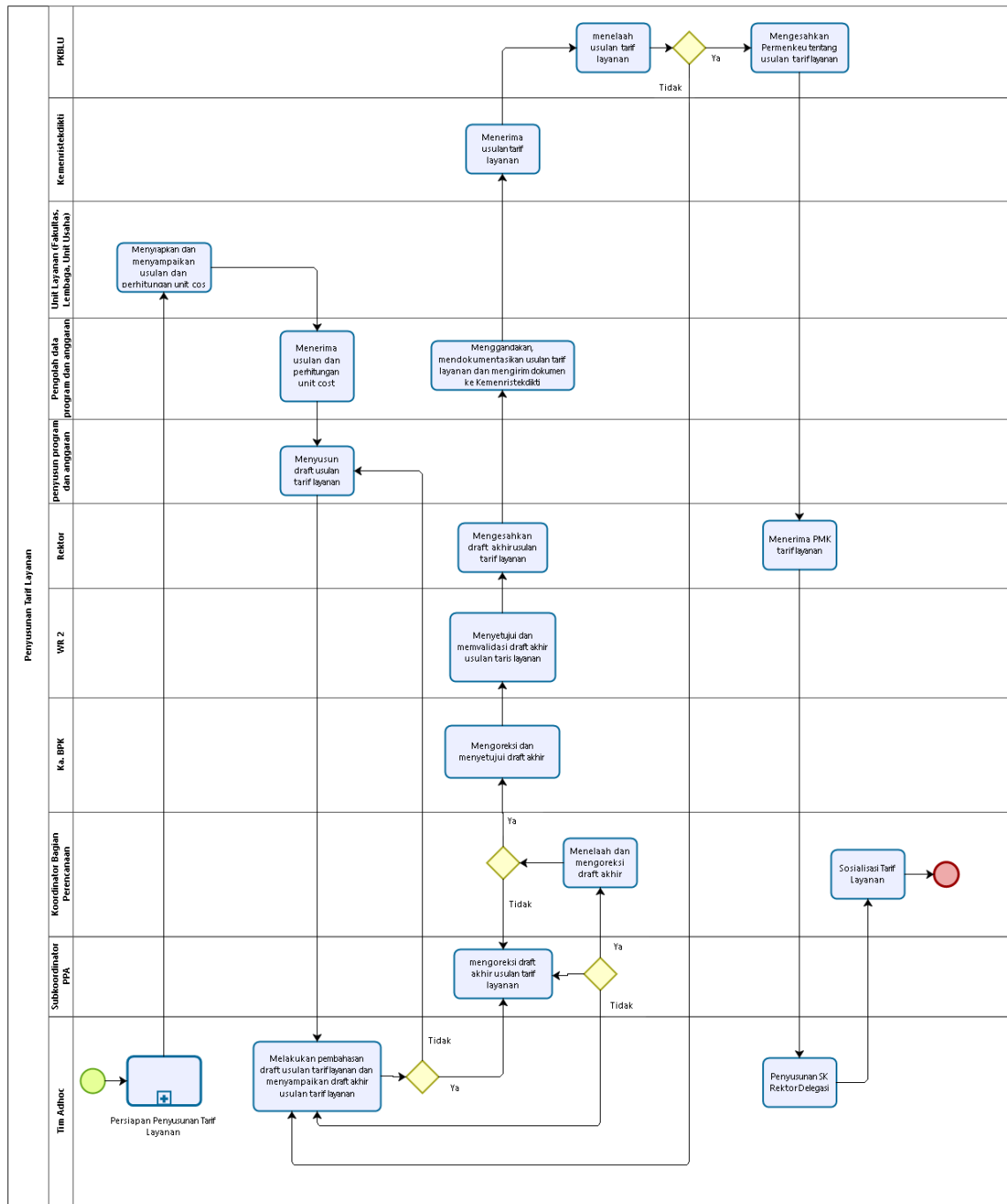

Level 4 Layanan Persiapan Penyusunan Tarif Layanan

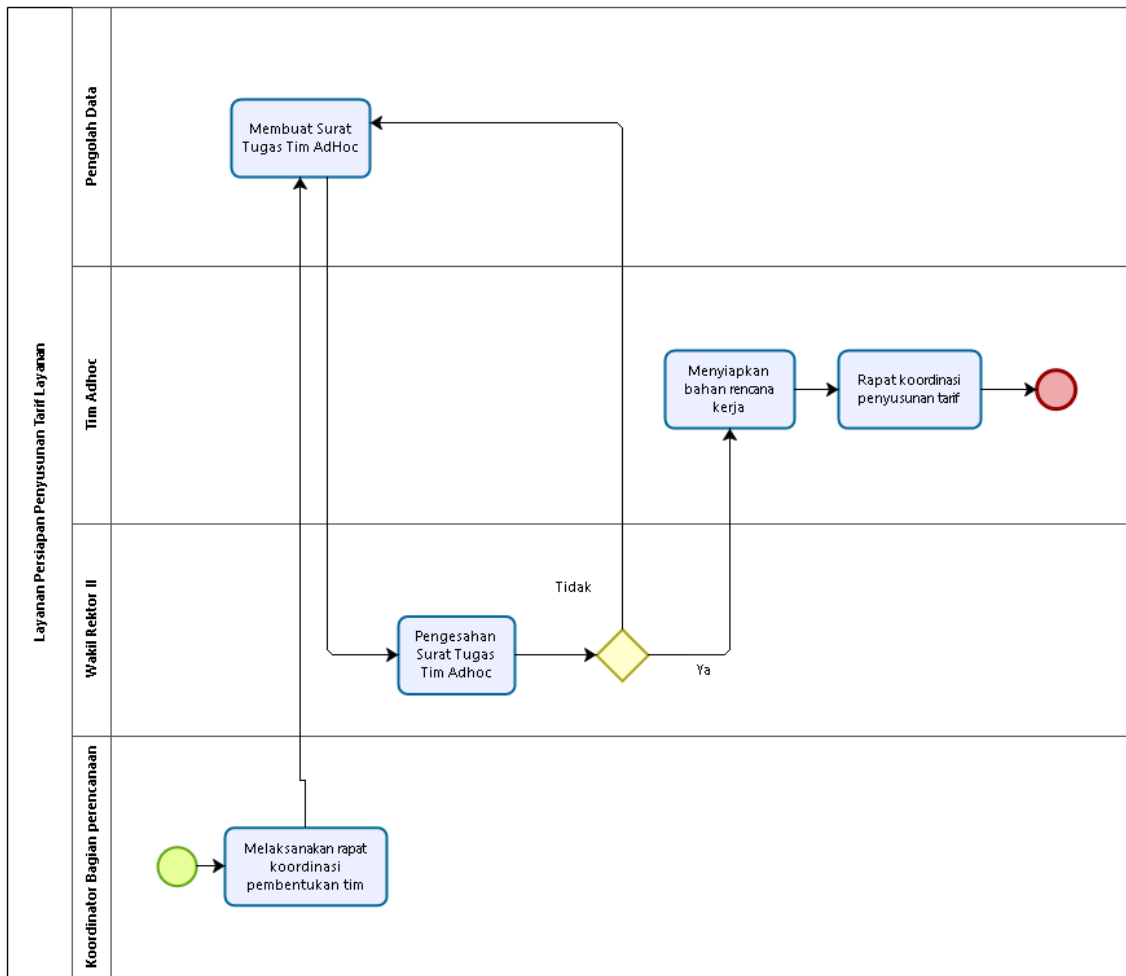

Level 2 Layanan Keuangan

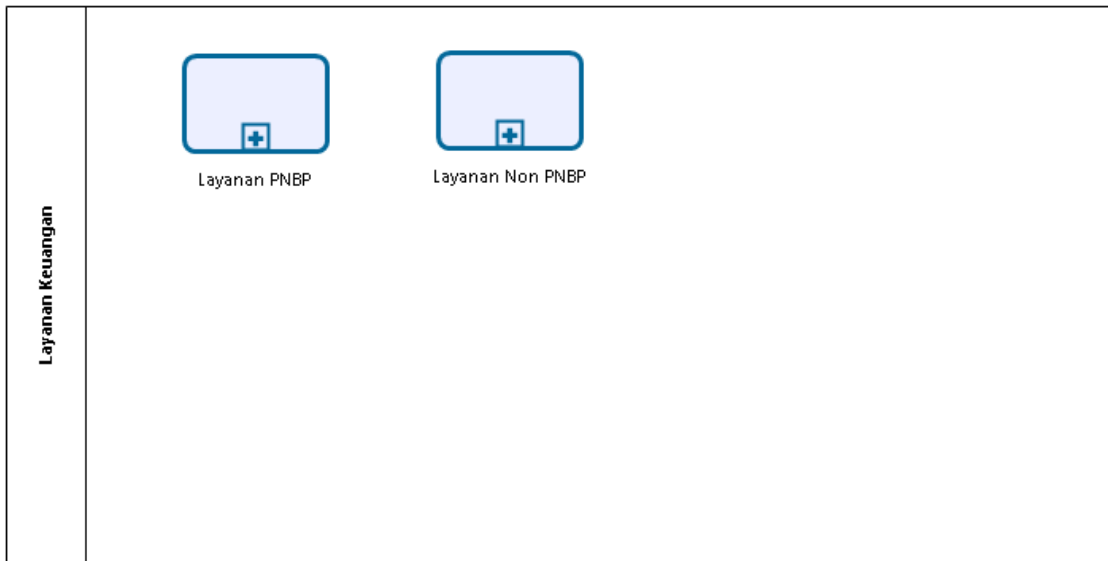

Level 3 Layanan PNBP

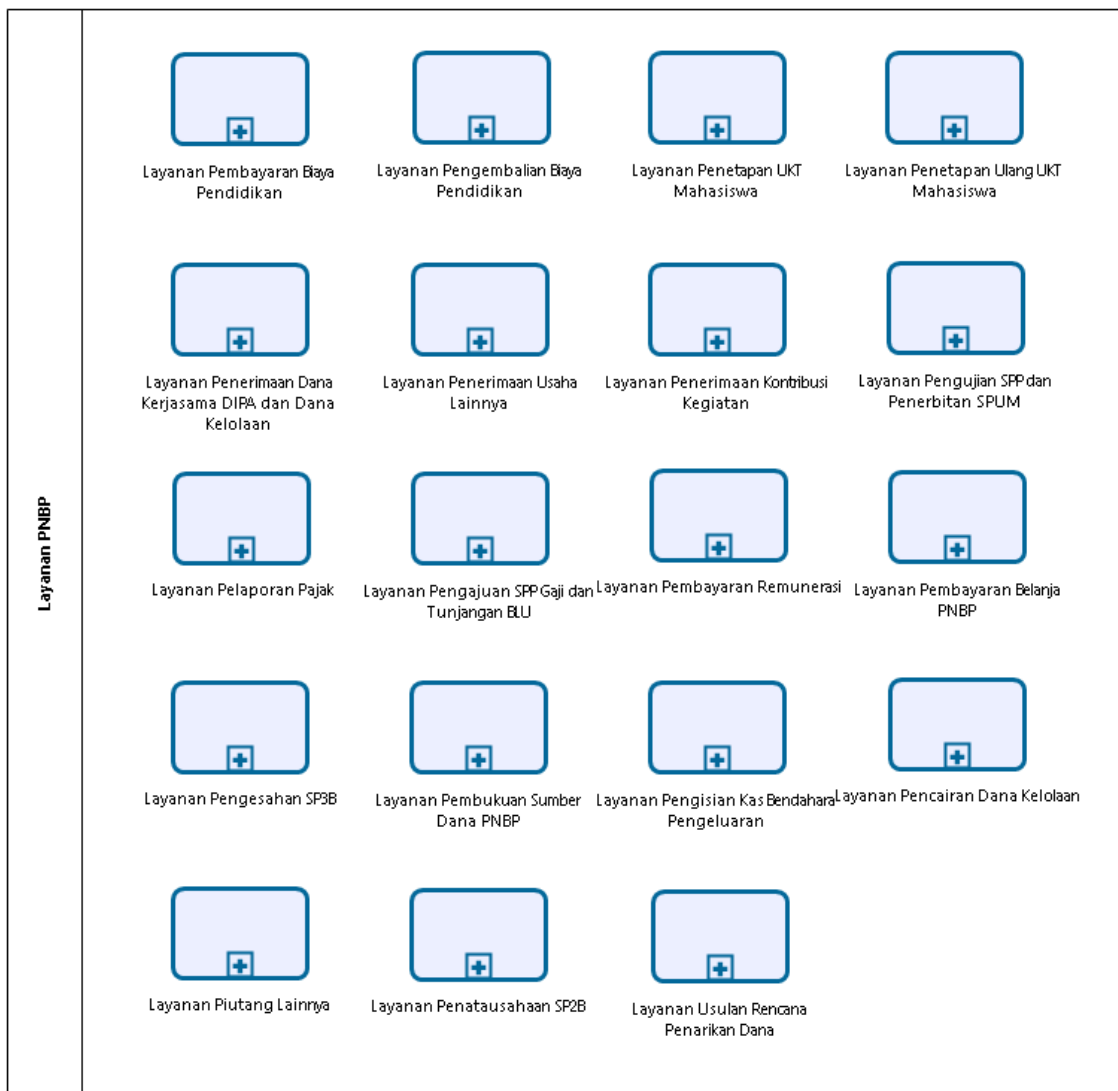

Level 4 Layanan Pembayaran Biaya Pendidikan

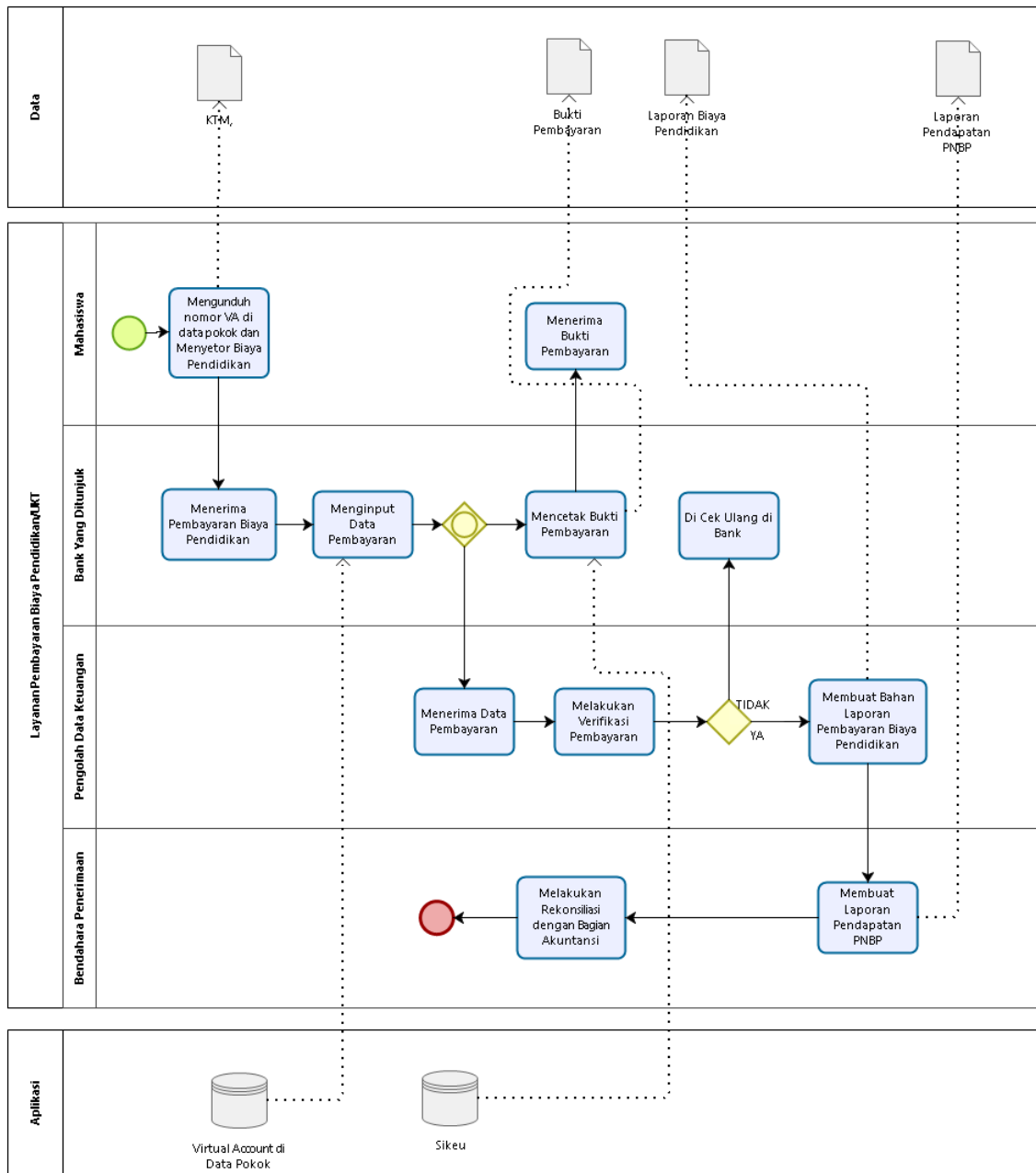

Level 4 Layanan Pengembalian Biaya Pendidikan

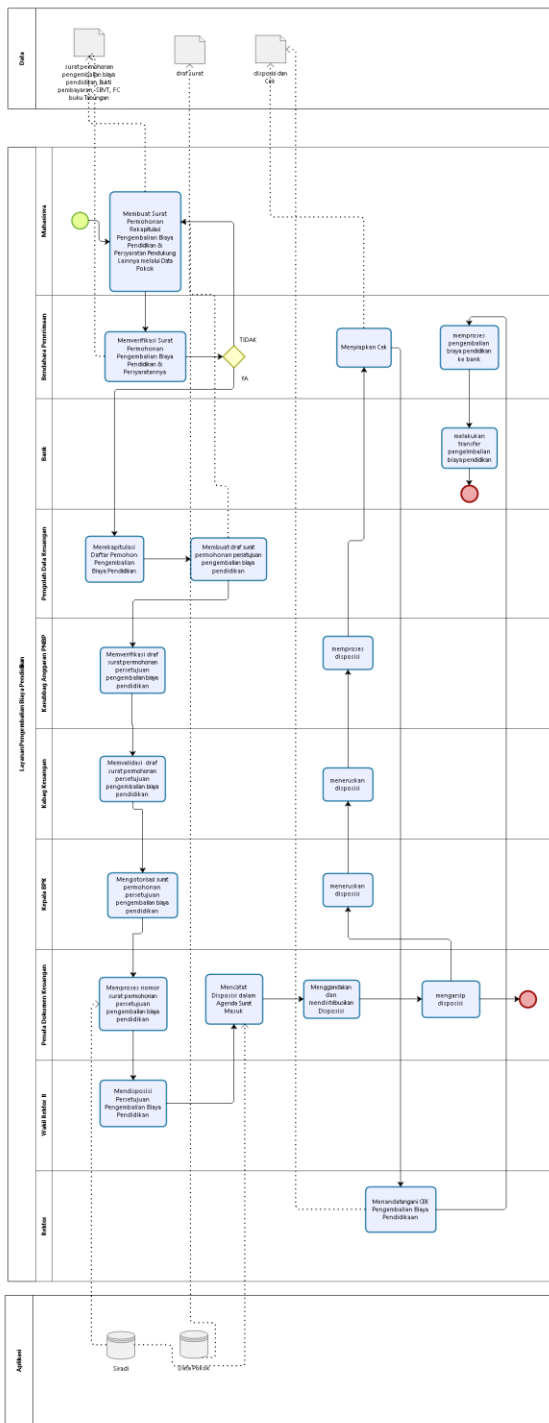

Level 4 Layanan Penetapan UKT Mahasiswa

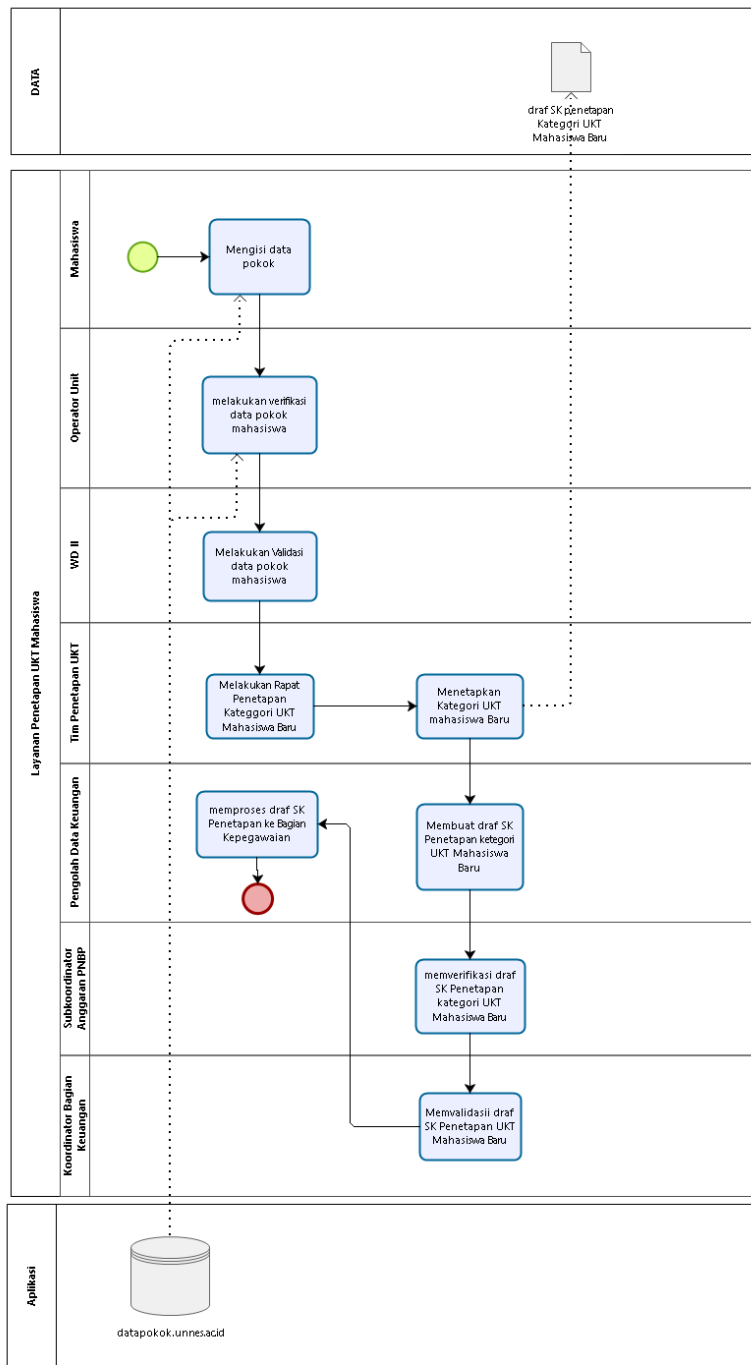

Level 4 Layanan Penetapan Ulang UKT Mahasiswa

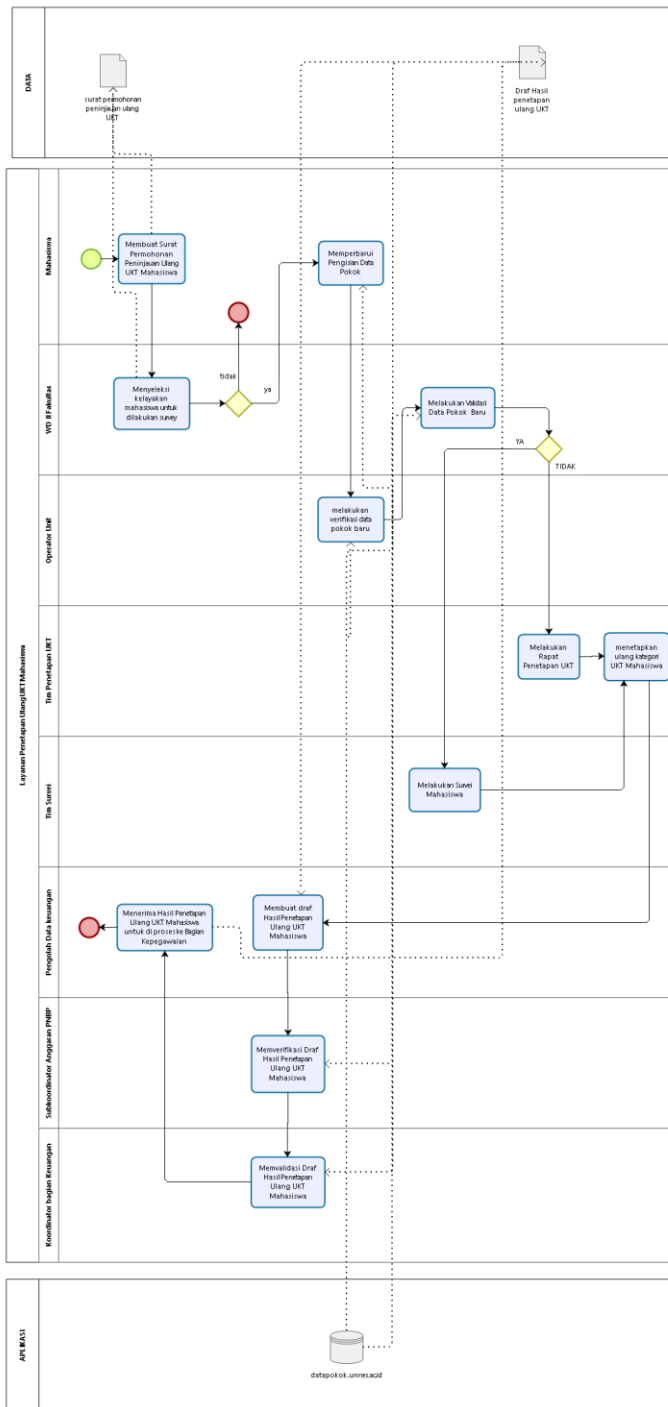

Level 4 Layanan Penerimaan Dana Kerjasama DIPA dan Dana Kelolaan

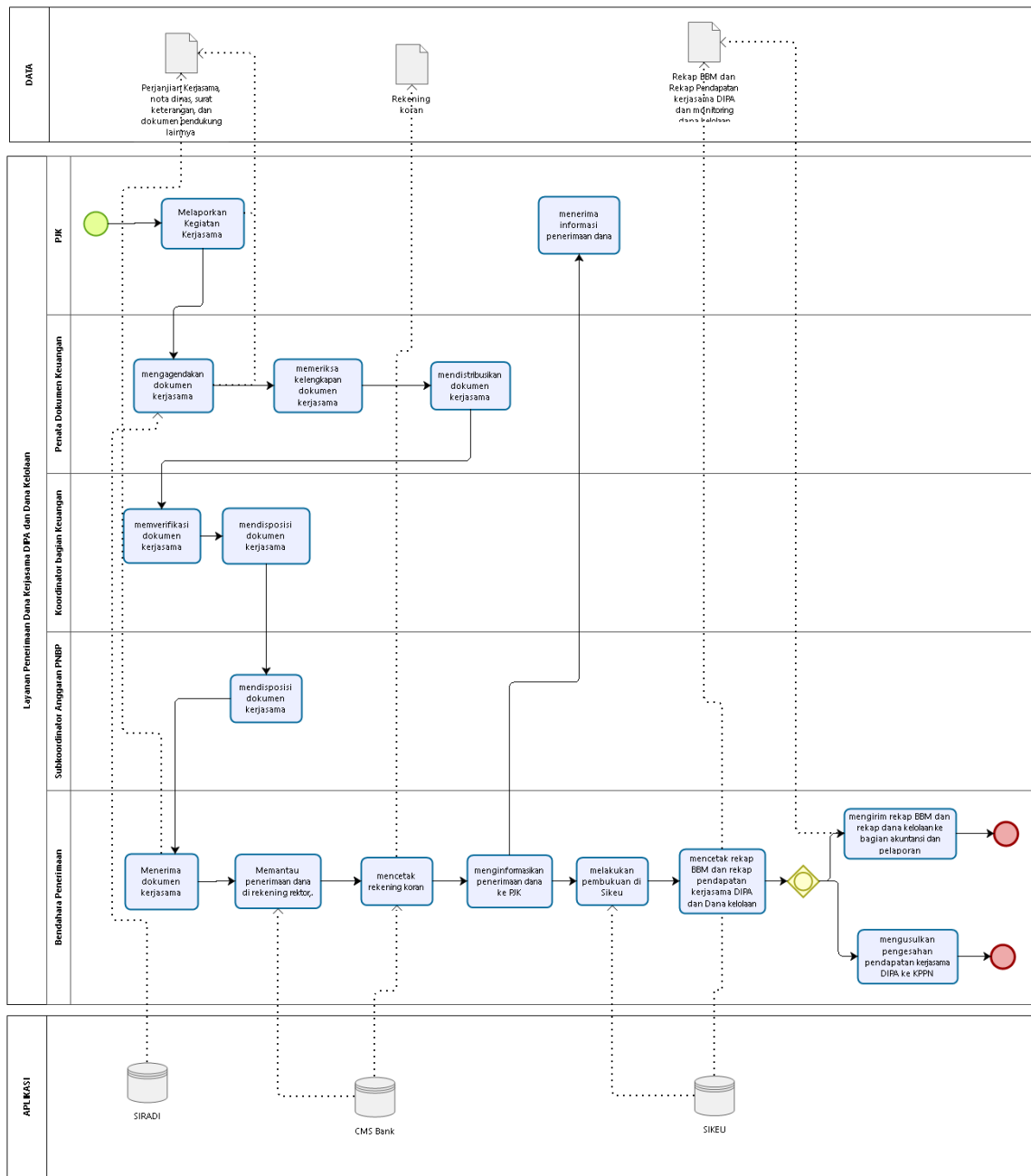

Level 4 Layanan Penerimaan Usaha Lainnya

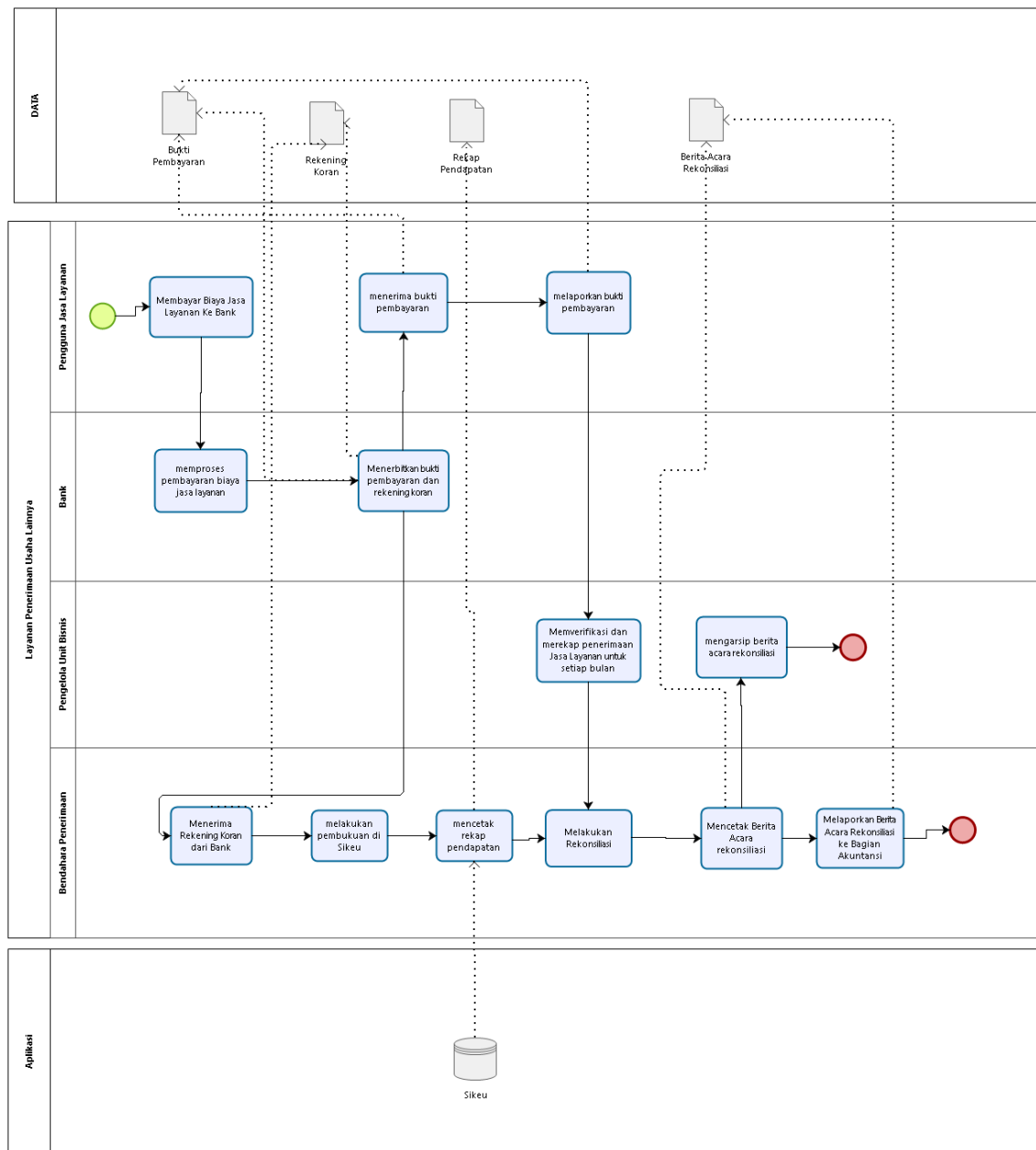

Level 4 Layanan Penerimaan Kontribusi Kegiatan

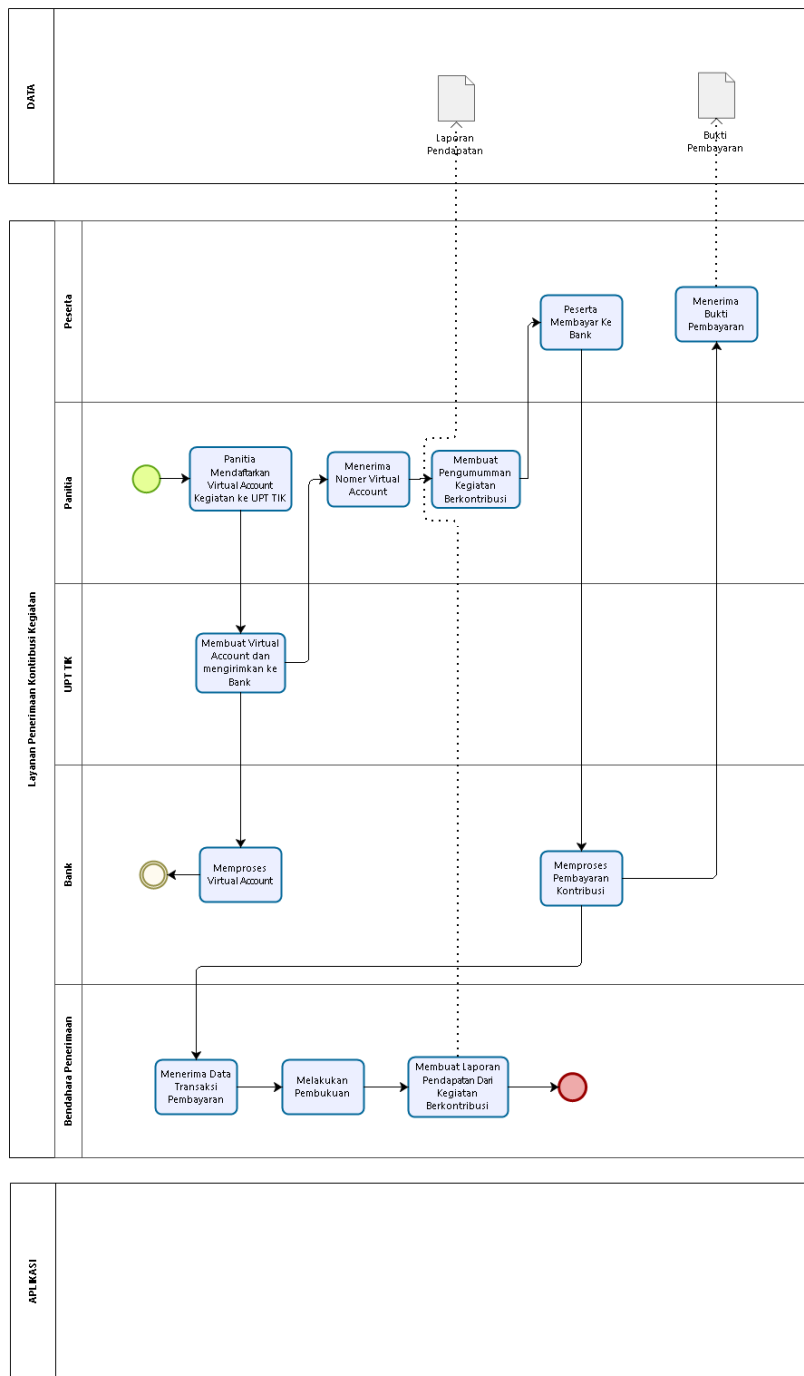

Level 4 Layanan Pengujian SPP dan Penerbitan SPUM

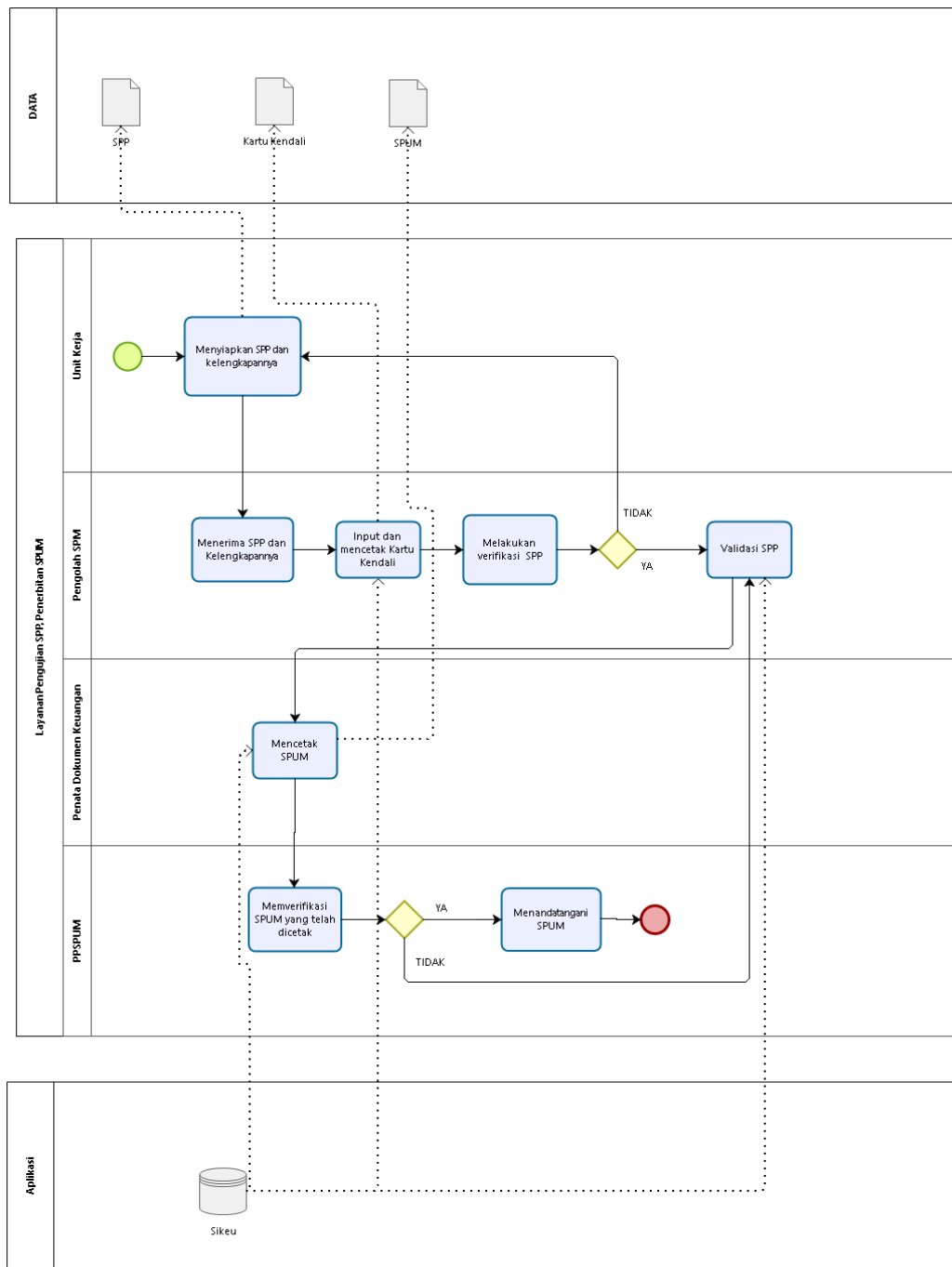

Level 4 Layanan Pelaporan Pajak

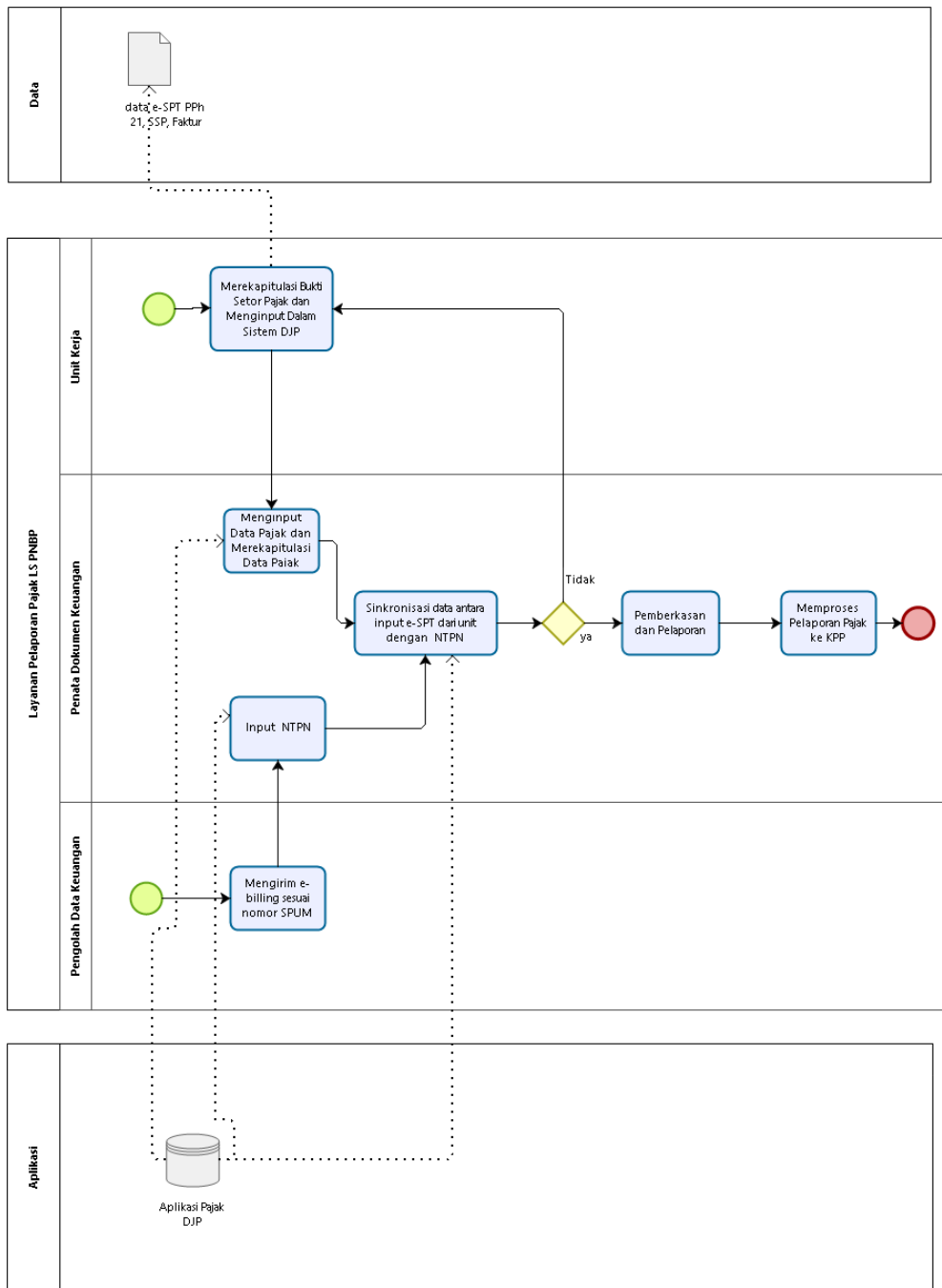

Level 4 Layanan Pengajuan SPP Gaji dan Tunjangan BLU

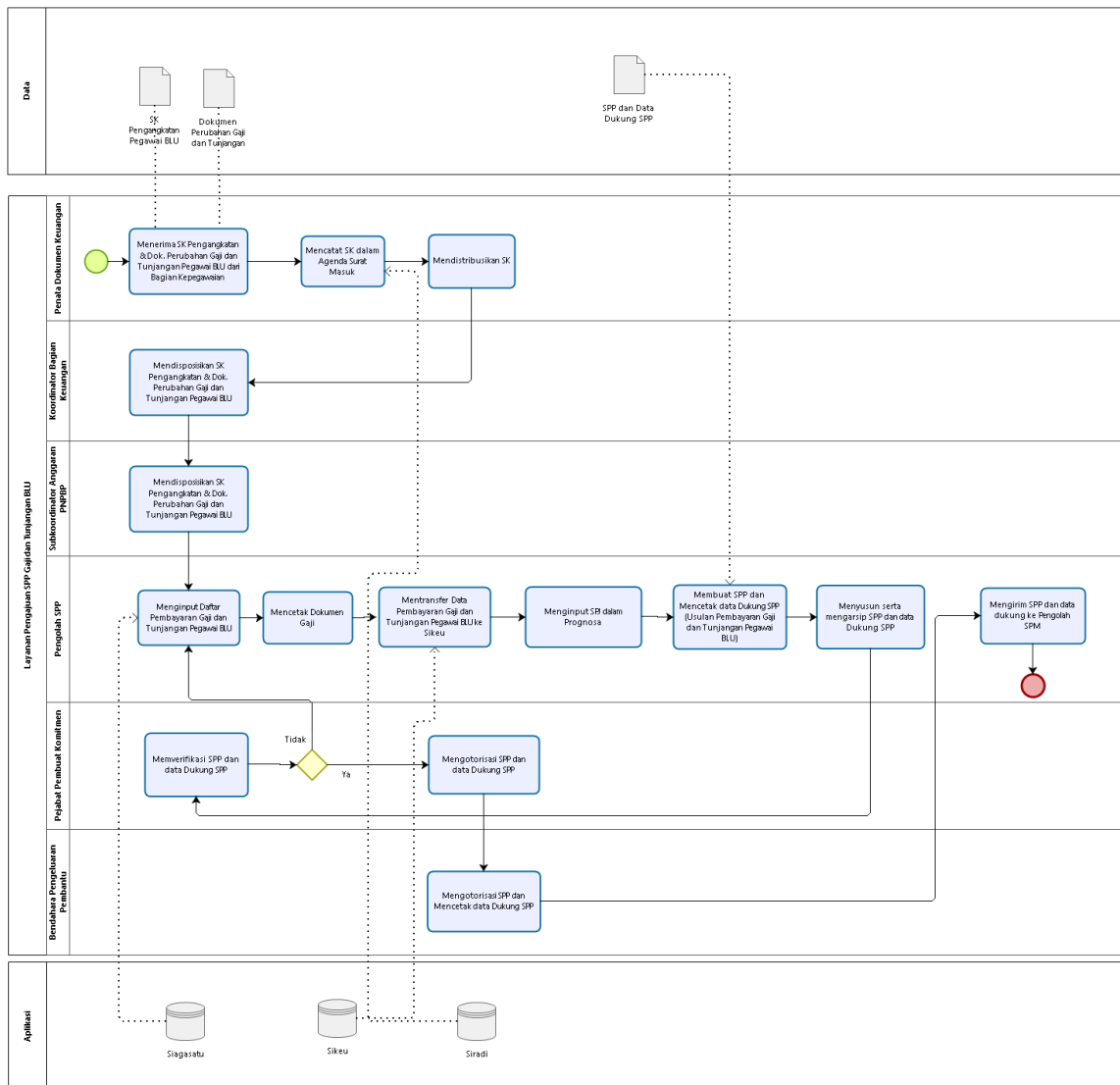

Level 4 Layanan Pembayaran Belanja PNB

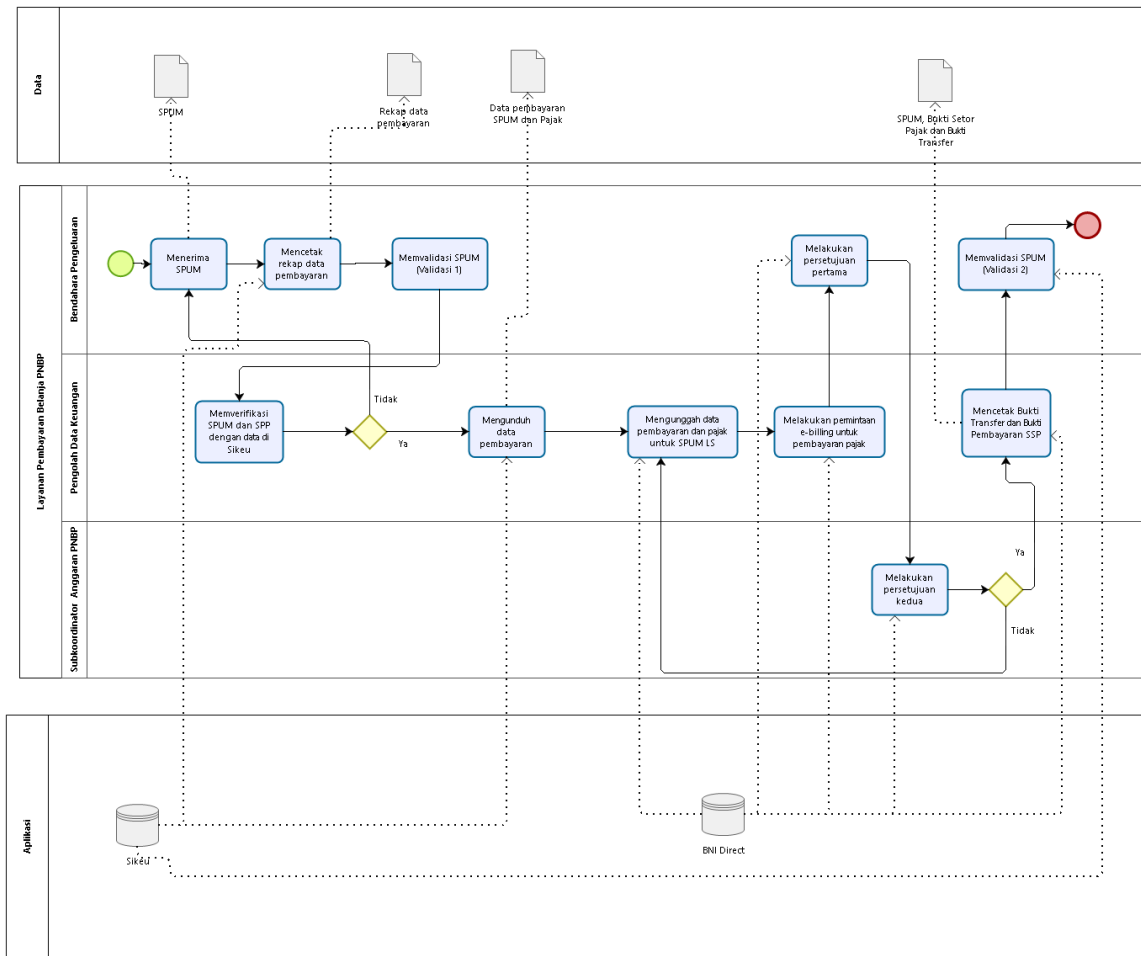

Level 4 Layanan Pengesahan SP3B

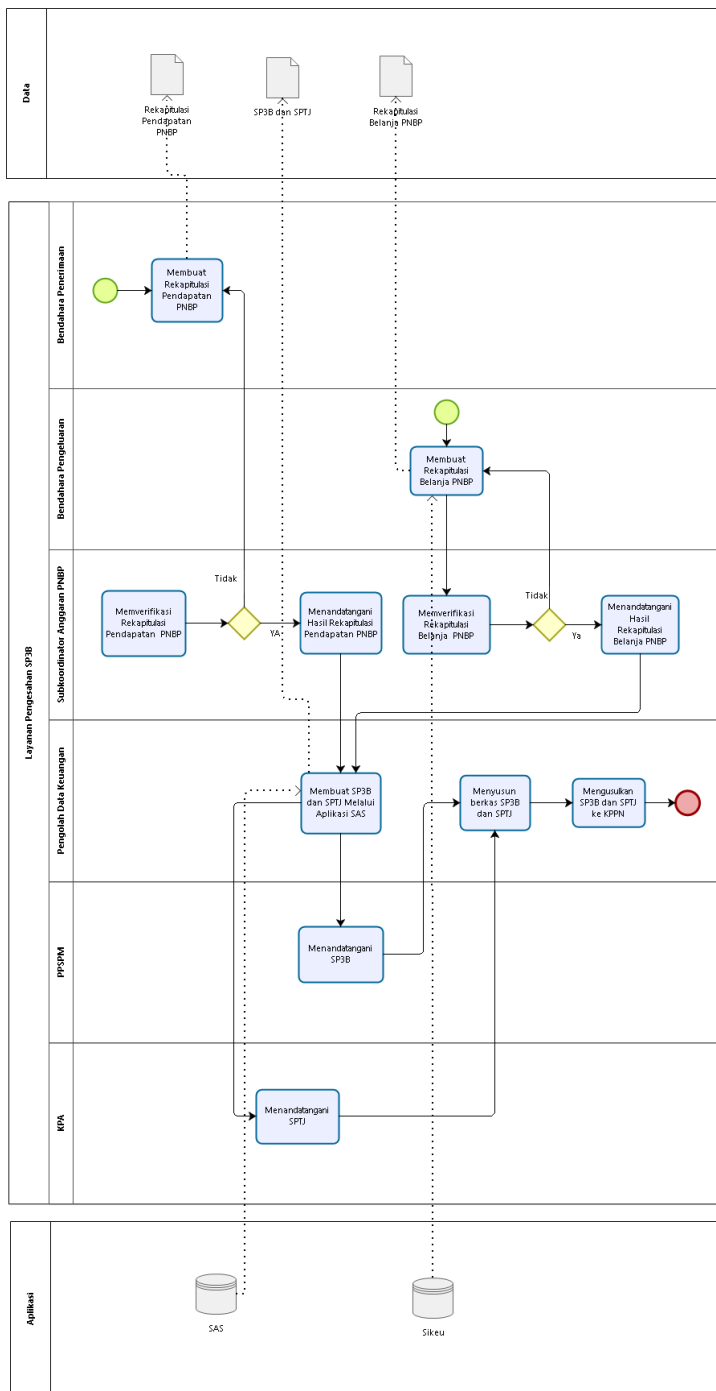

Level 4 Layanan Pembukuan Sumber Dana PNBP

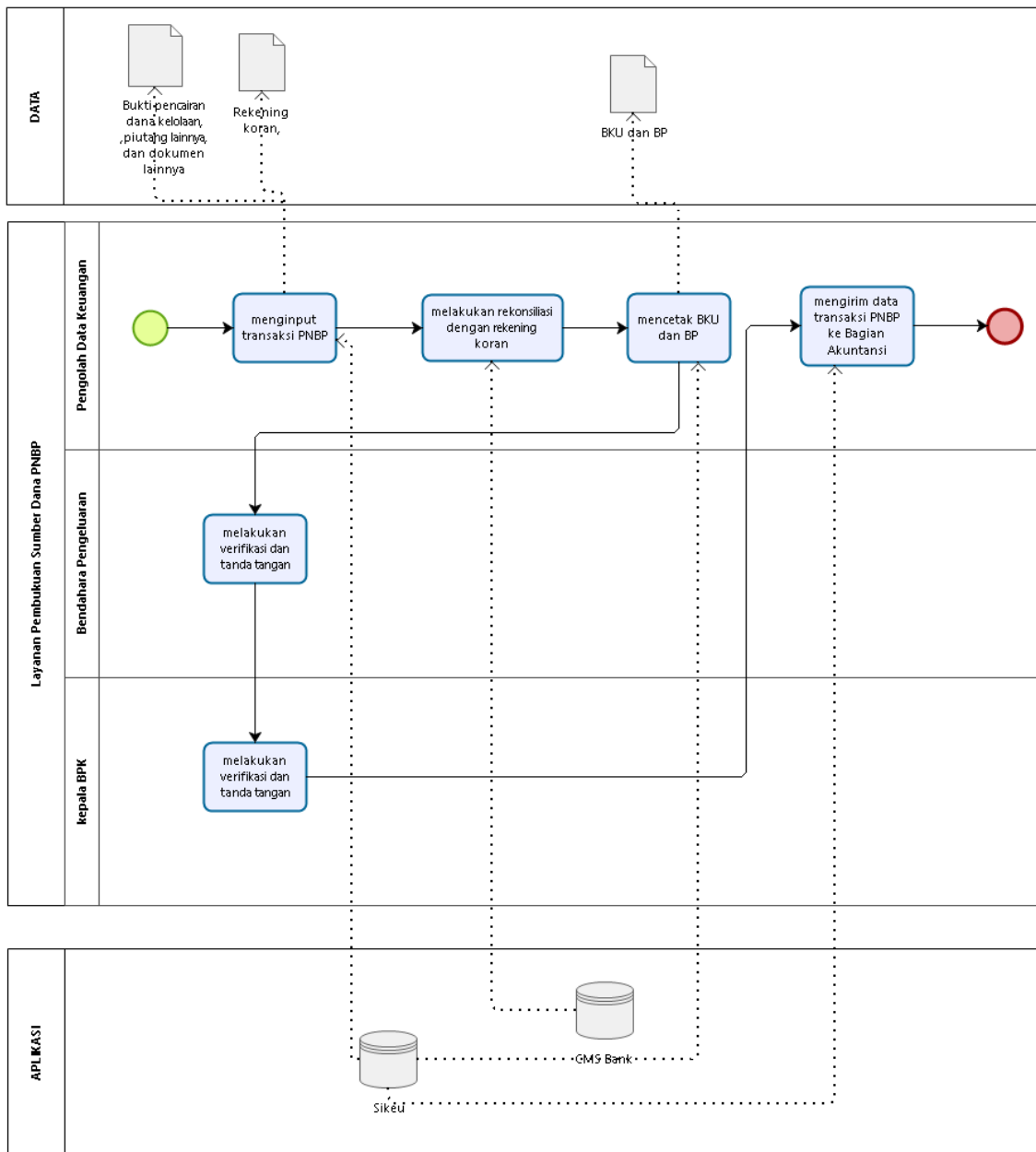

Level 4 Layanan Pengisian Kas Bendahara Pengeluaran

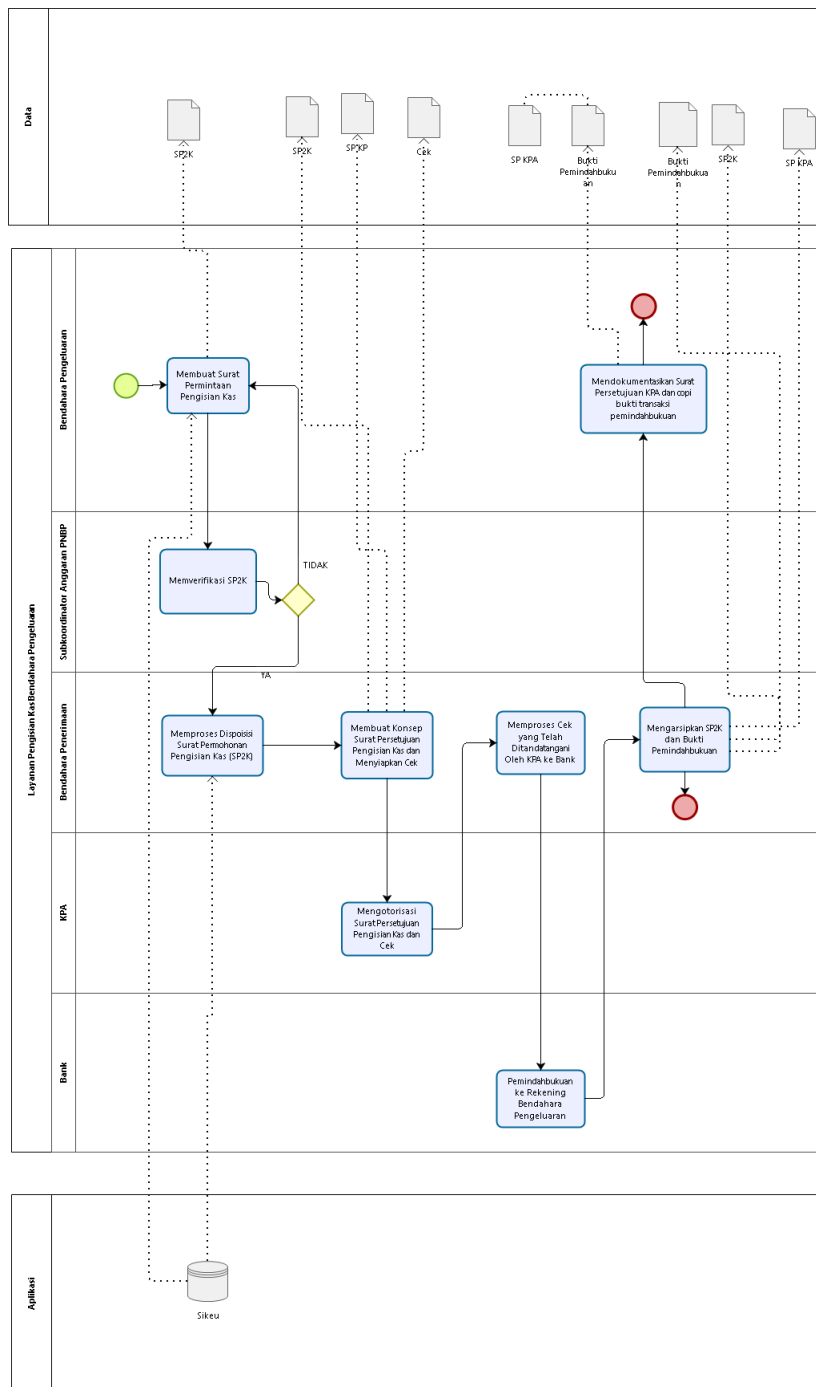

Level 4 Layanan Pencairan Dana Kelolaan

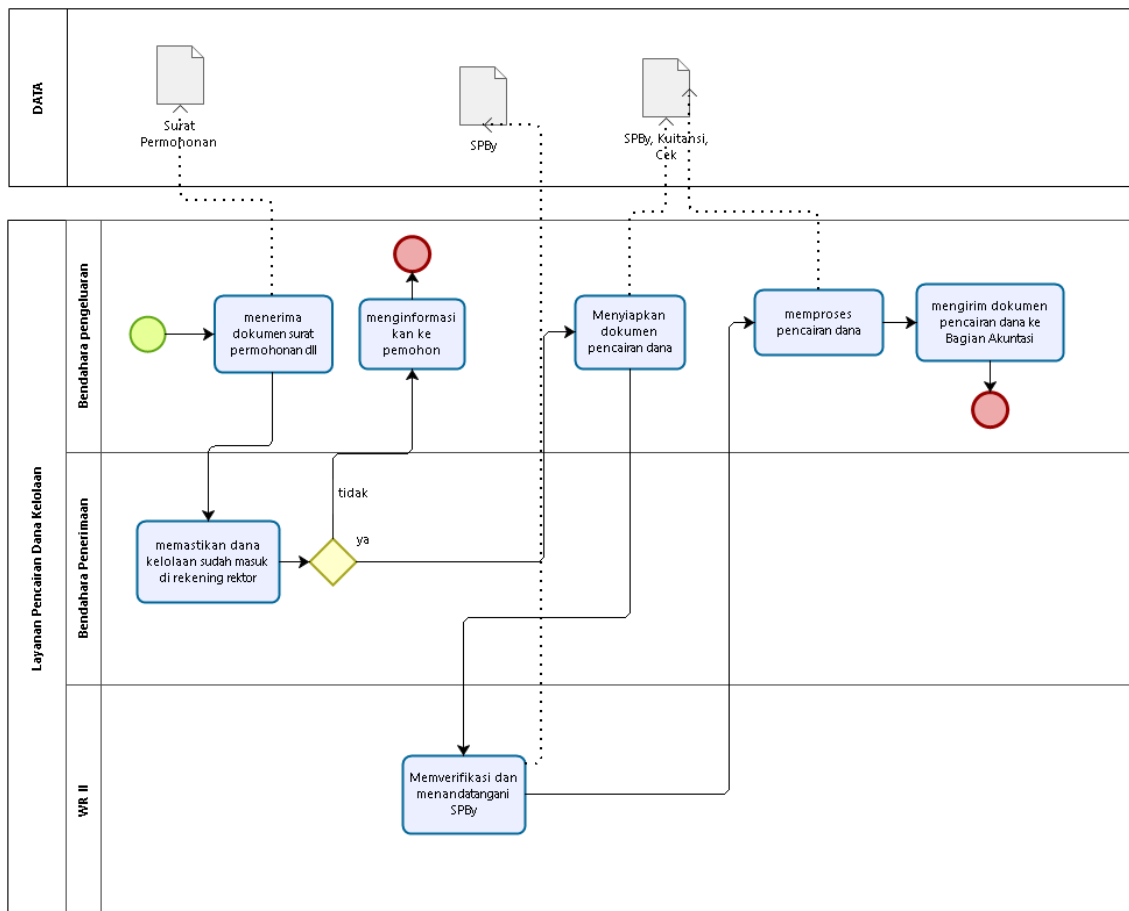

Level 4 Layanan Piutang Lainnya

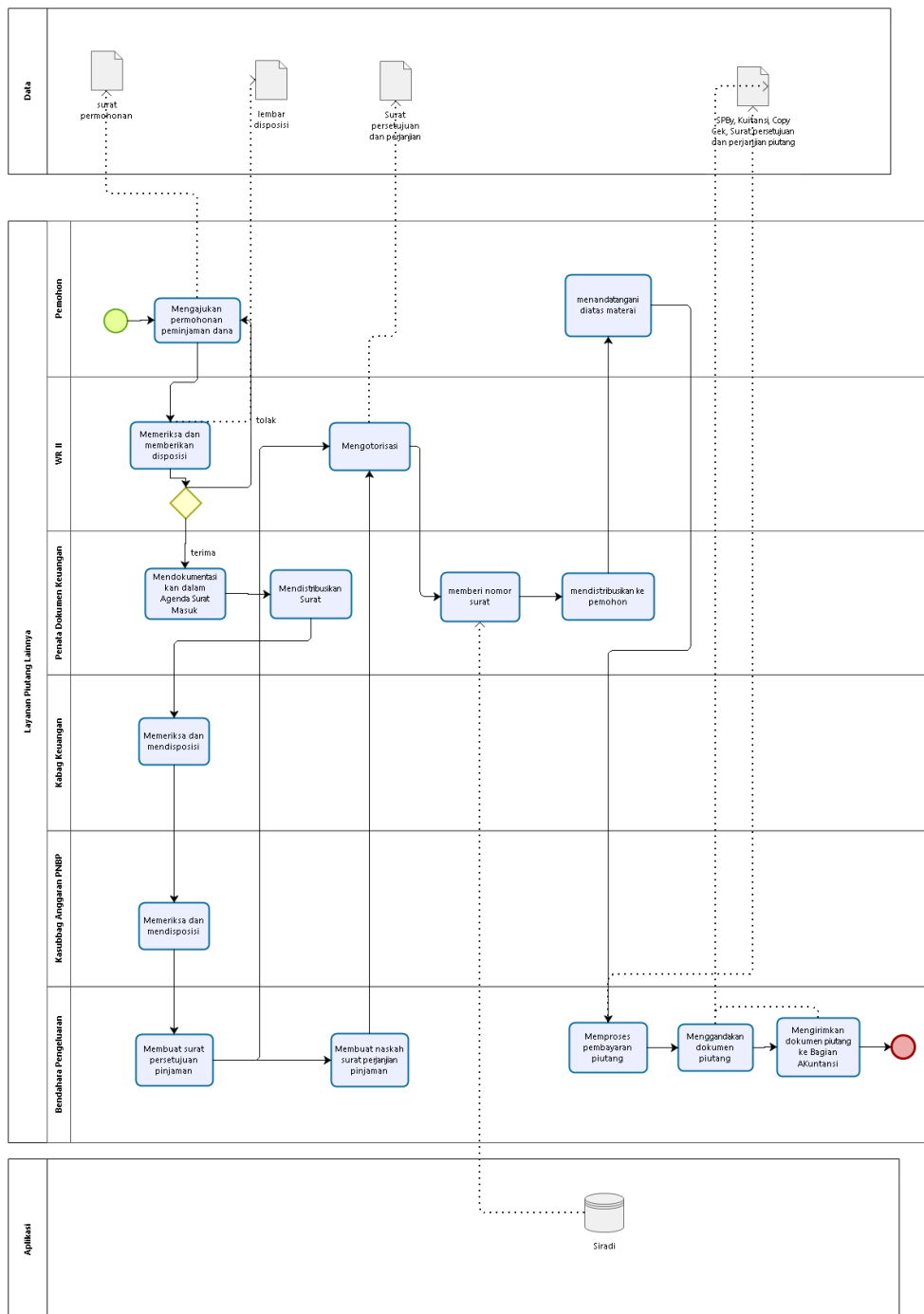

Level 4 Layanan Penatausahaan SP2B

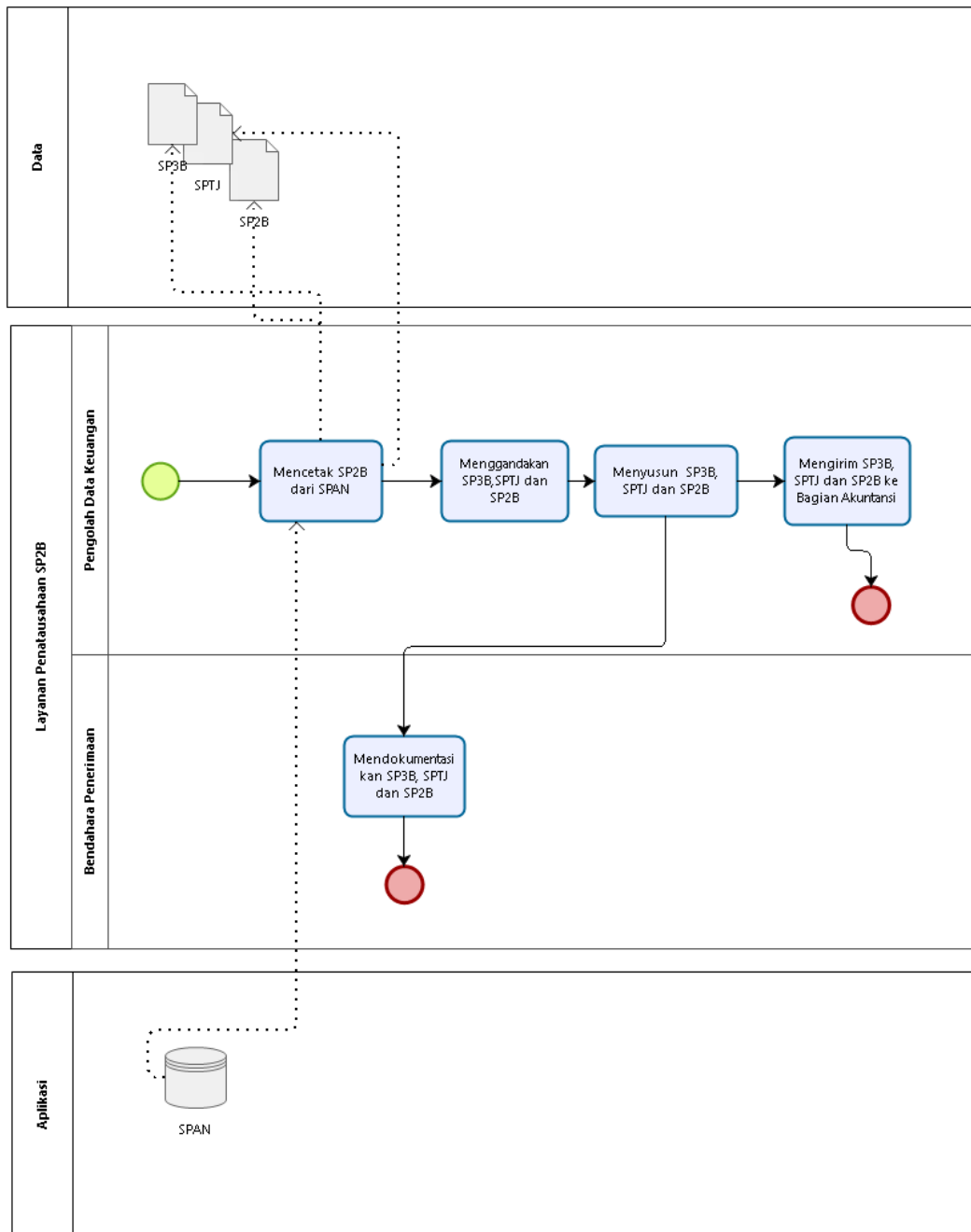

Level 4 Layanan Usulan Rencana Penarikan Dana

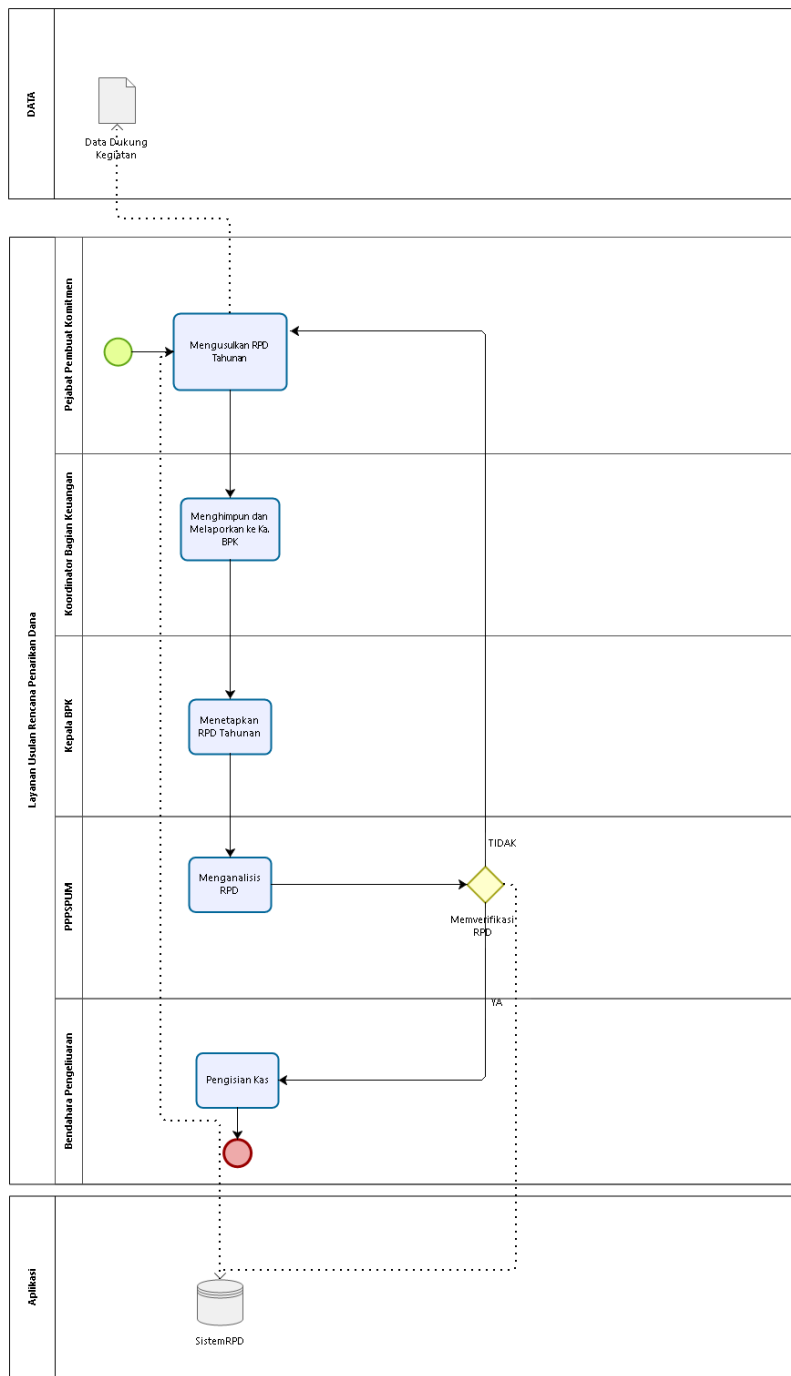

Level 3 Layanan Non PNBP

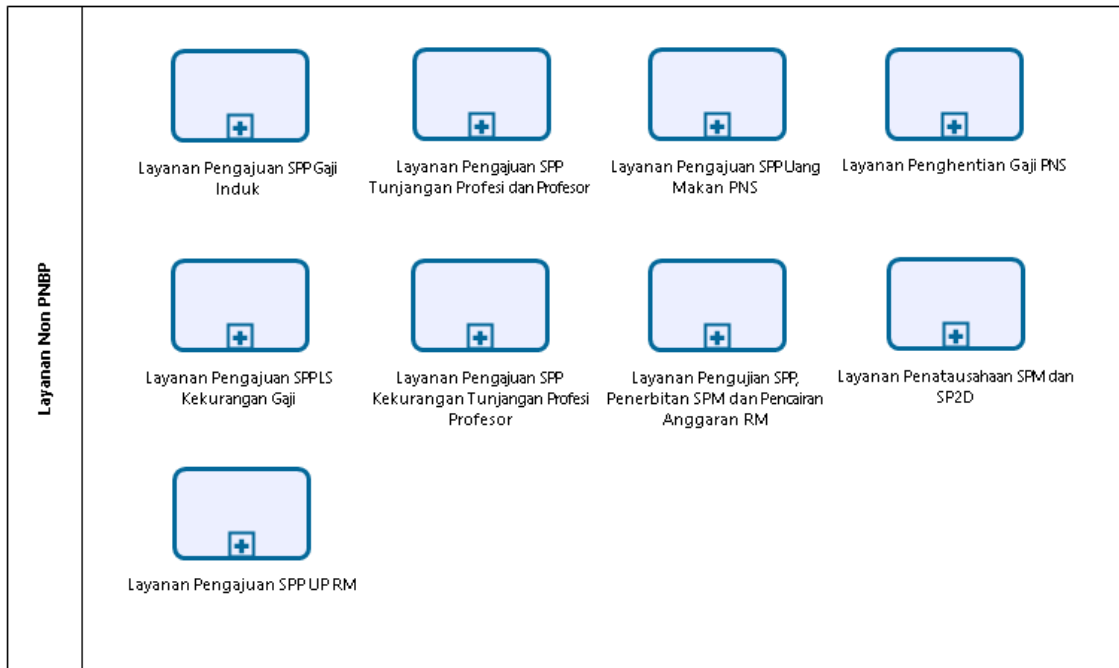

Level 4 Layanan Pengajuan SPP Gaji Induk

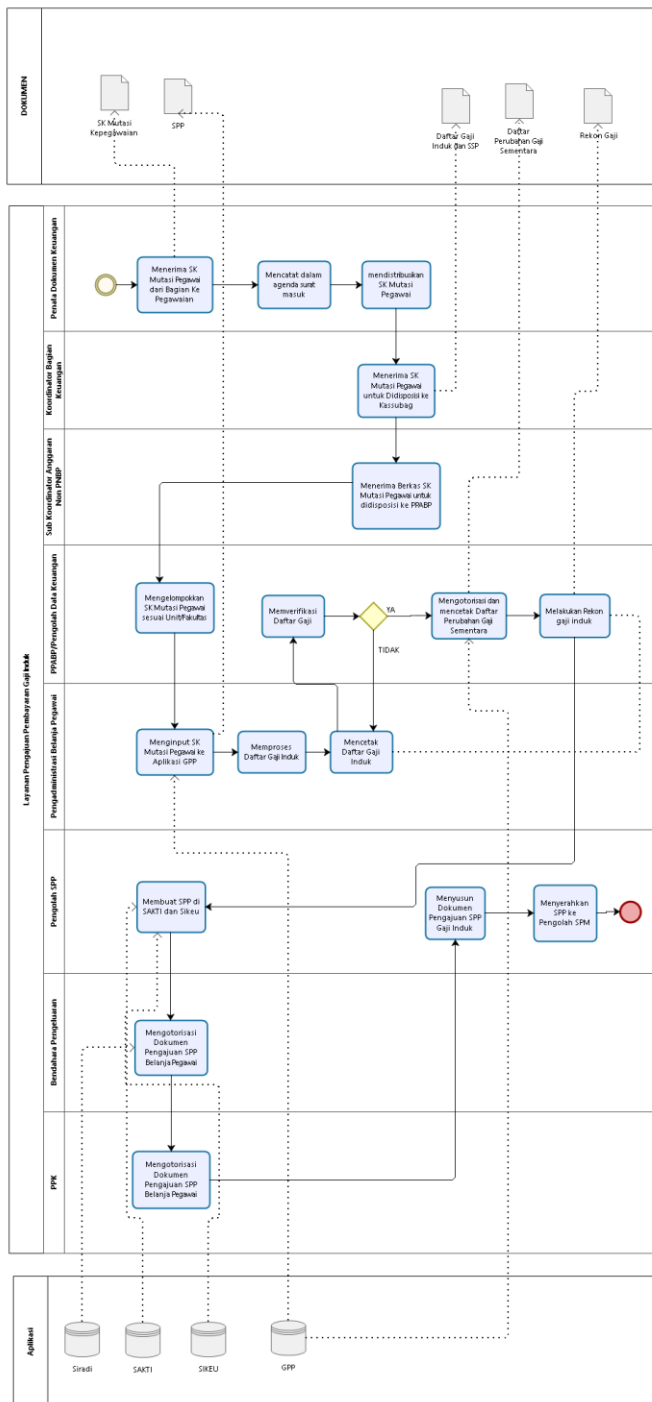

Level 4 Layanan Pengajuan SPP Tunjangan Profesi dan Profesor

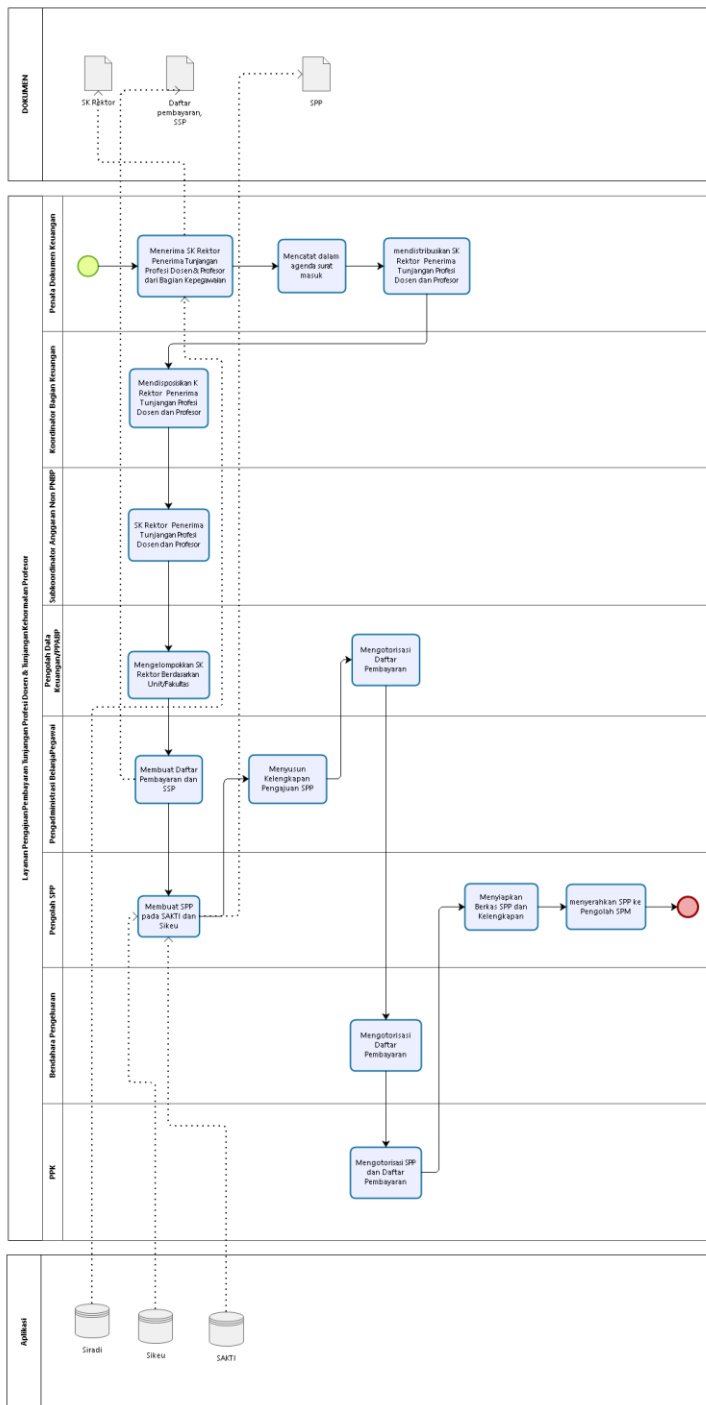

Level 4 Layanan Pengajuan SPP Uang Makan PNS

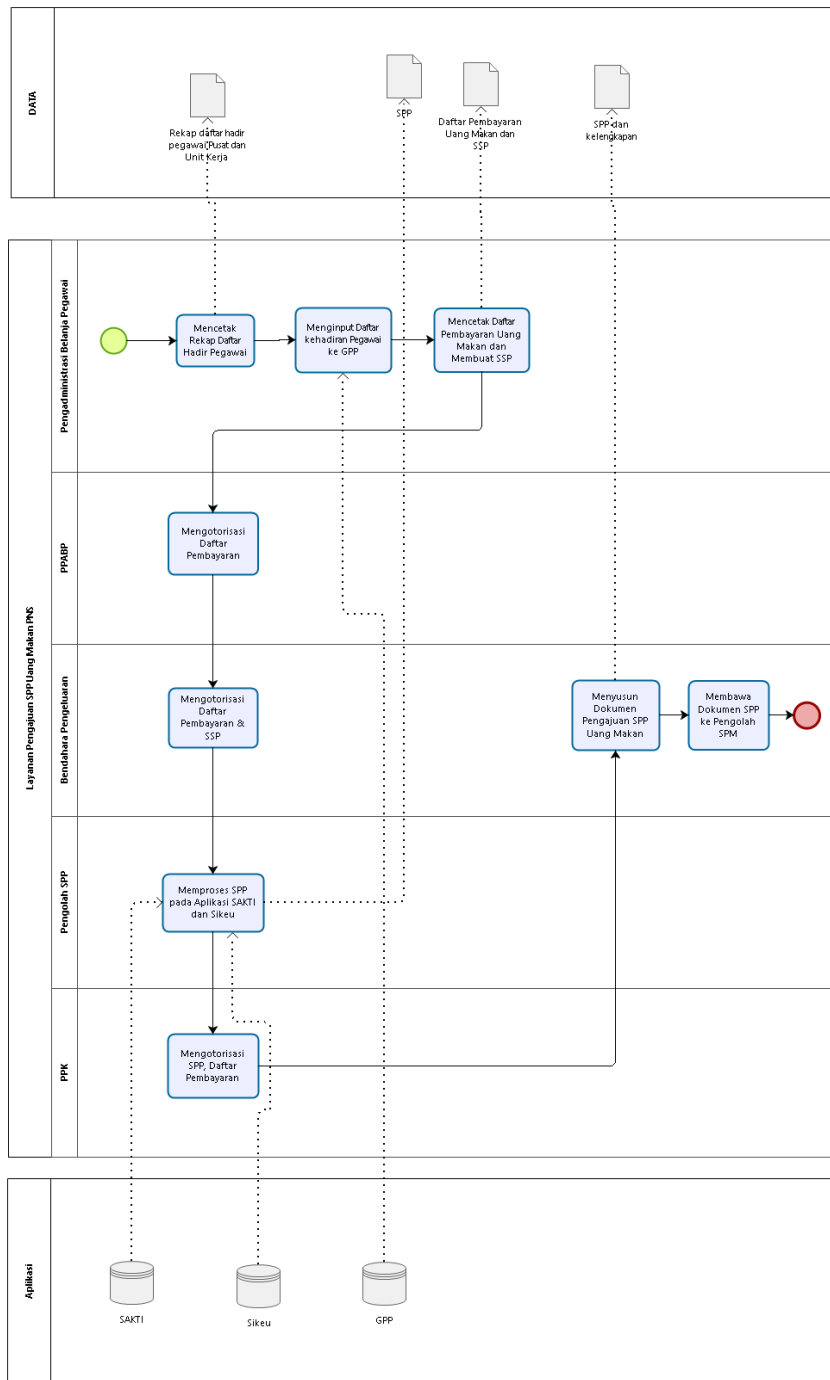

Level 4 Layanan Penghentian Gaji PNS

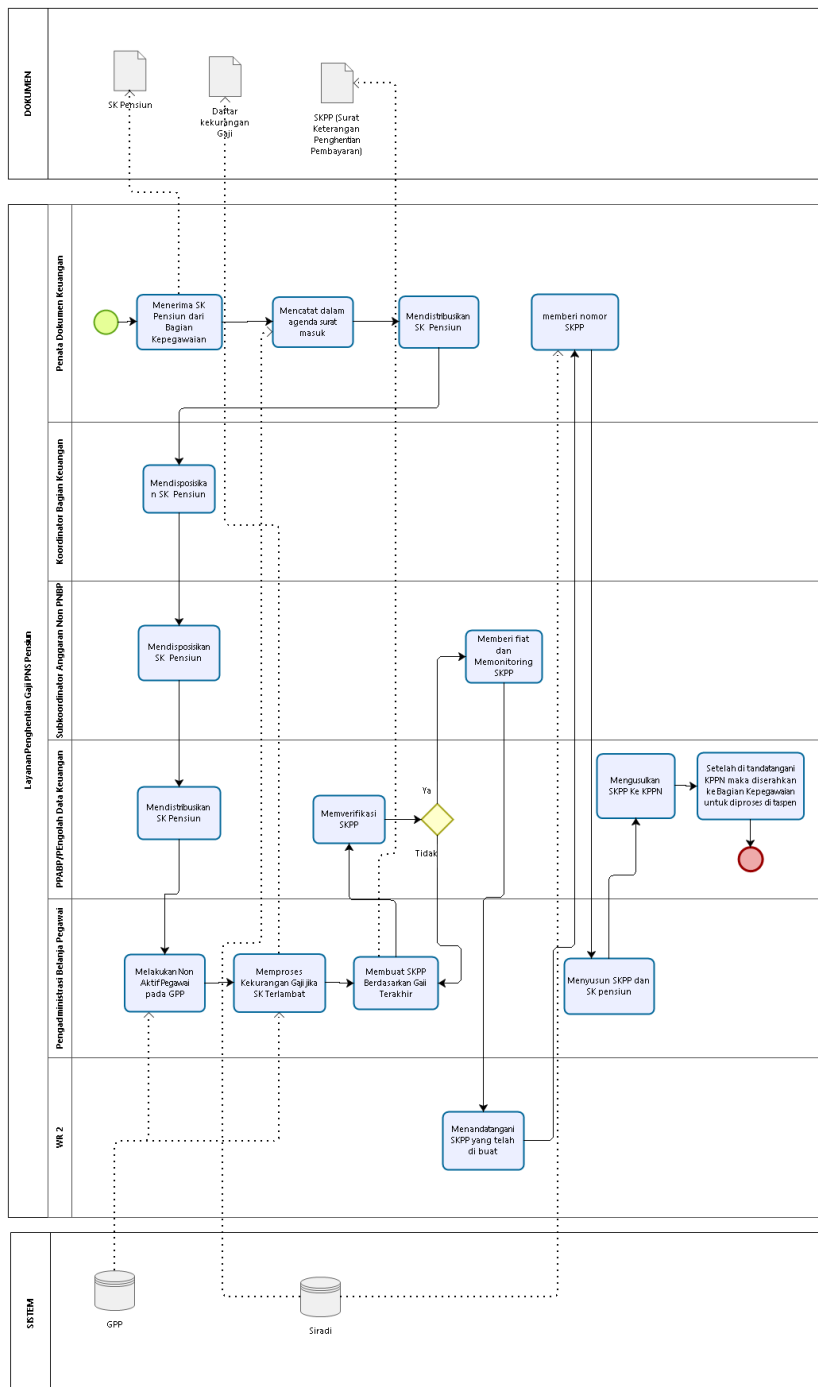

Level 4 Layanan Pengajuan SPP LS Kekurangan Gaji

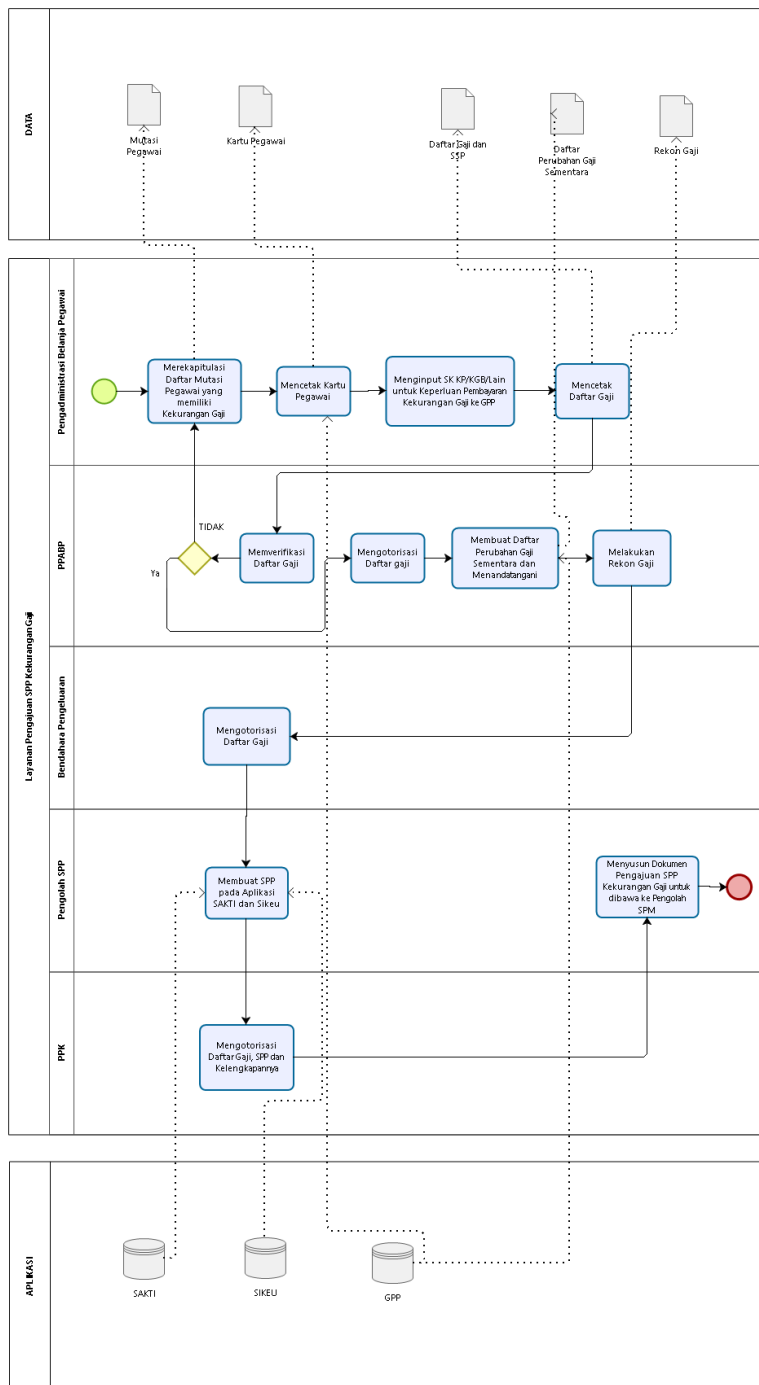

Level 4 Layanan Pengajuan SPP Kekurangan Tunjangan Profesi dan Profesor

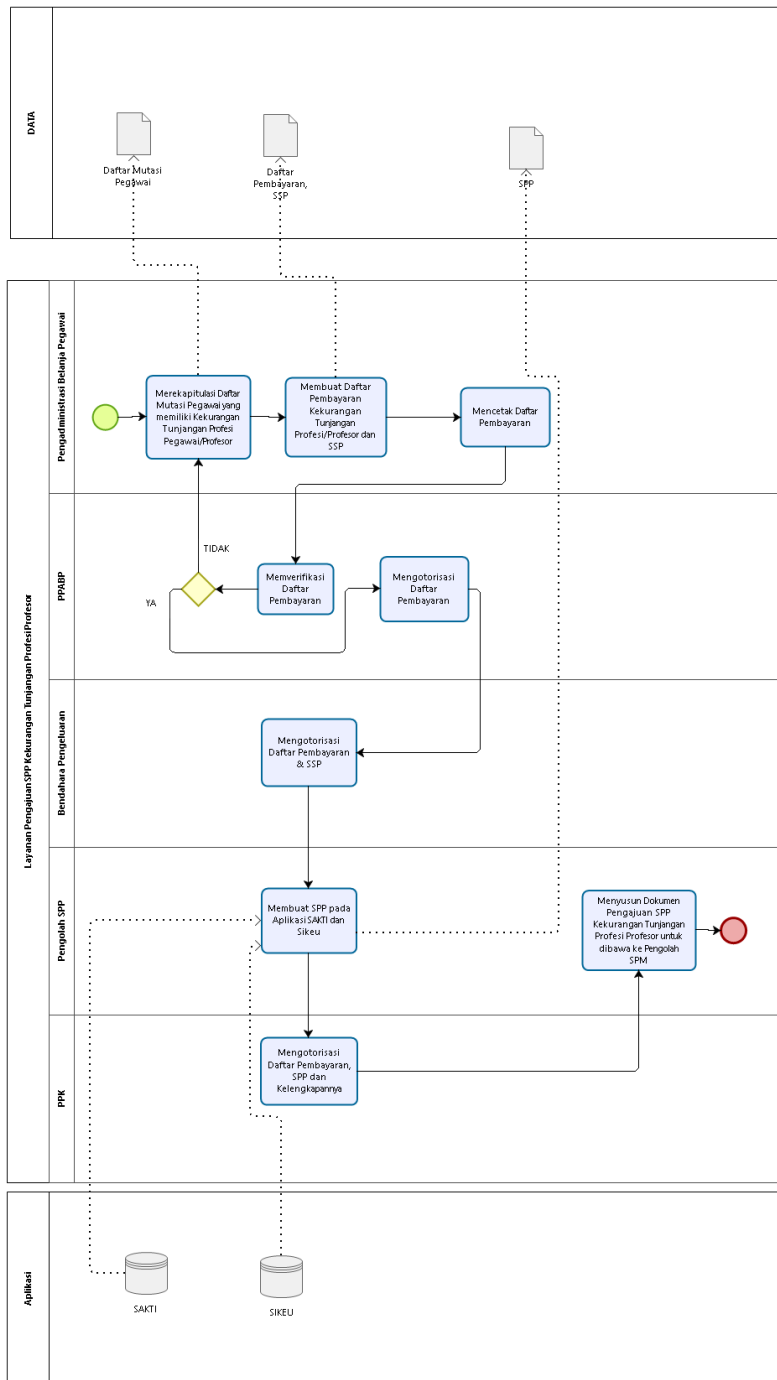

Powered by
bizagi
Modeler

Level 4 Layanan Pengujian SPP, Penerbitan SPM dan Pencairan Anggaran RM

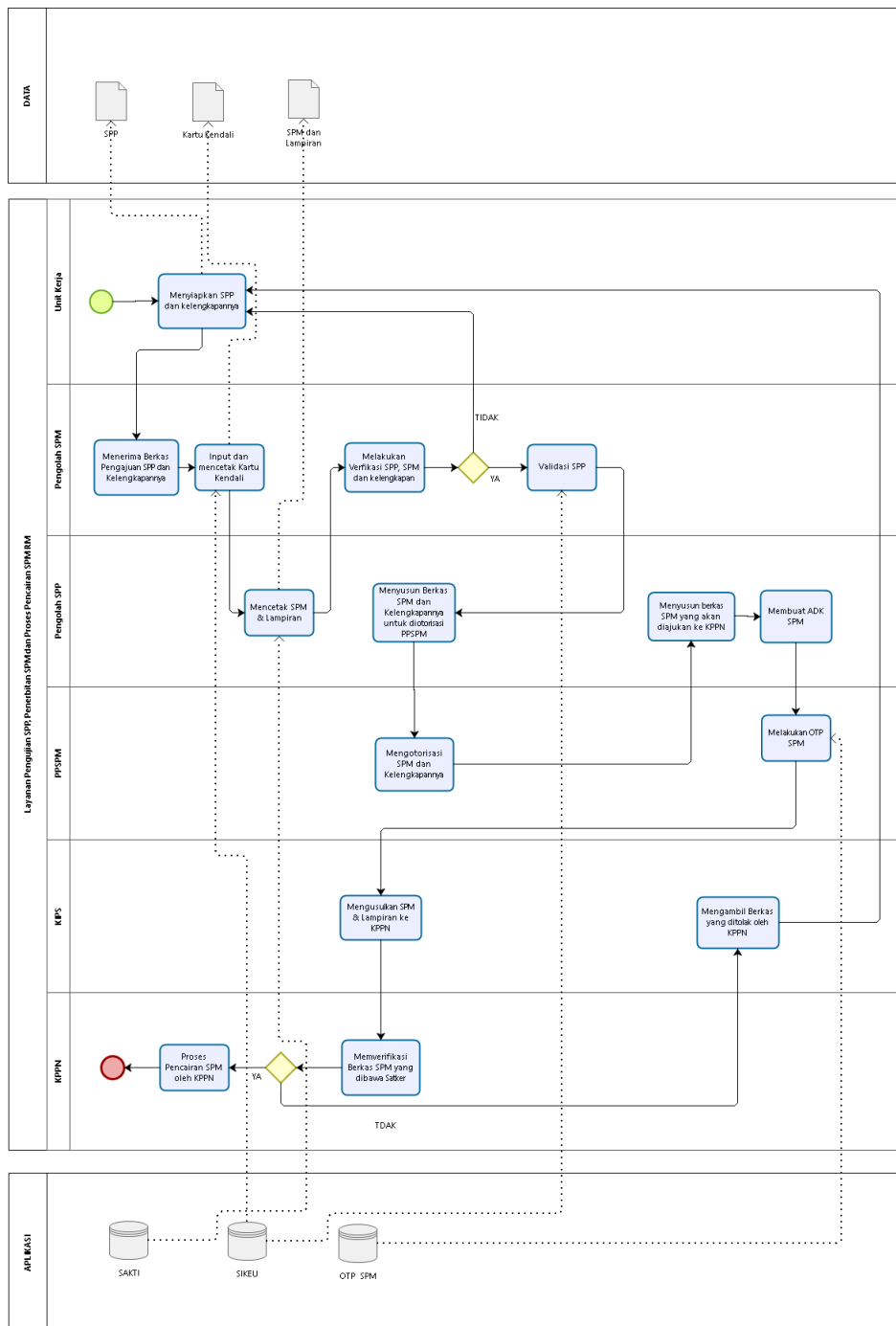

Level 4 Layanan Penatausahaan SPM dan SP2D

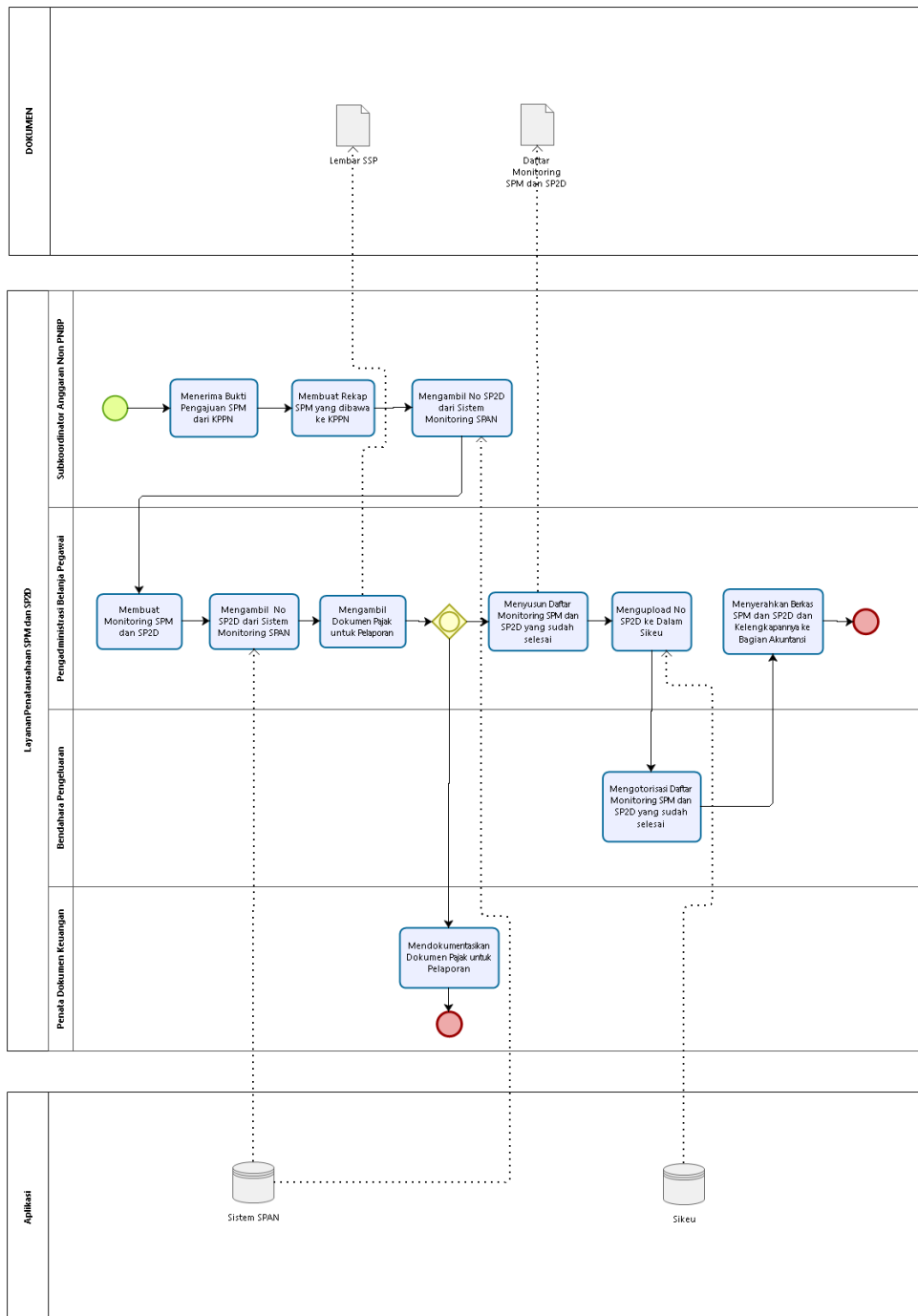

Level 4 Layanan Pengajuan SPP UP RM

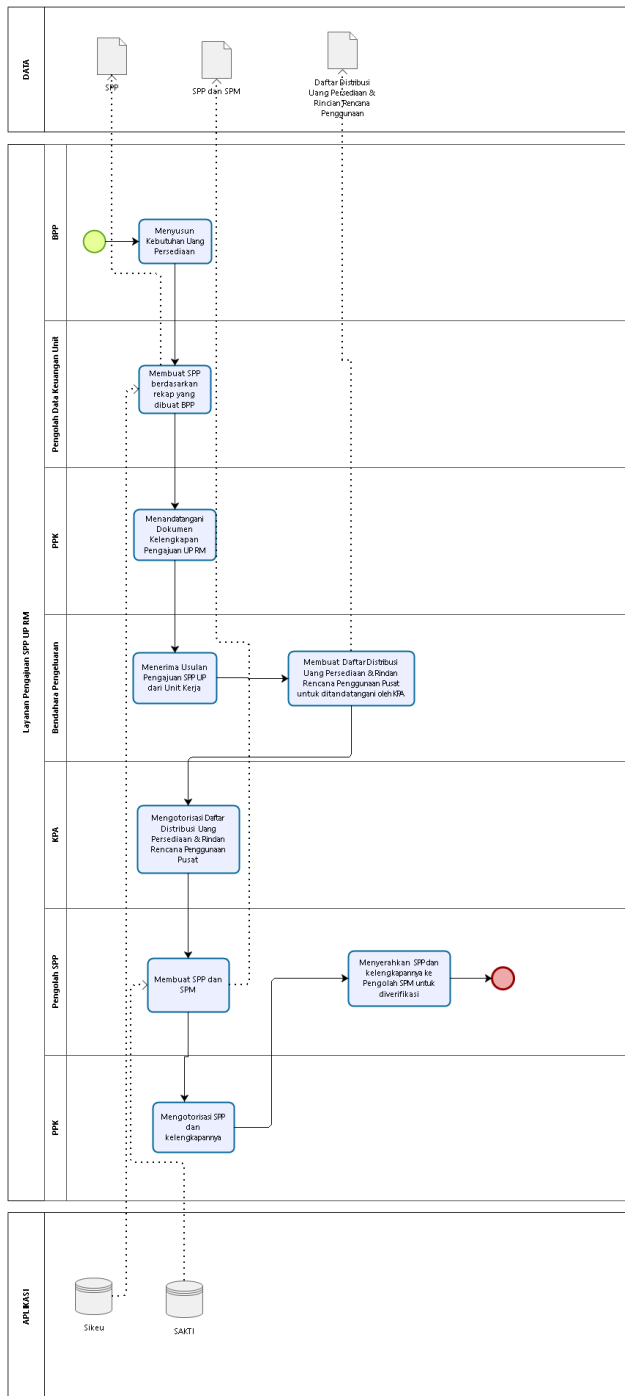

Powered by bizagi Mobile

Level 2 Layanan Akuntansi

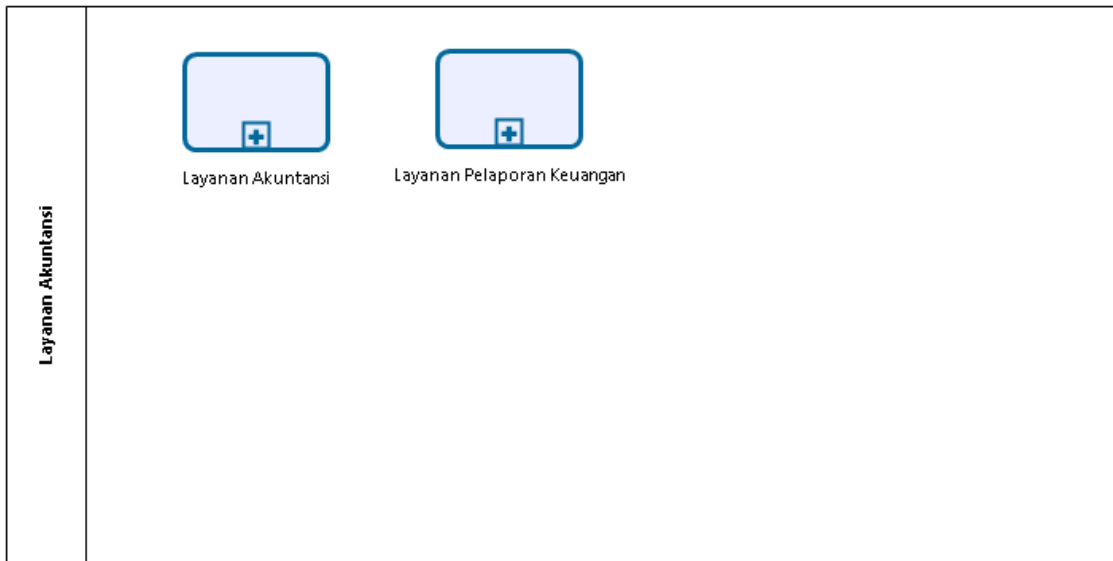

Powered by
bizagi
Modeler

Level 3 Layanan Akuntansi

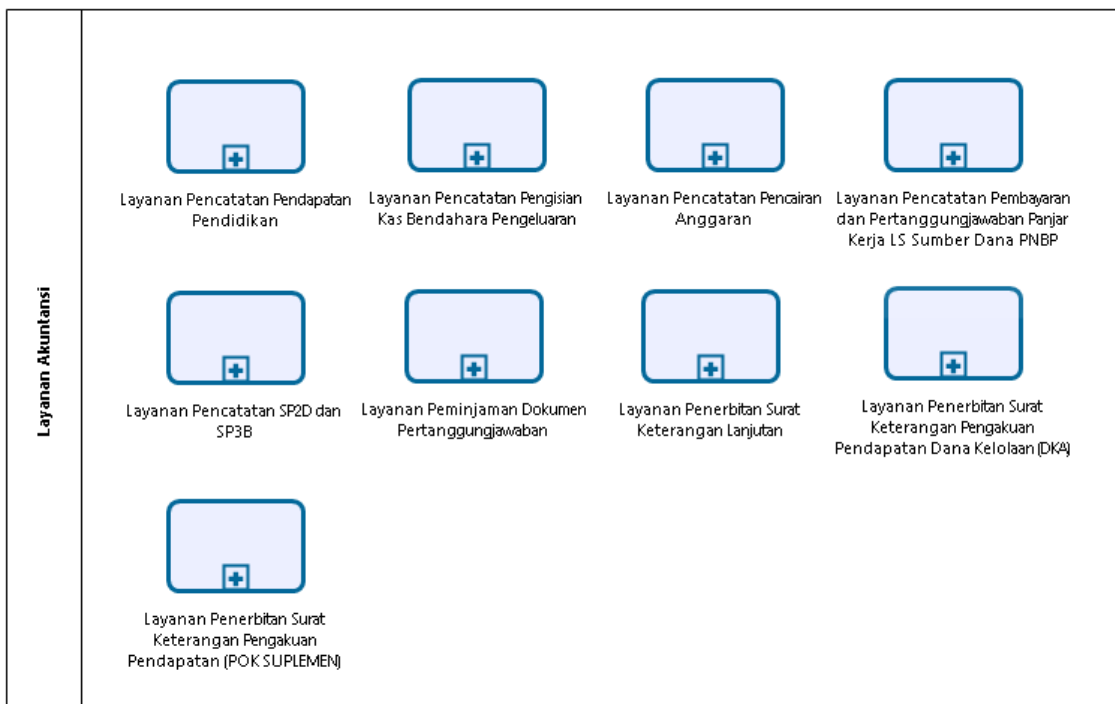

Powered by
bizagi
Modeler

Level 4 Layanan Pencatatan Pendapatan Pendidikan

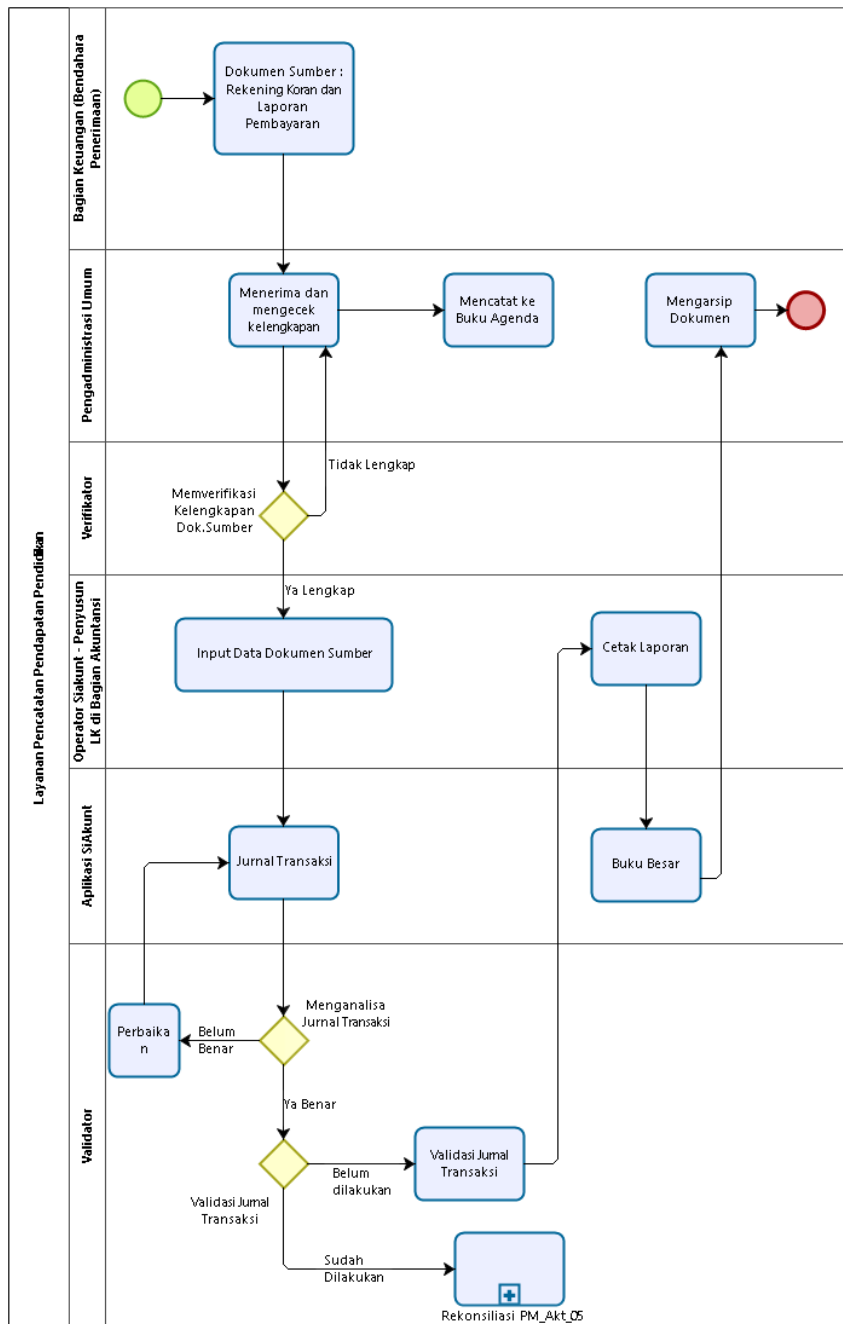

Level 4 Layanan Pencatatan Pengisian Kas Bendahara Pengeluaran

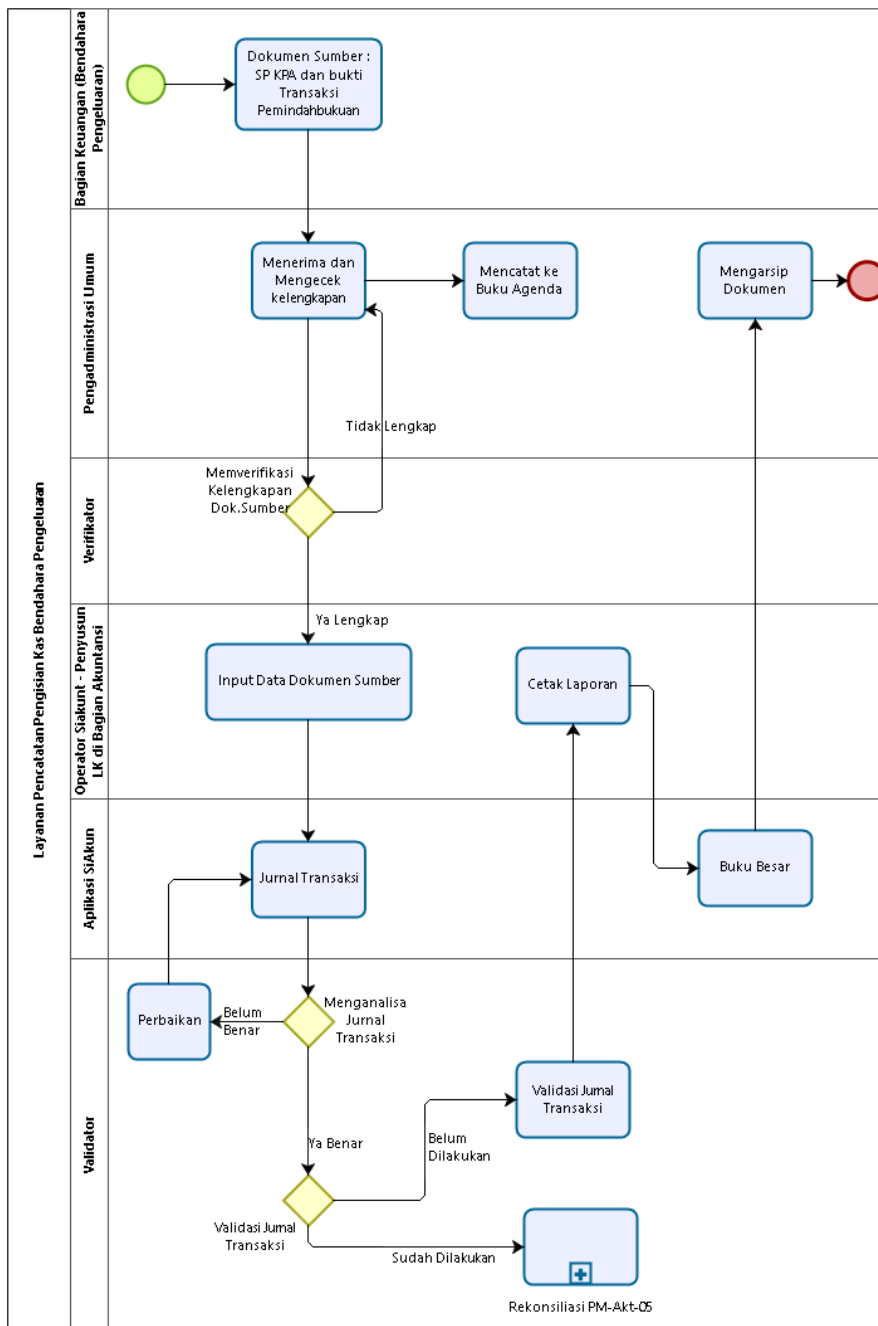

Level 4 Layanan Pencatatan Pencairan Anggaran

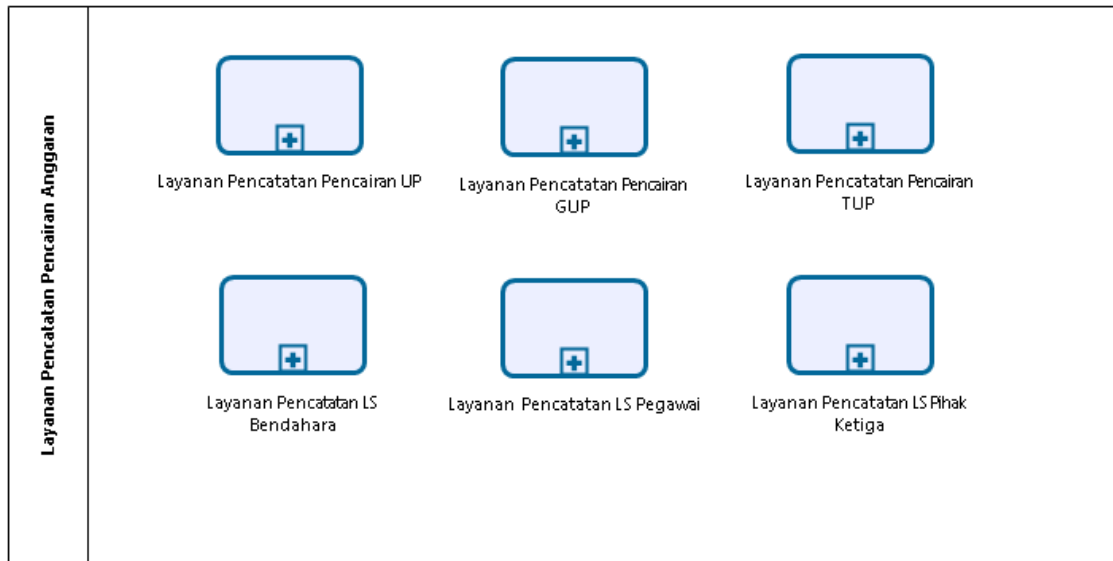

Level 5 Layanan Pencatatan Pencairan UP

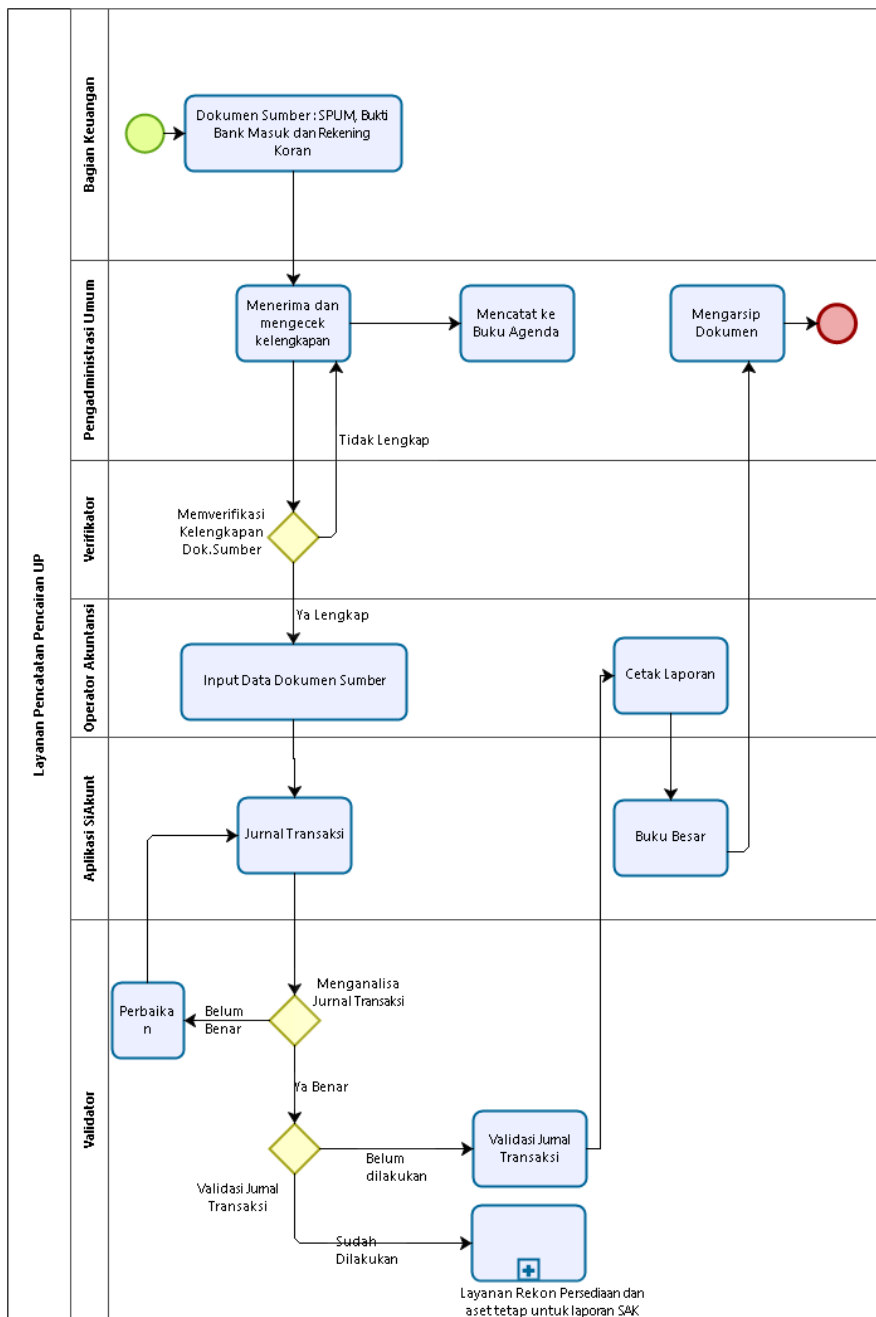

Level 5 Layanan Pencatatan Pencairan GUP

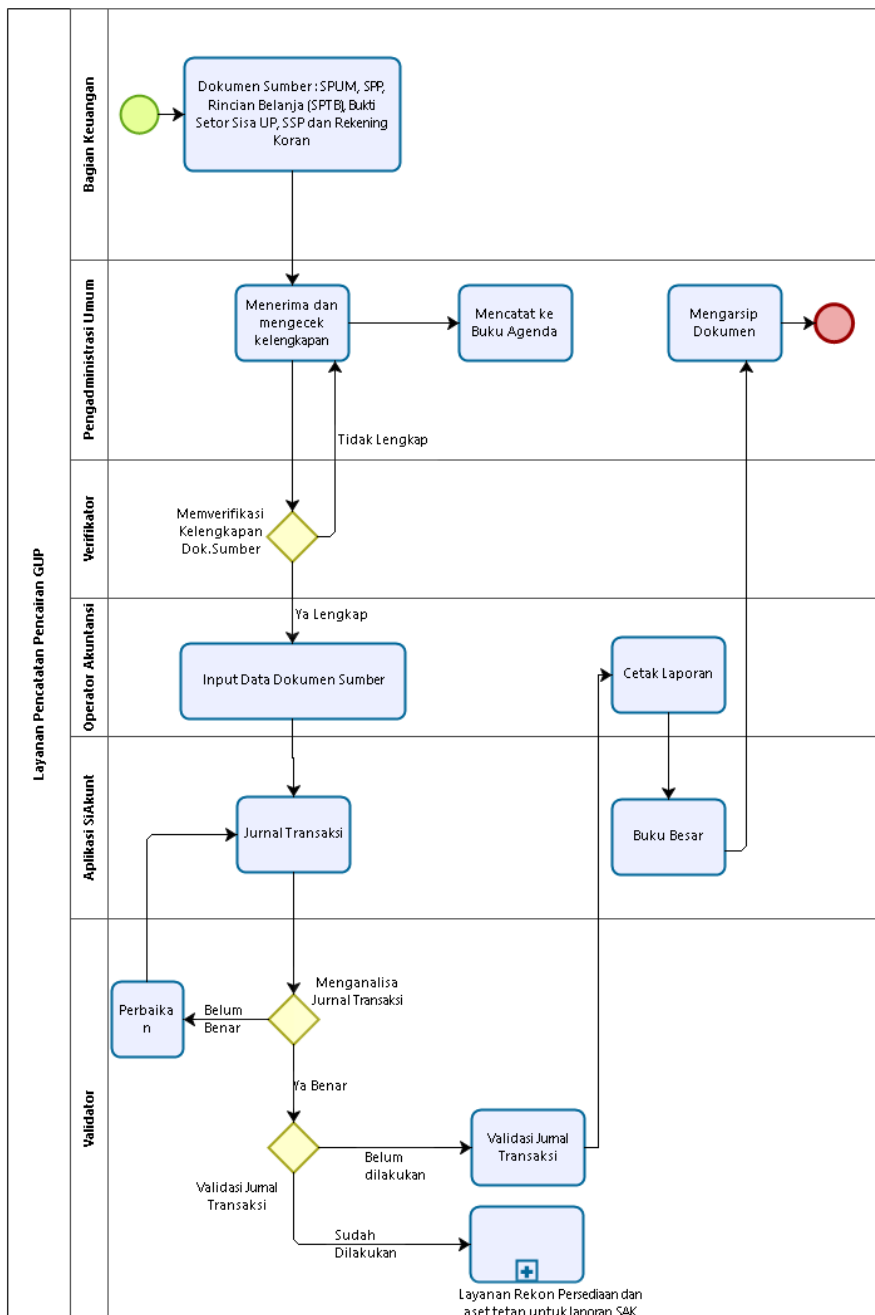

Level 5 Layanan Pencatatan Pencairan TUP

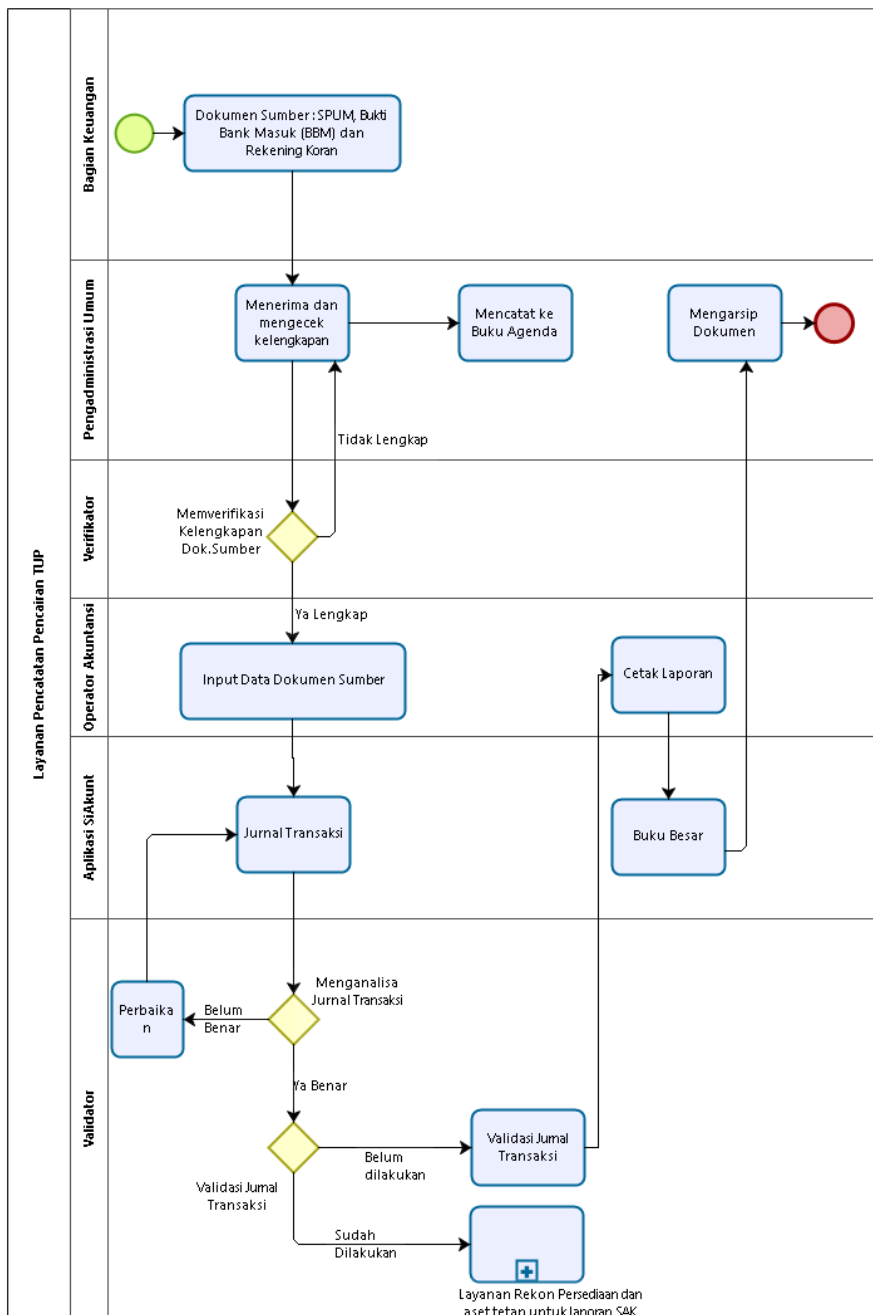

Level 5 Layanan Pencatatan LS Bendahara

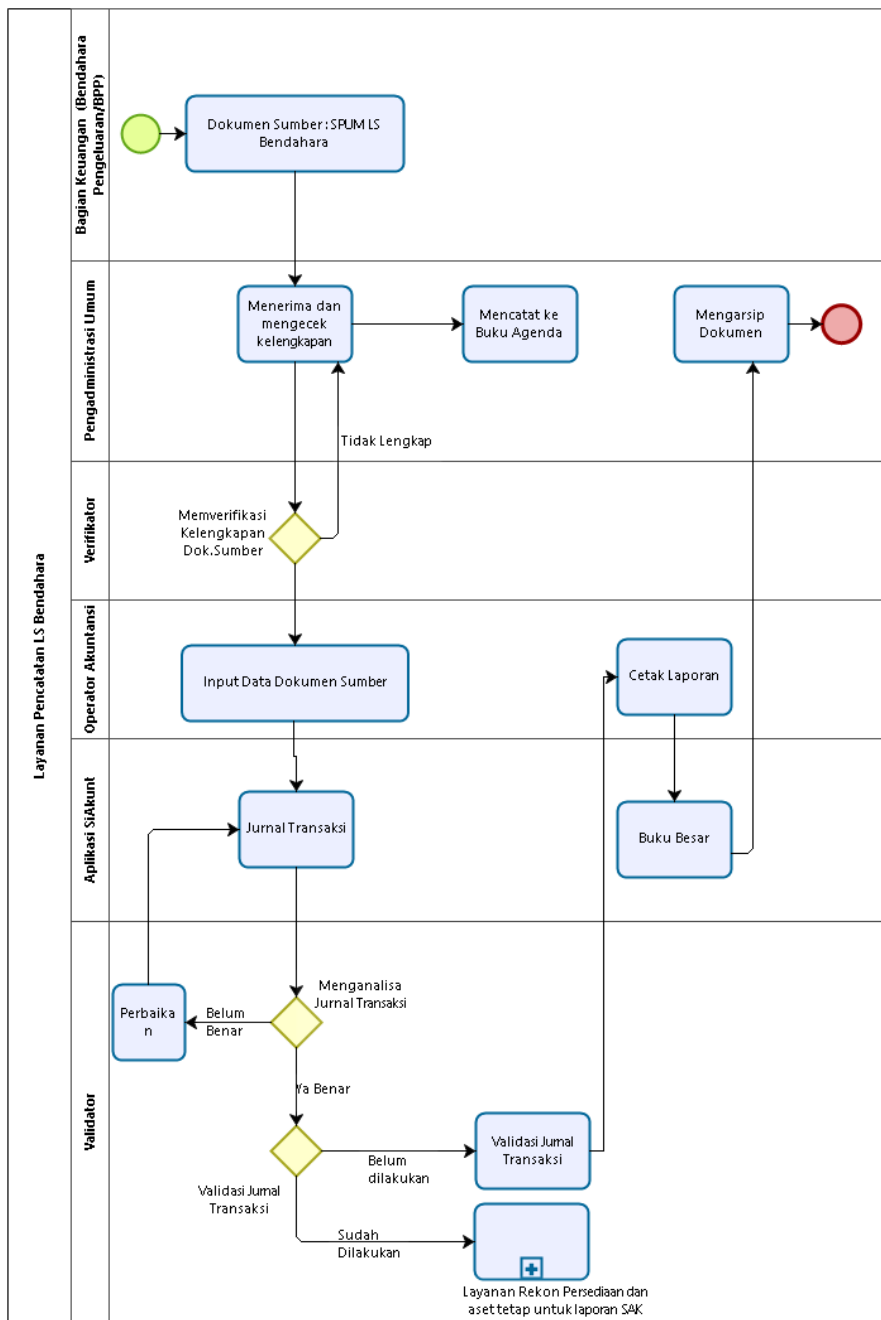

Level 5 Layanan Pencatatan LS Pegawai

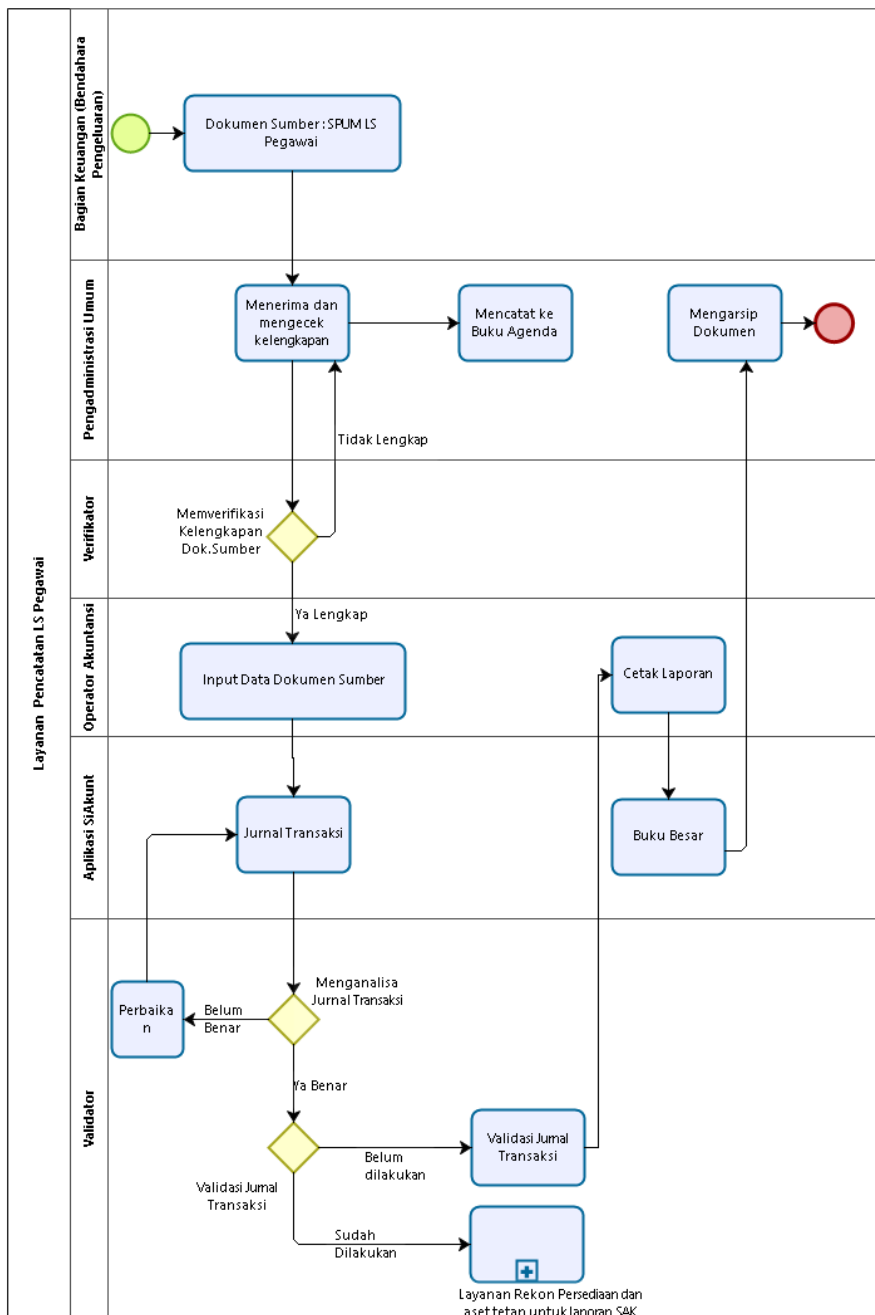

Level 5 Layanan Pencatatan LS Pihak Ketiga

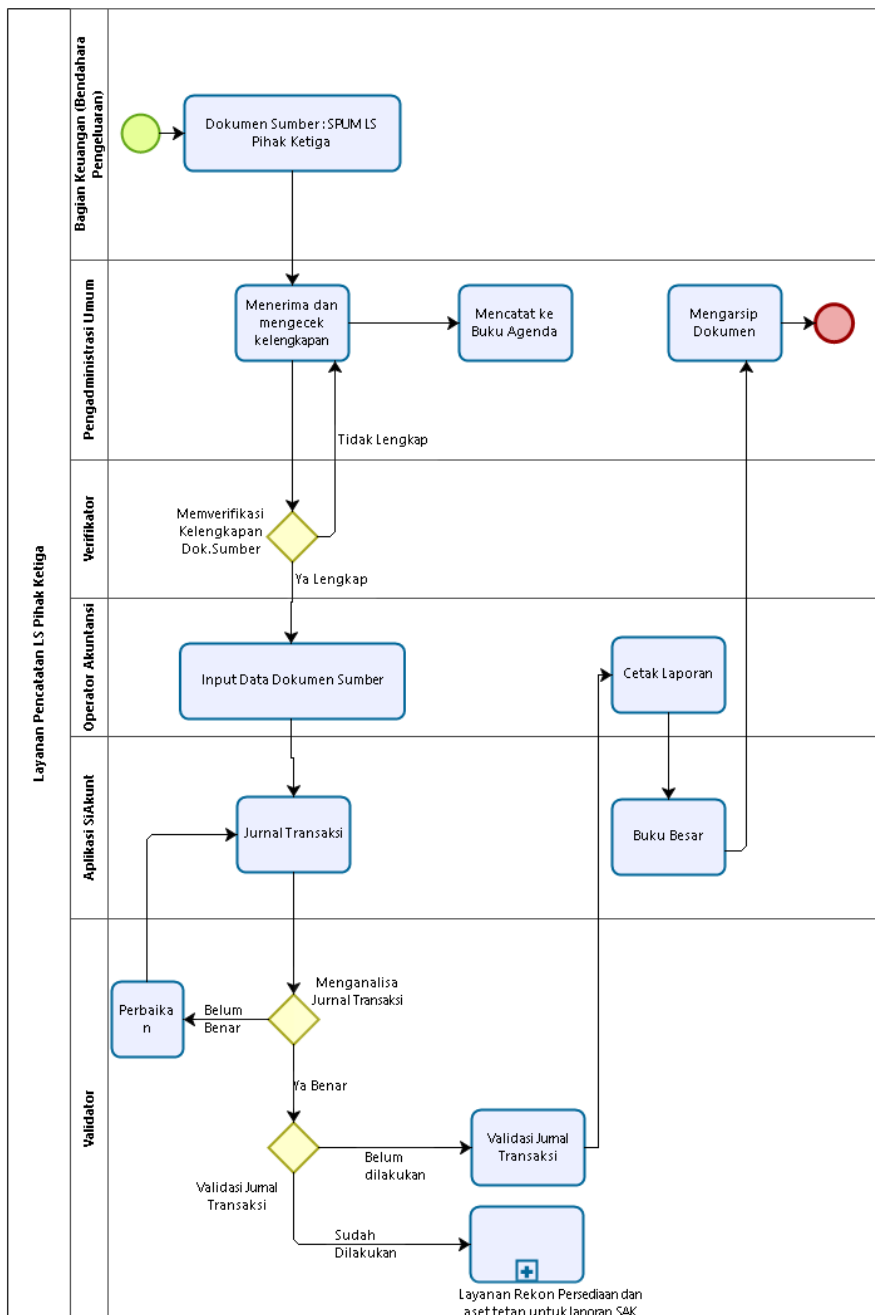

Level 4 Layanan Pencatatan Pembayaran dan Pertanggungjawaban Panjar Kerja LS Sumber Daya PNB

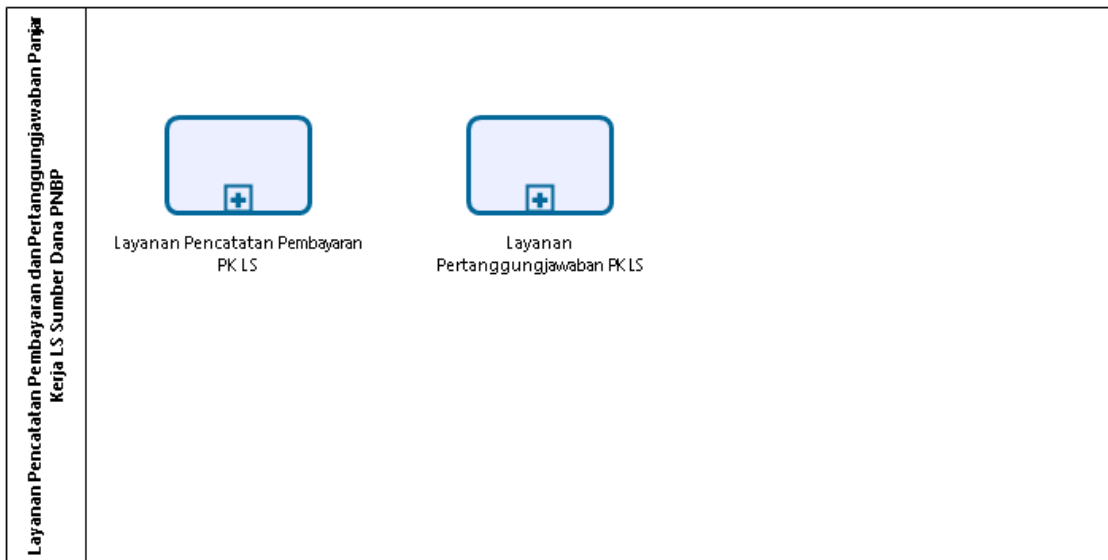

Level 5 Layanan Pencatatan Pembayaran PK LS

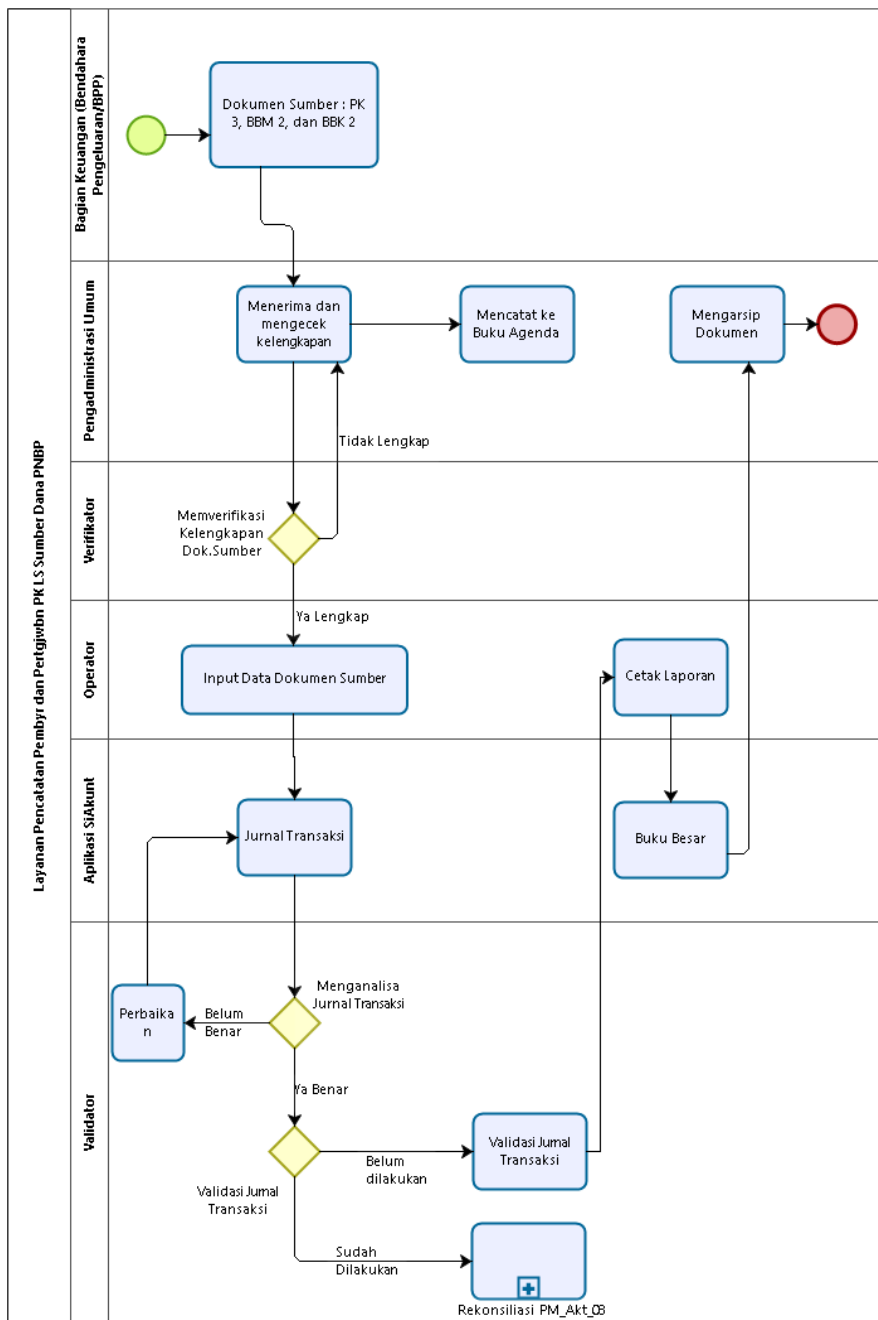

Level 5 Layanan Pertanggungjawaban PK LS

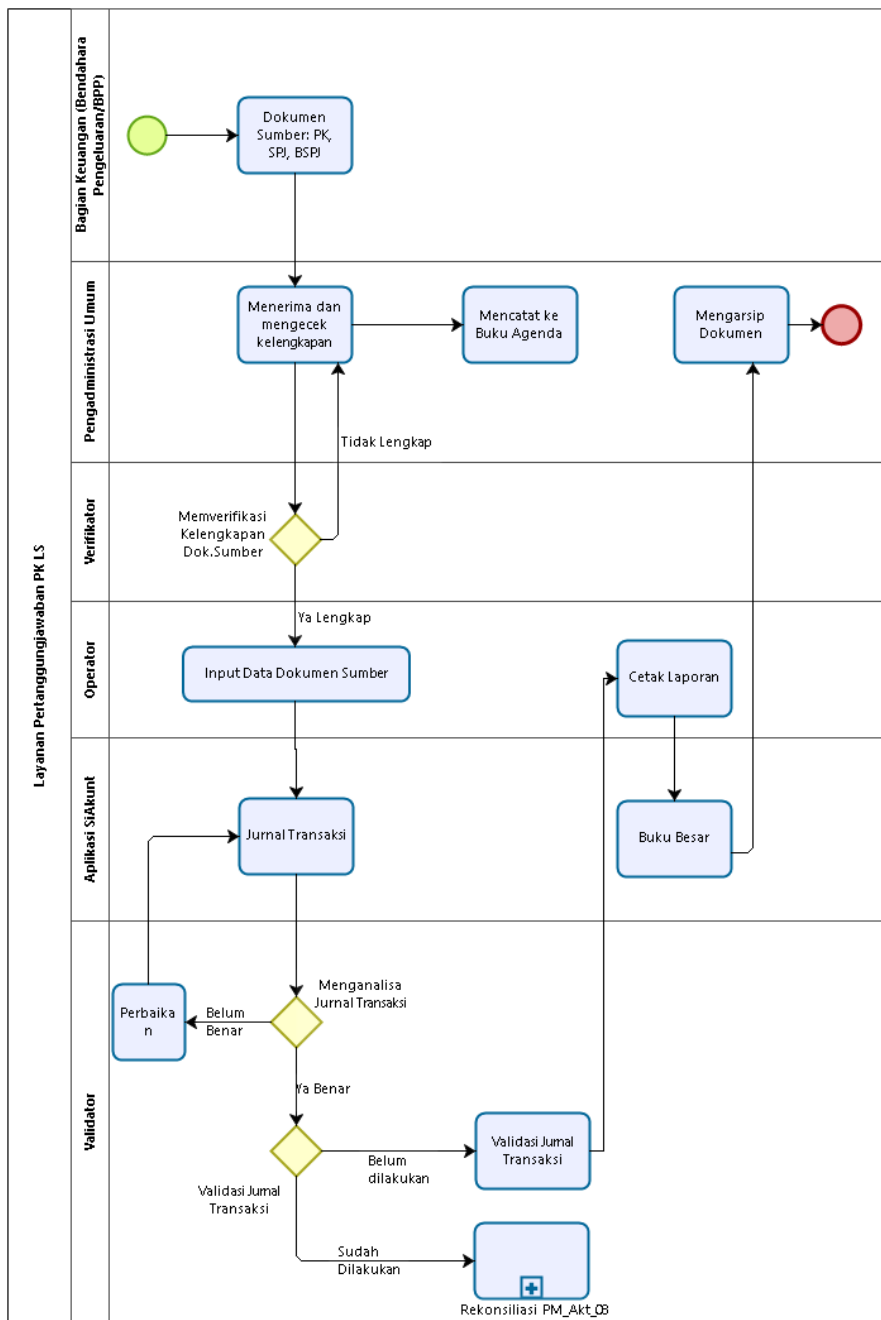

Level 4 Layanan Pencatatan SP2D dan SP3B

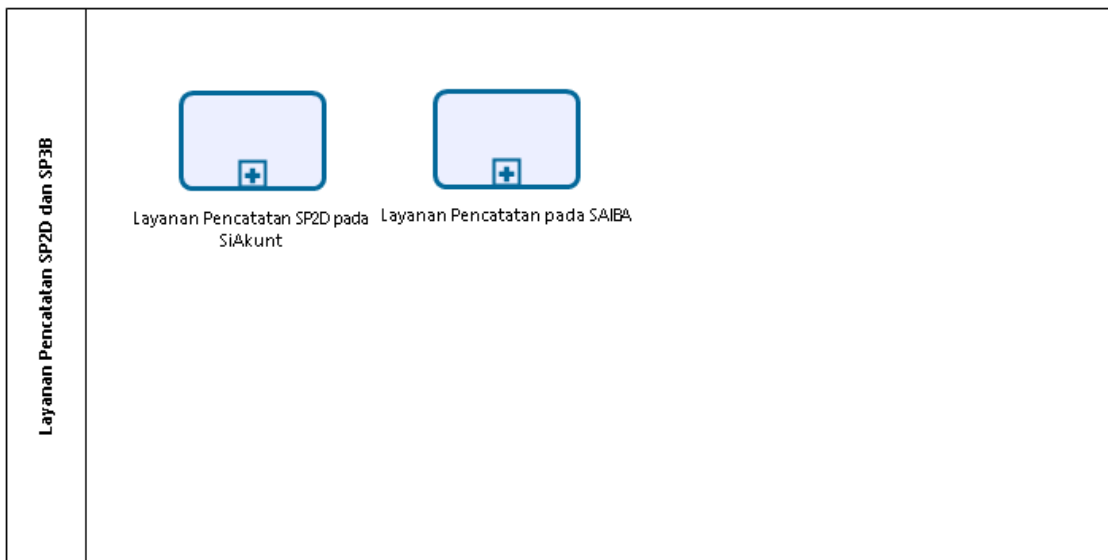

Level 5 Layanan Pencatatan SP2D dan SP3B

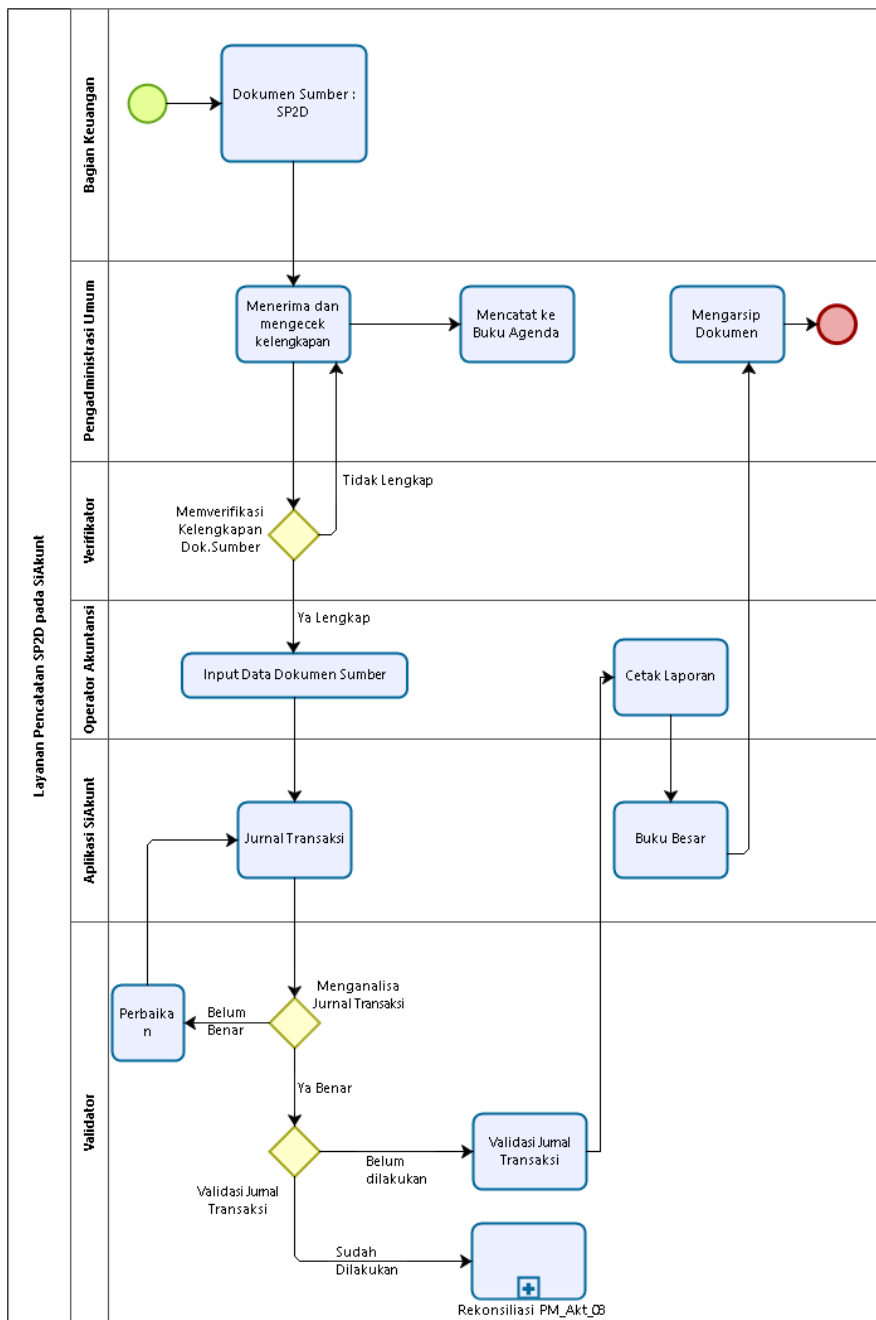

Level 5 Layanan Pencatatan pada SAIBA

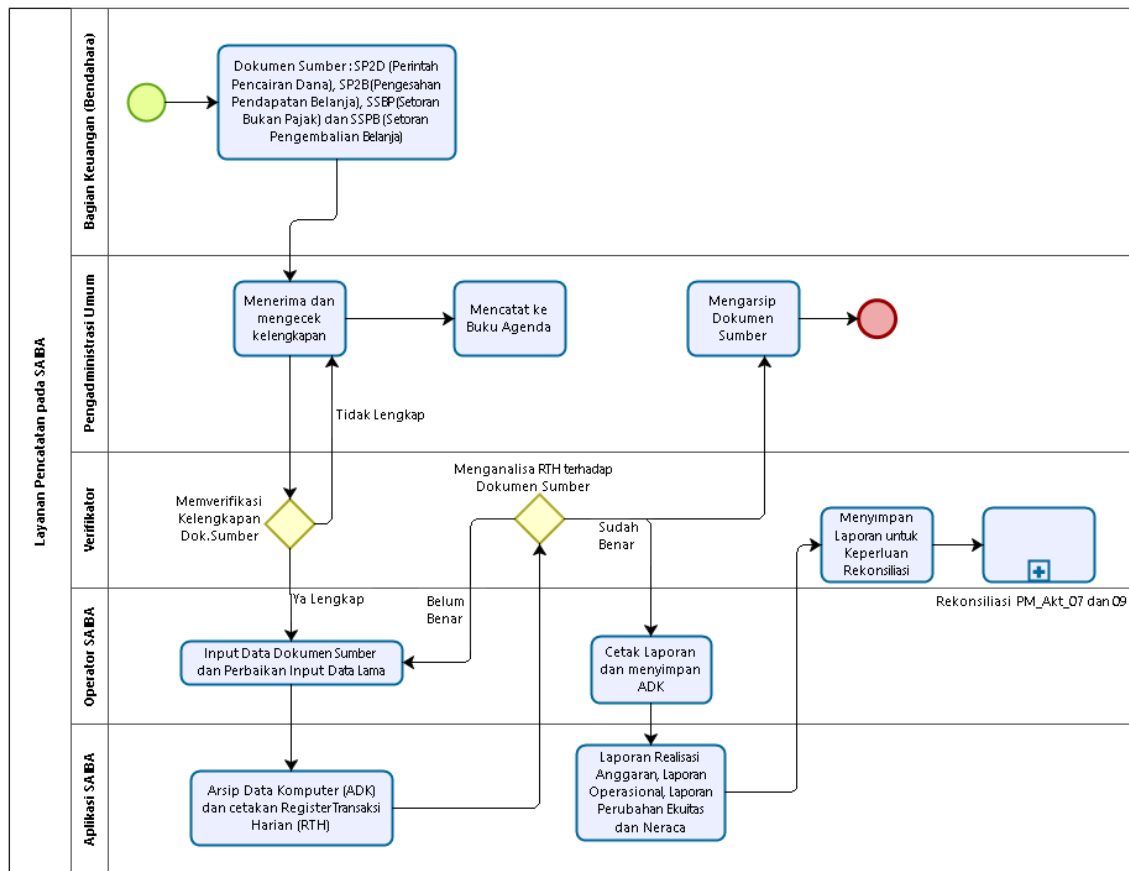

Level 4 Layanan Peminjaman Dokumen Pertanggungjawaban

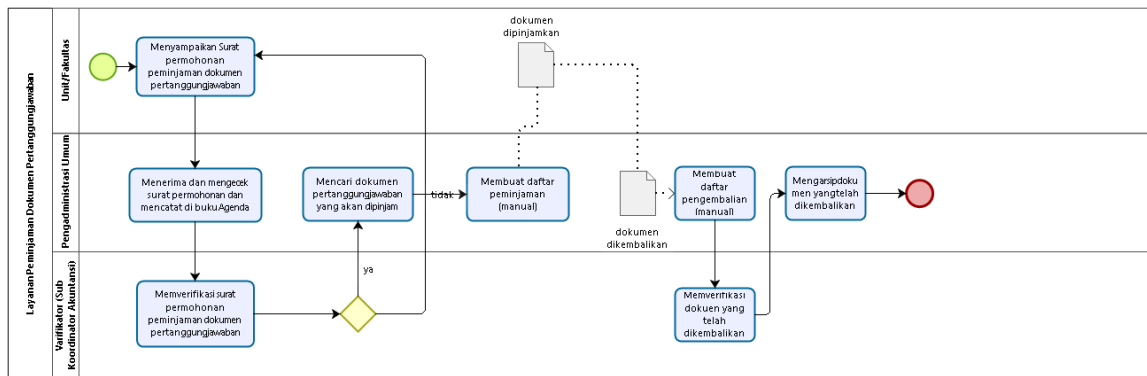

Level 4 Layanan Penerbitan Surat Keterangan Lanjutan

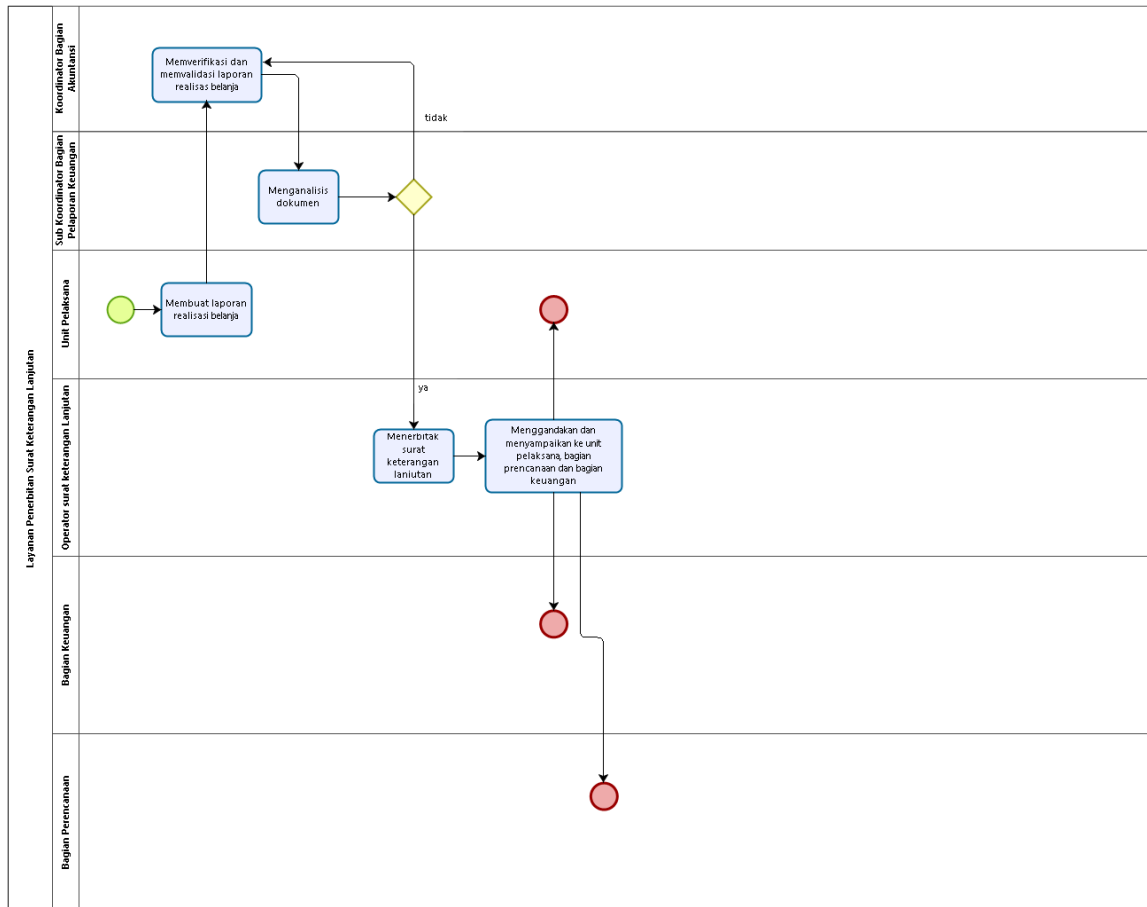

Level 4 Layanan Penerbitan Surat Keterangan Pengakuan Pendapatan Dana Kelolaan (DKA)

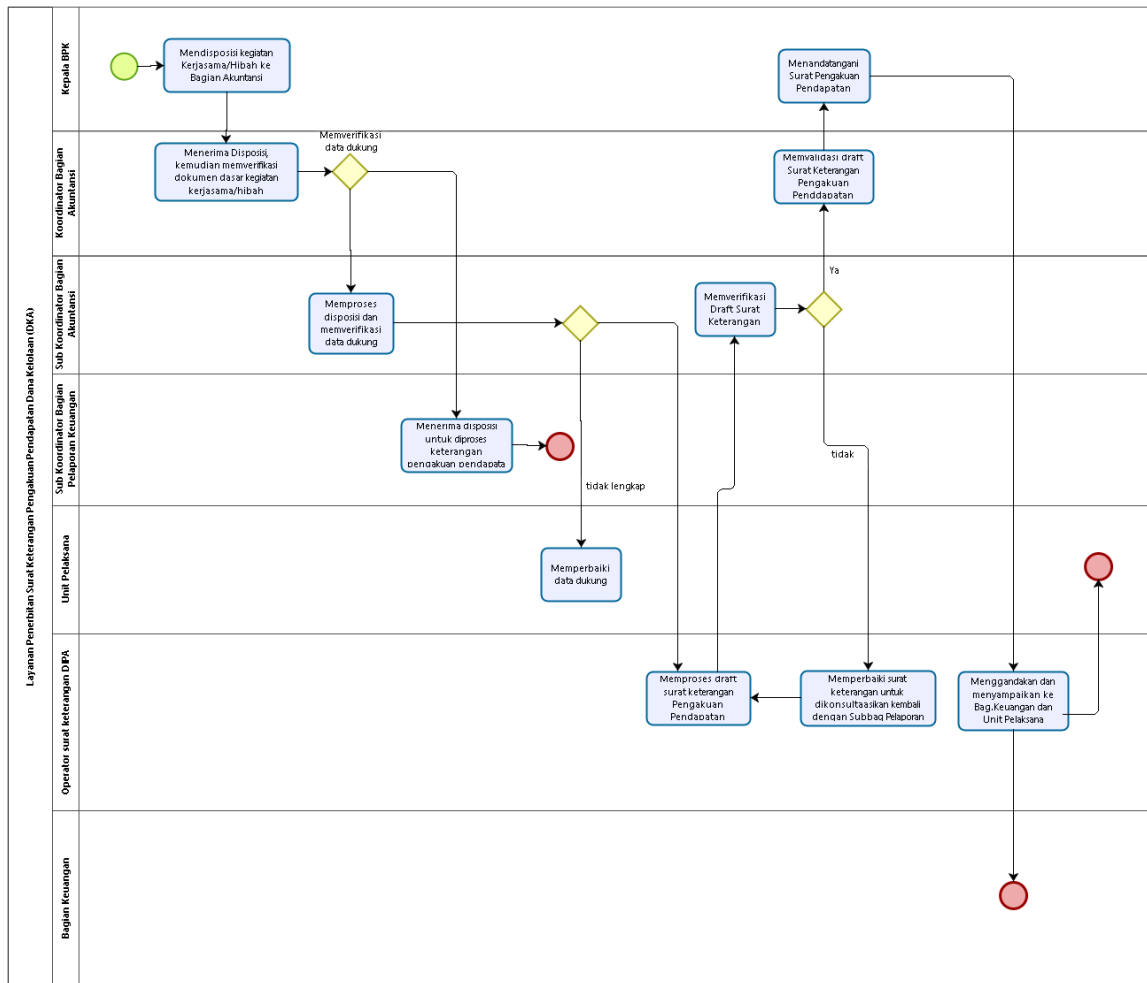

Level 4 Layanan Penerbitan Surat Keterangan Pengakuan Pendapatan (POK SUPLEMEN)

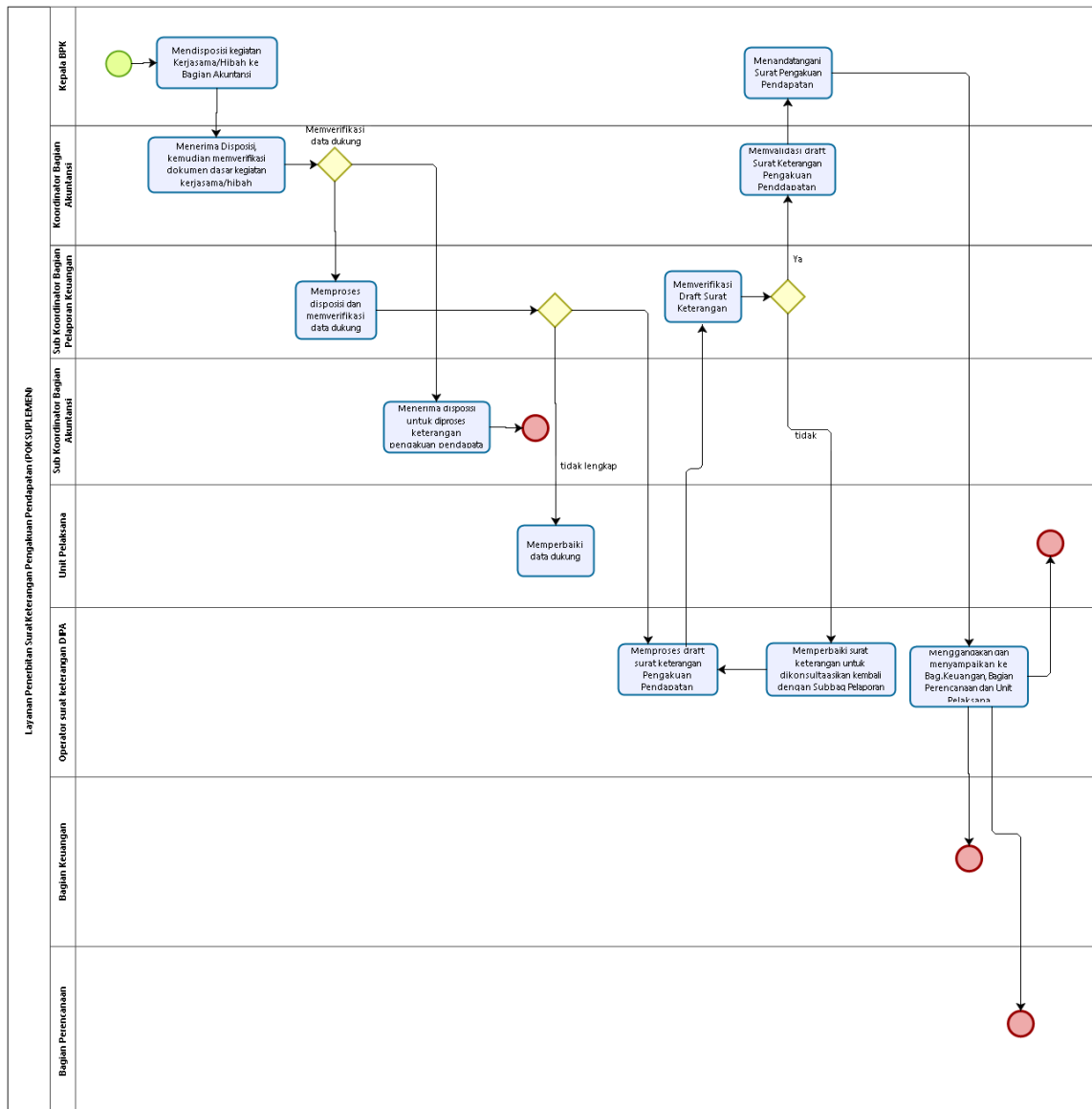

Level 3 Layanan Pelaporan Keuangan

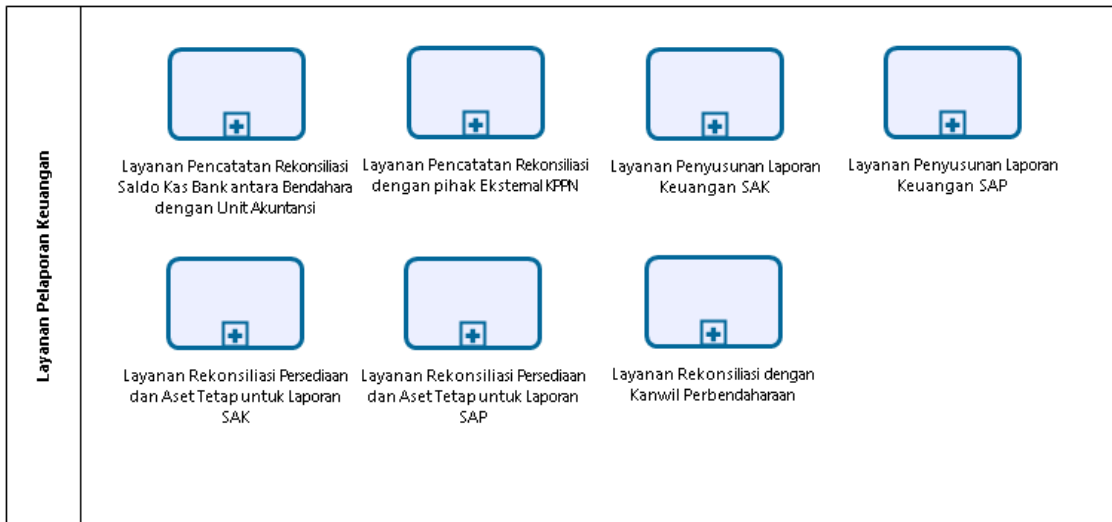

Level 4 Layanan Pencatatan Rekonsiliasi Saldo Kas Bank antara Bendahara dengan Unit Akuntansi

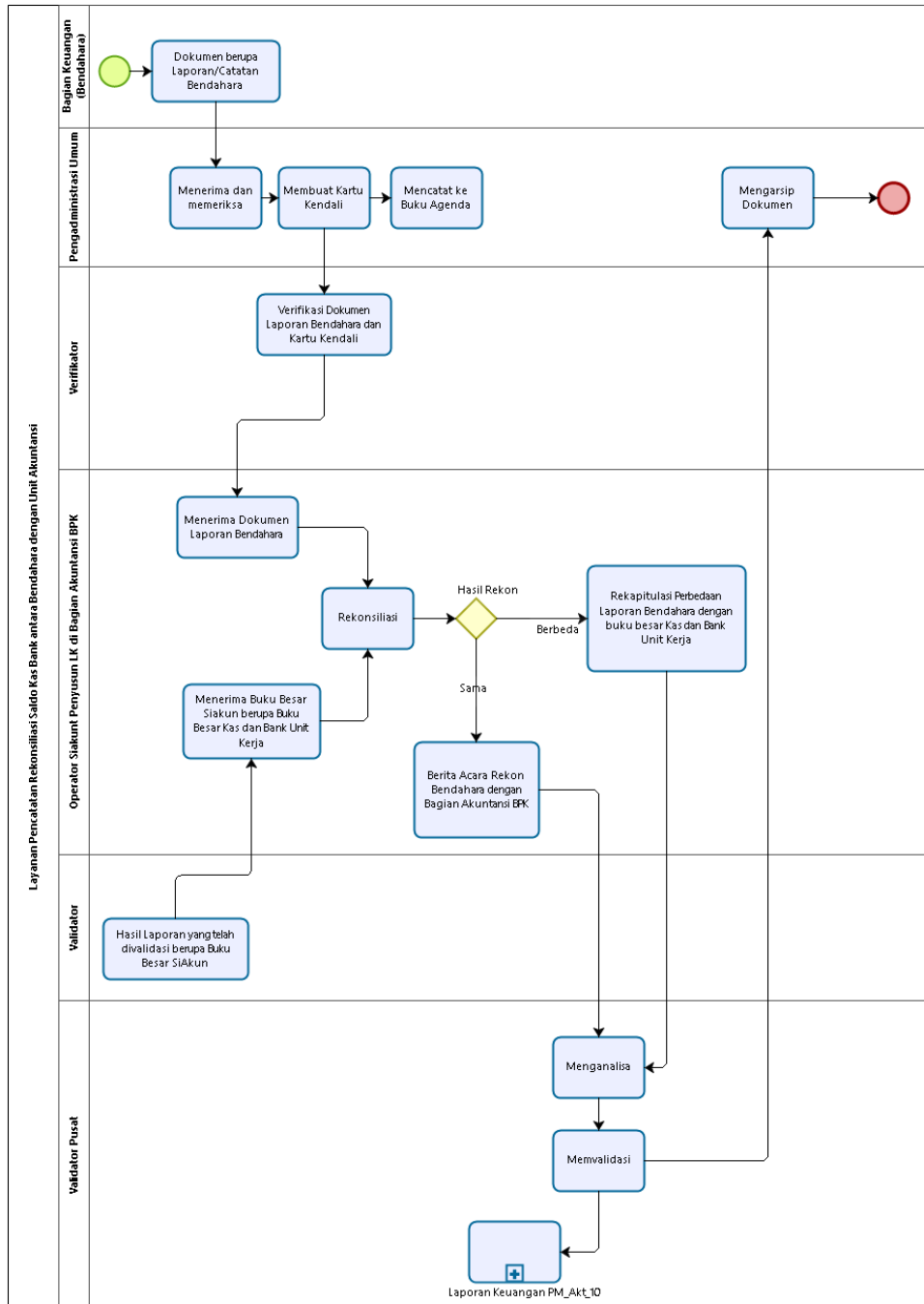

Level 4 Layanan Pencatatan Rekonsiliasi dengan Pihak Eksternal KPPN

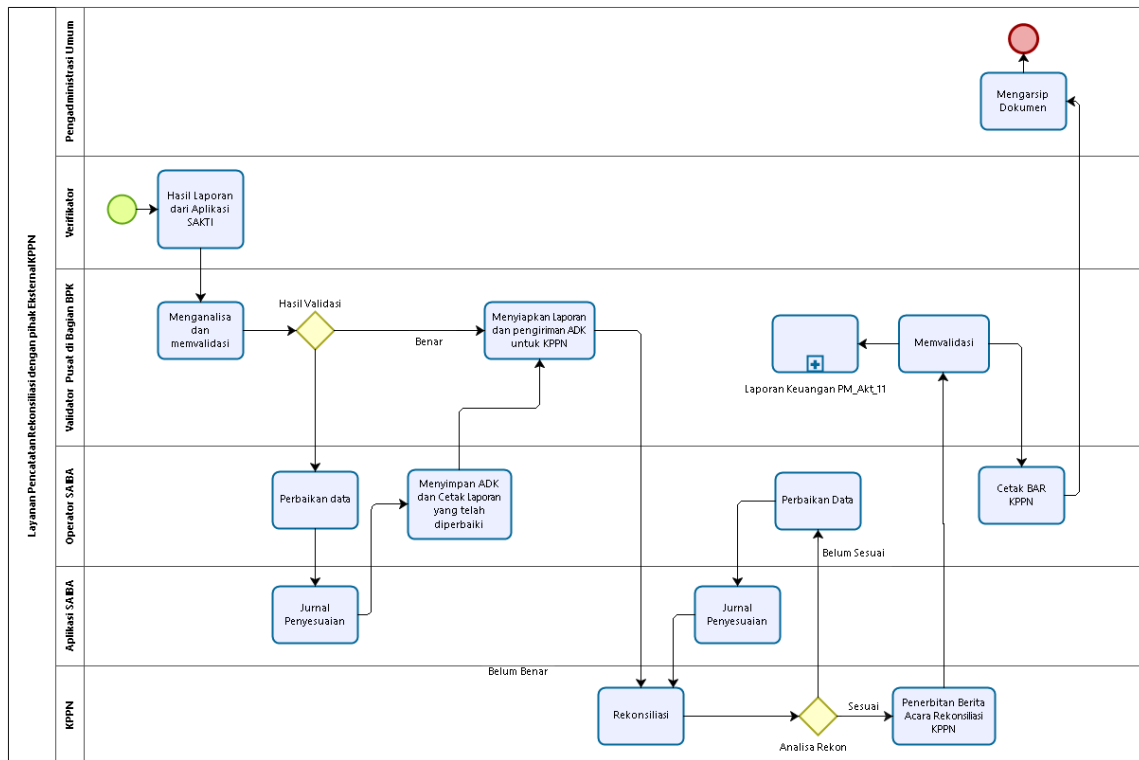

Powered by
bizagi
Modeler

Level 4 Layanan Penyusunan Laporan Keuangan SAK

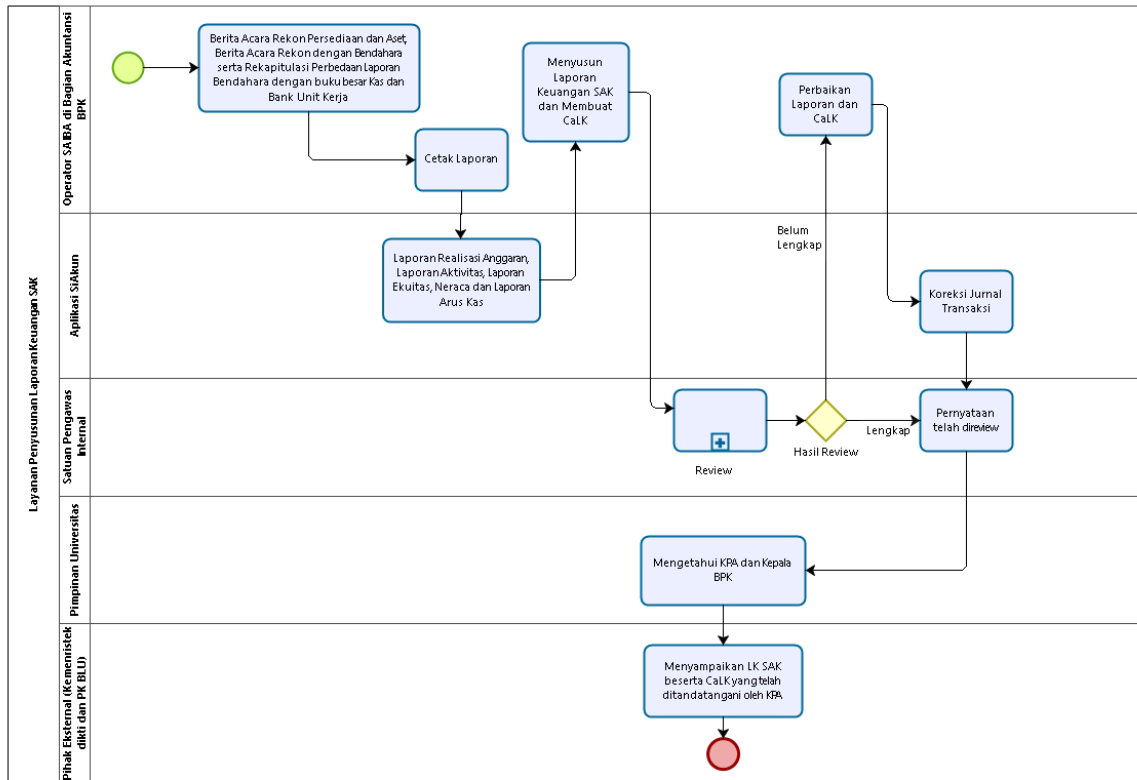

Level 4 Layanan Penyusunan Laporan Keuangan SAP

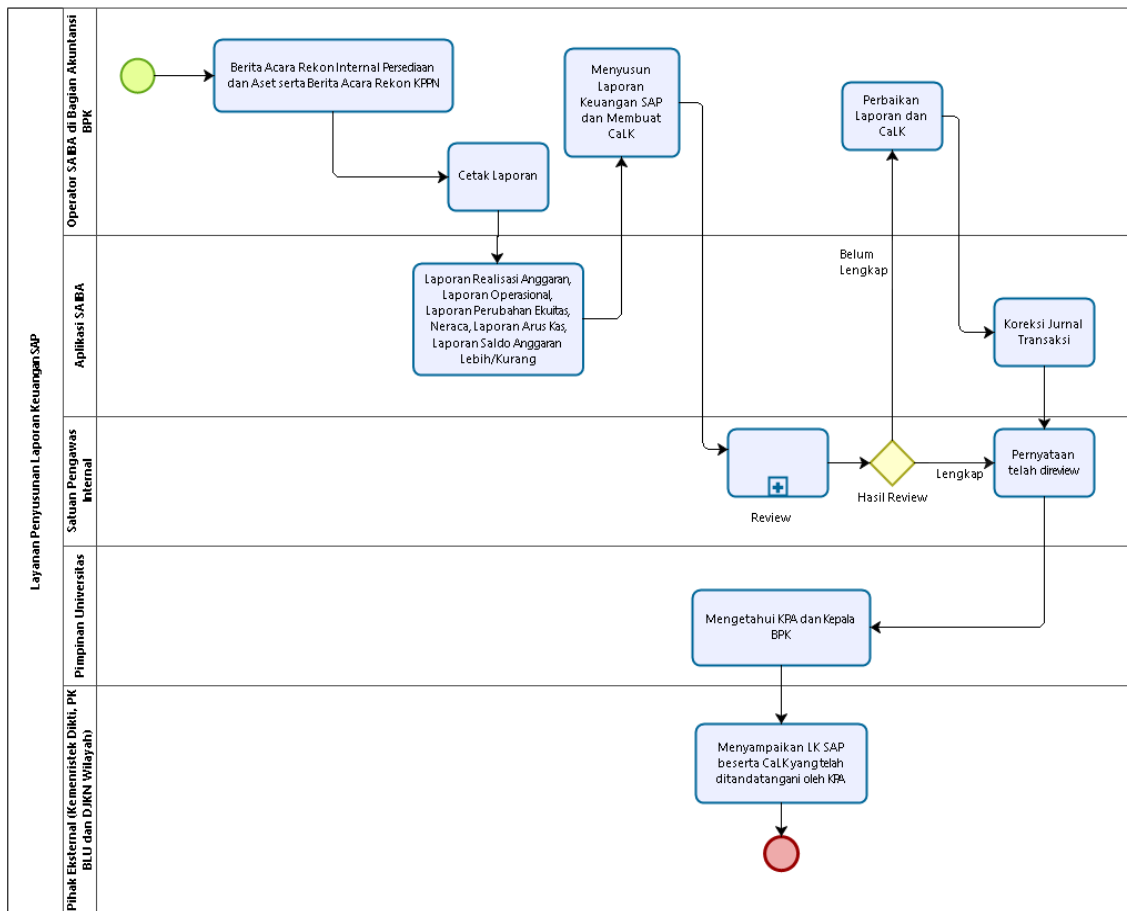

Level 4 Layanan Rekonsiliasi Persediaan dan Aset Tetap untuk Laporan SAK

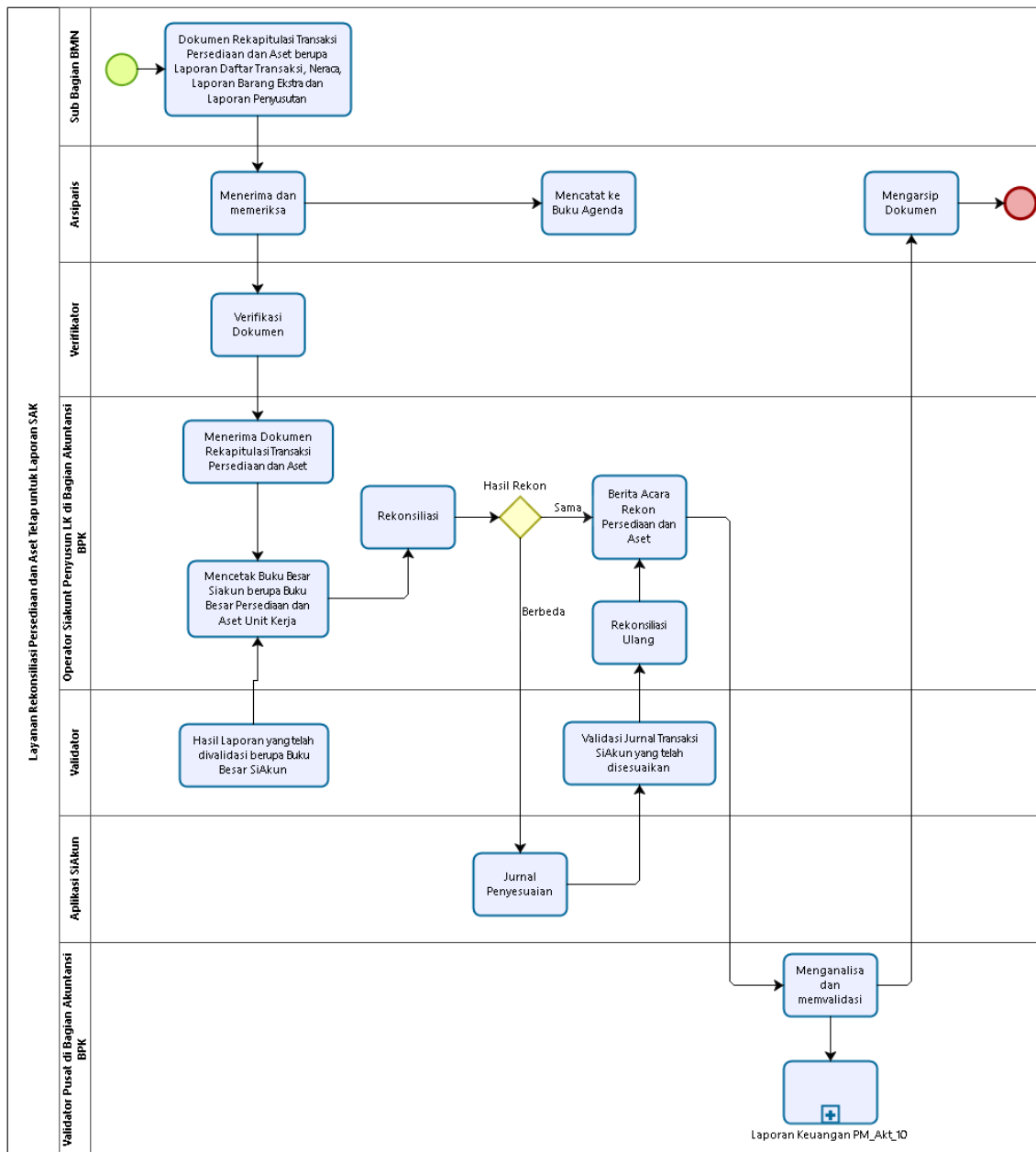

Level 4 Layanan Rekonsiliasi Persediaan dan Aset Tetap untuk Laporan SAP

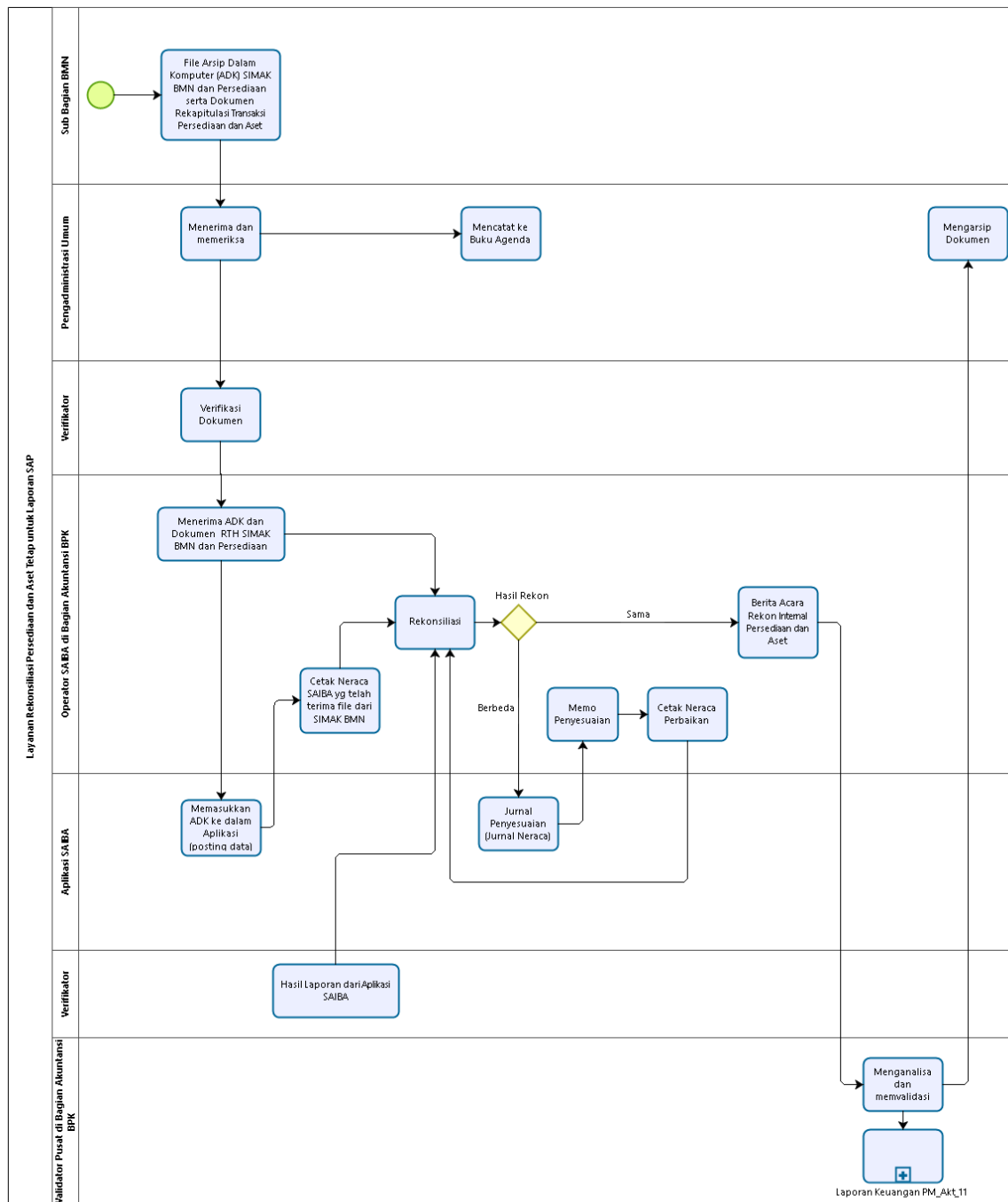

Level 4 Layanan Rekonsiliasi dengan Kanwil Perbendaharaan

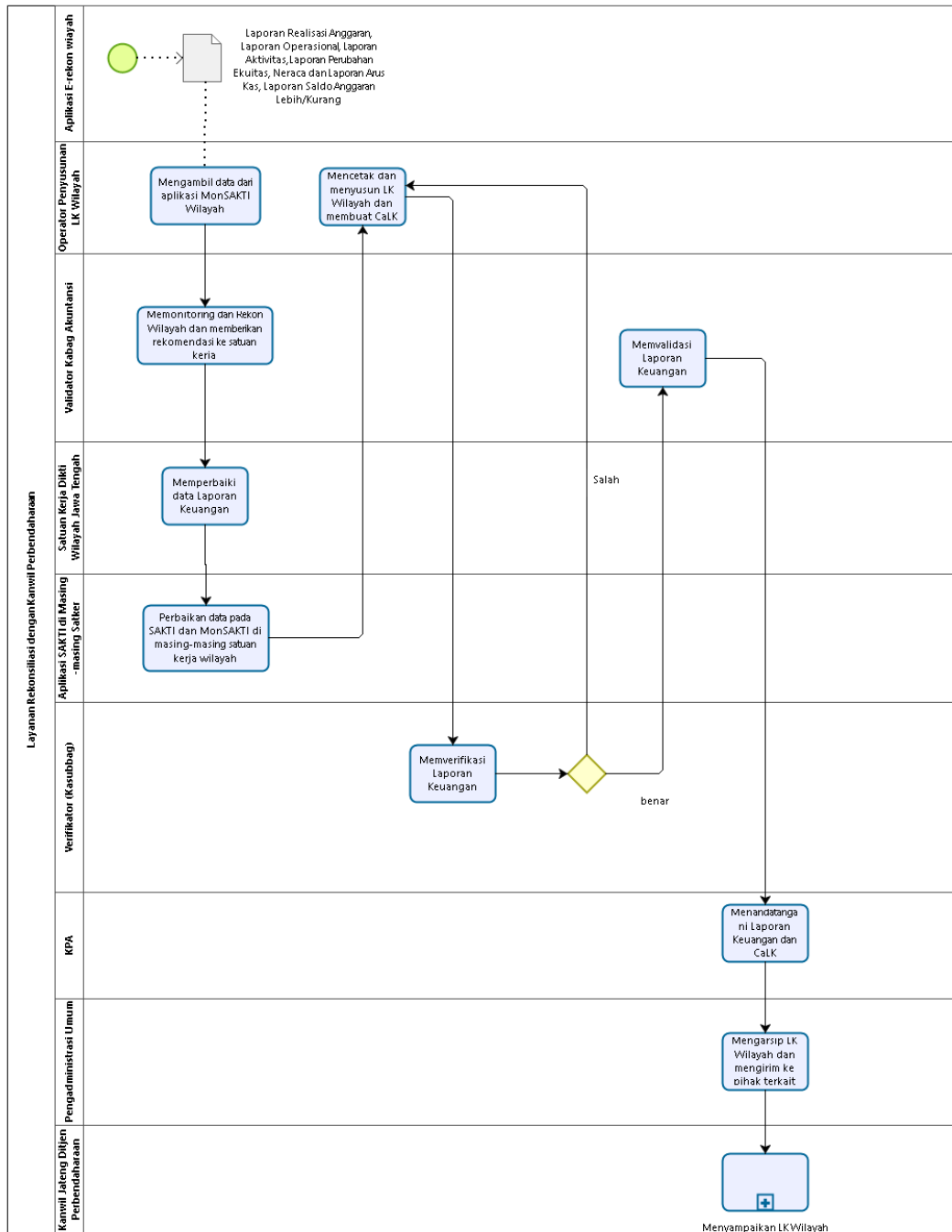

Level 1 Layanan Perpustakaan



Powered by
bizagi
Modeler

Level 2 Layanan Peminjaman

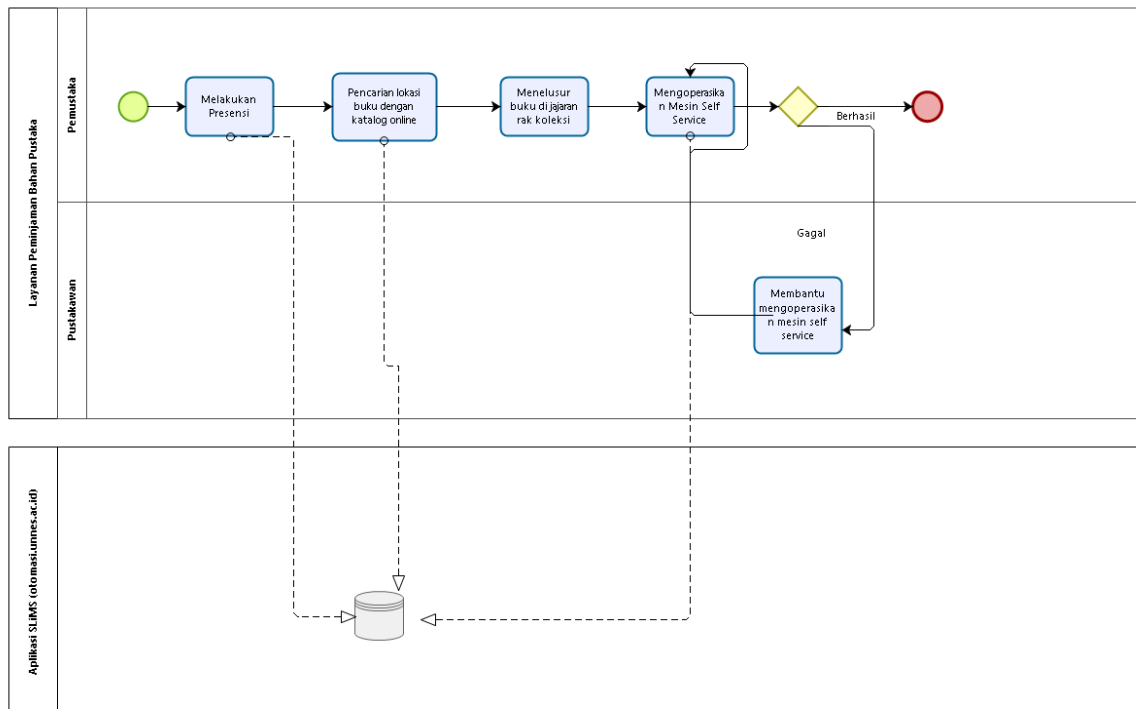

Powered by
bizagi
Modeler

Level 2 Layanan Pengembalian

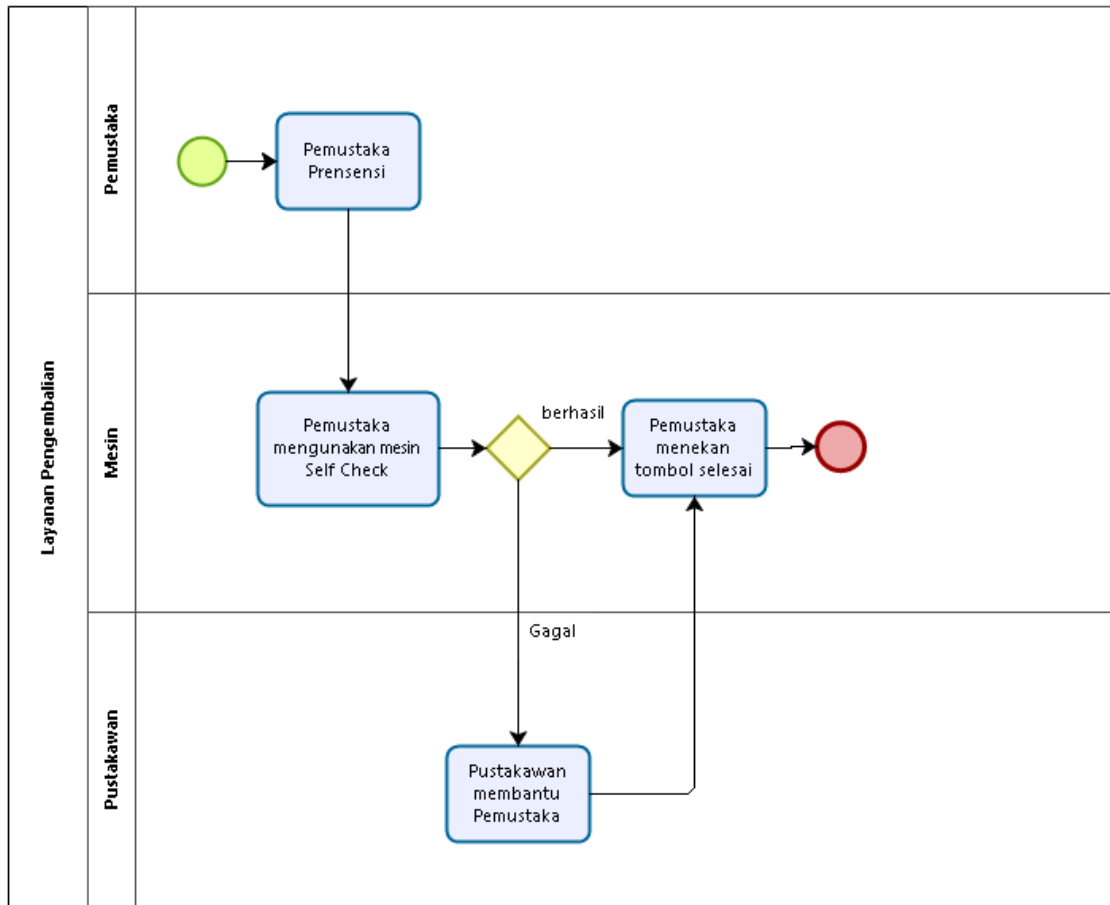

Level 2 Layanan Perpanjangan

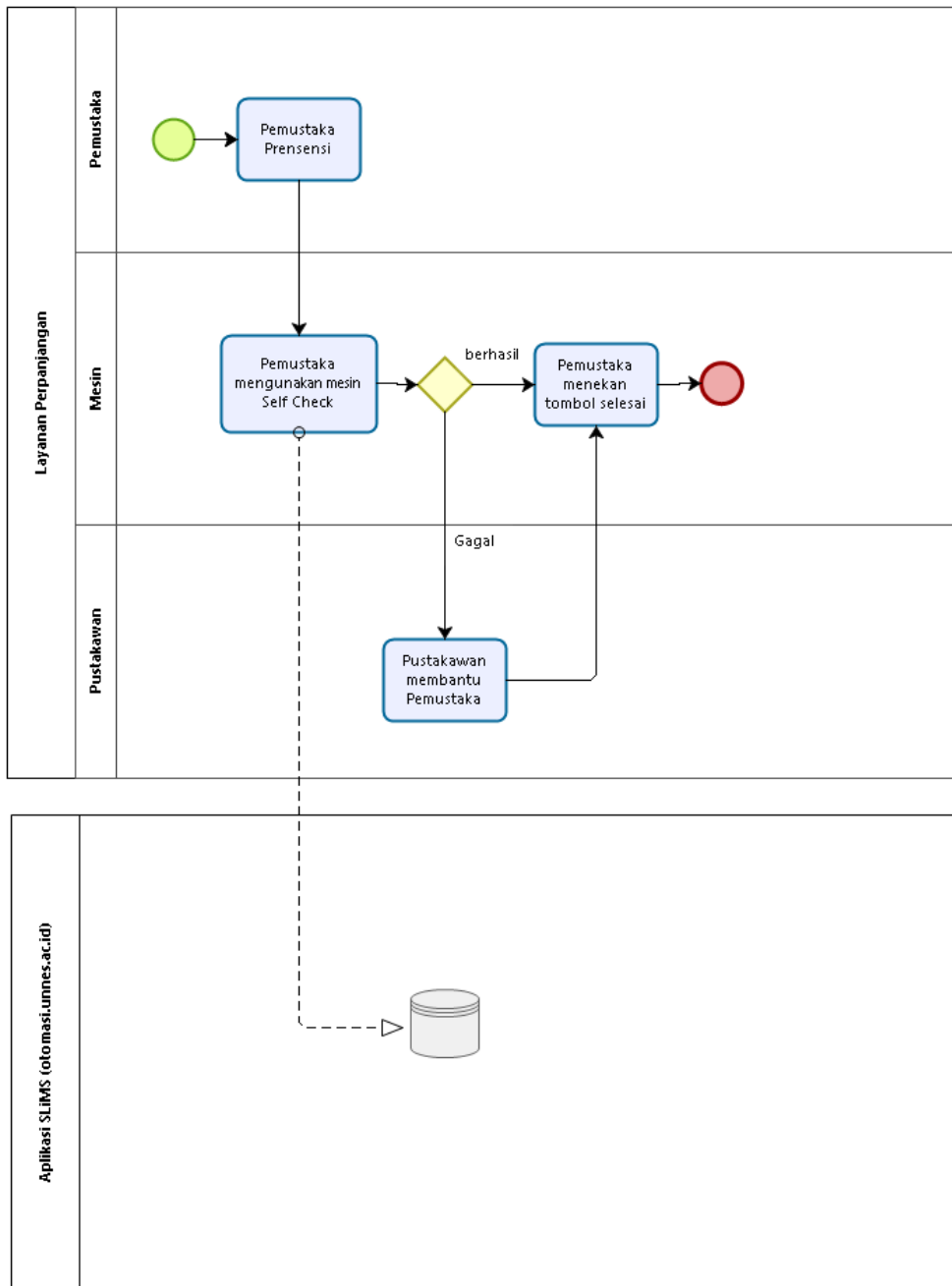

Level 2 Layanan Bebas Perpustakaan

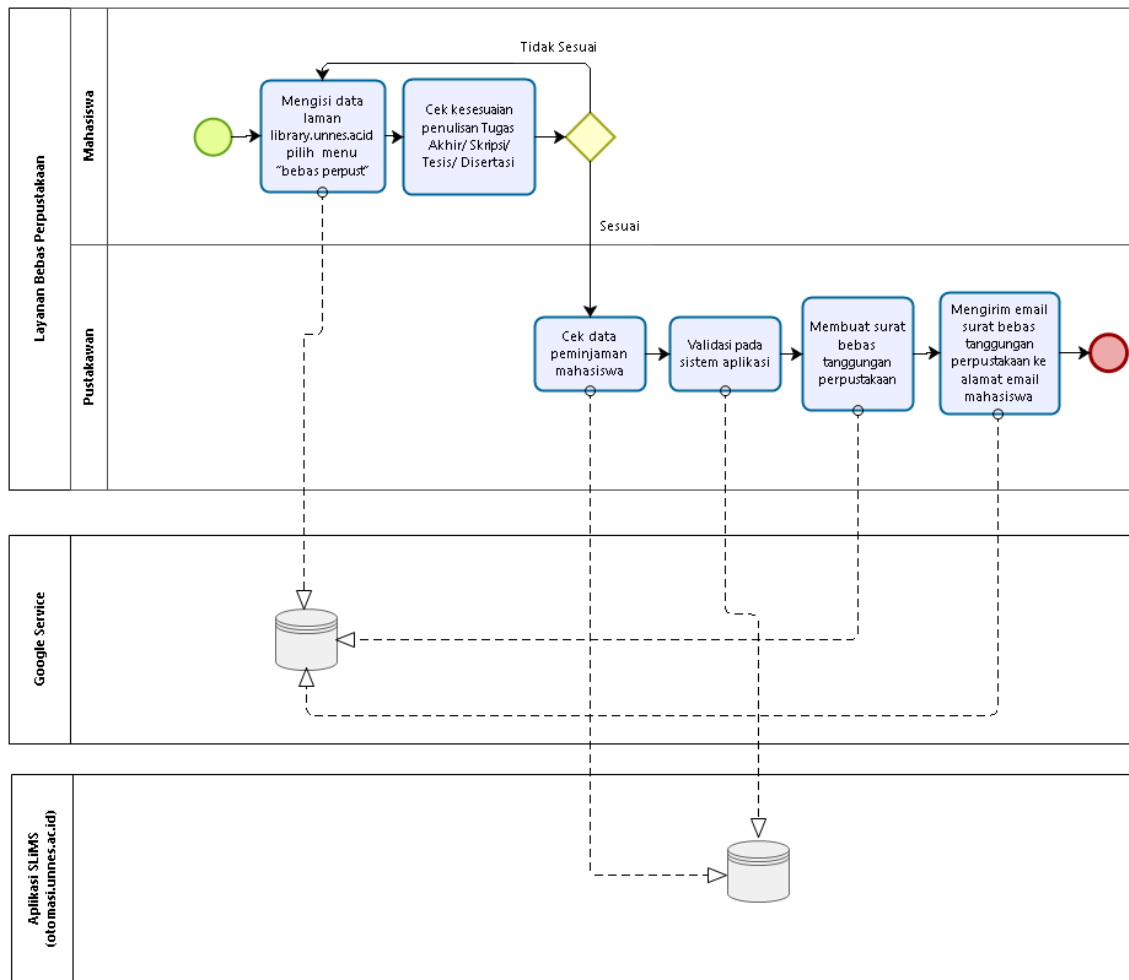

Level 2 Layanan Keterangan KTD

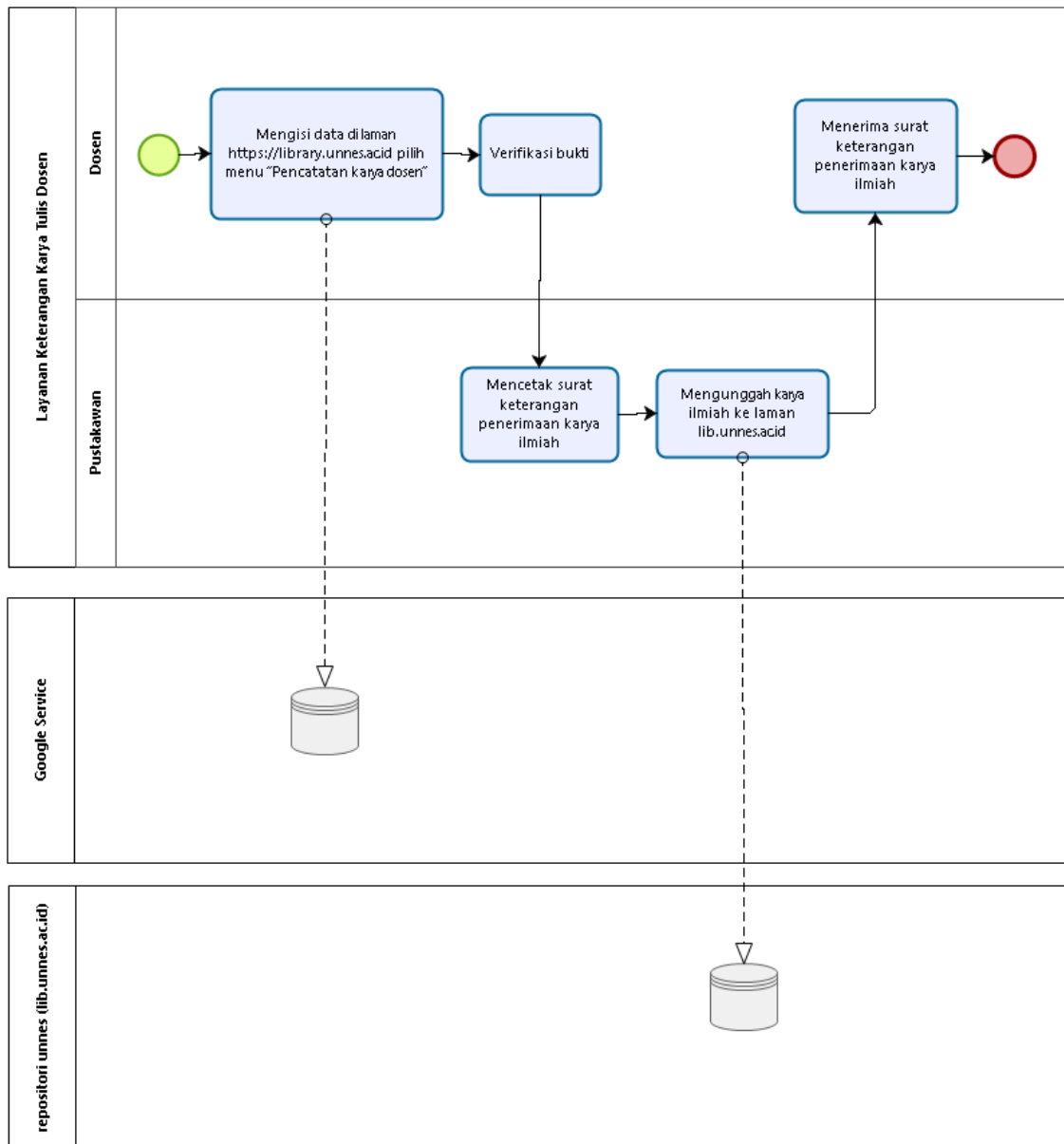

Level 2 Layanan Uji Turnitin

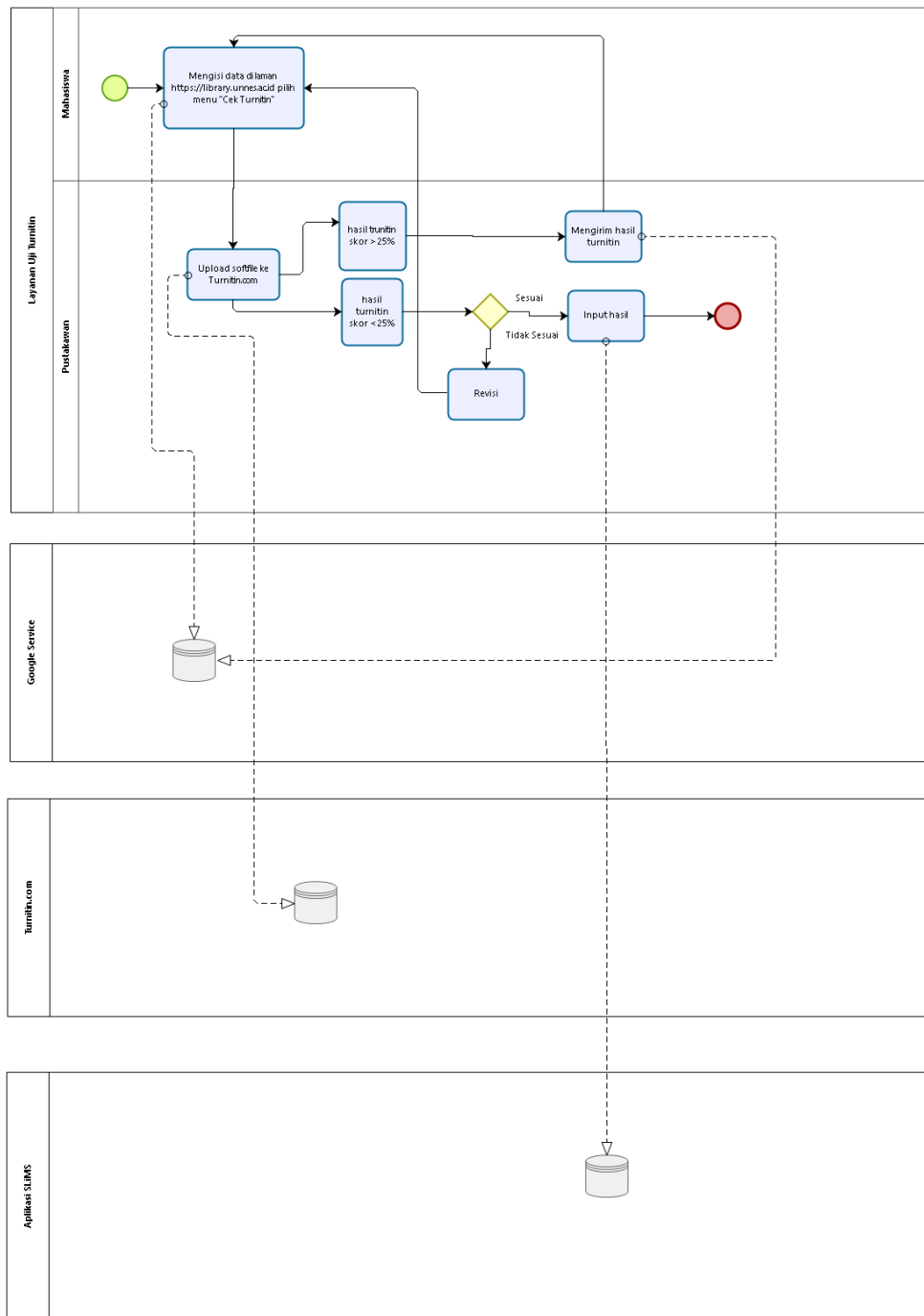

Powered by
bizagi
Modeler

Level 2 Layanan Pengolahan Buku

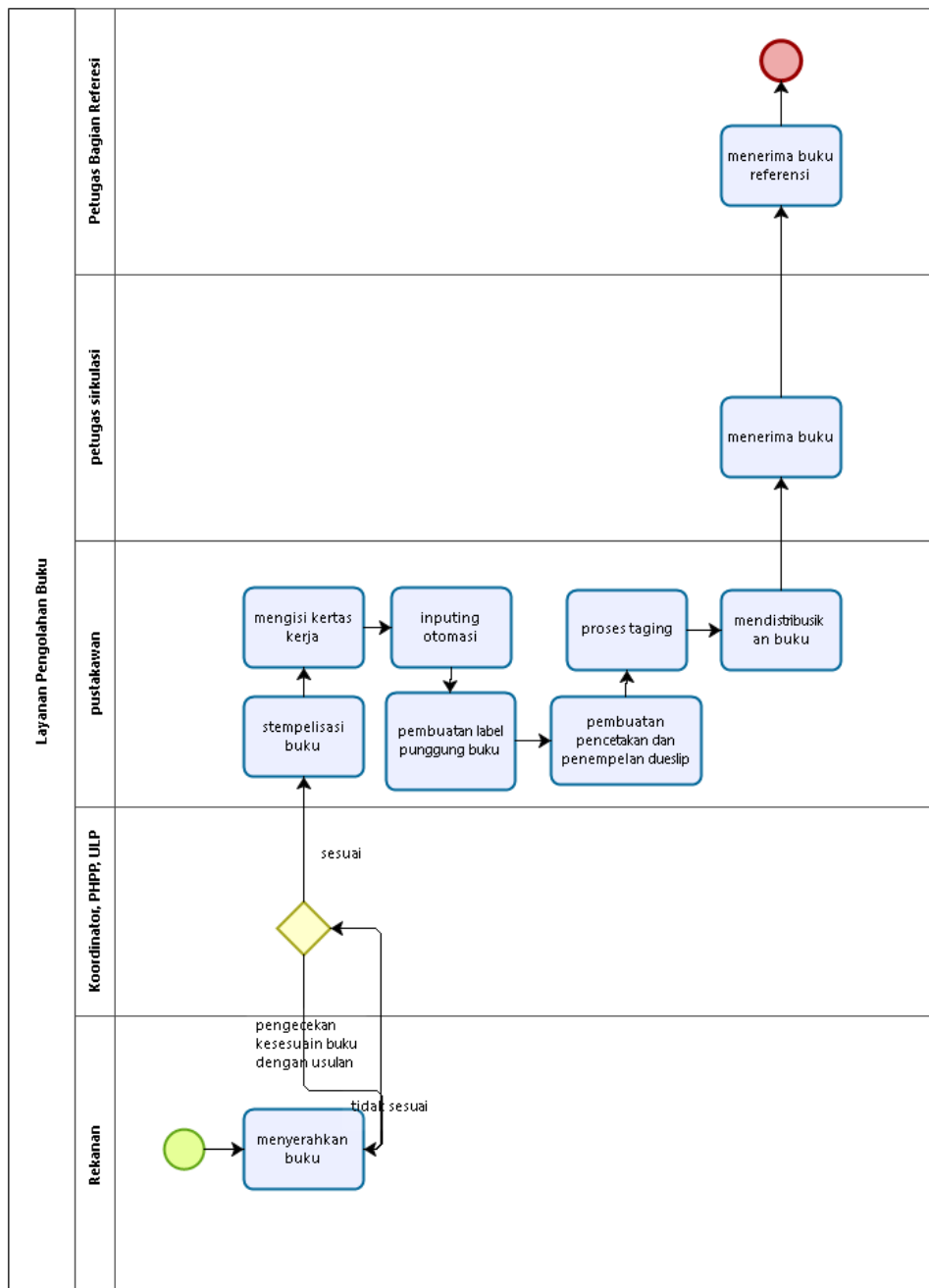

Level 1 Layanan Teknologi Informasi dan Komunikasi

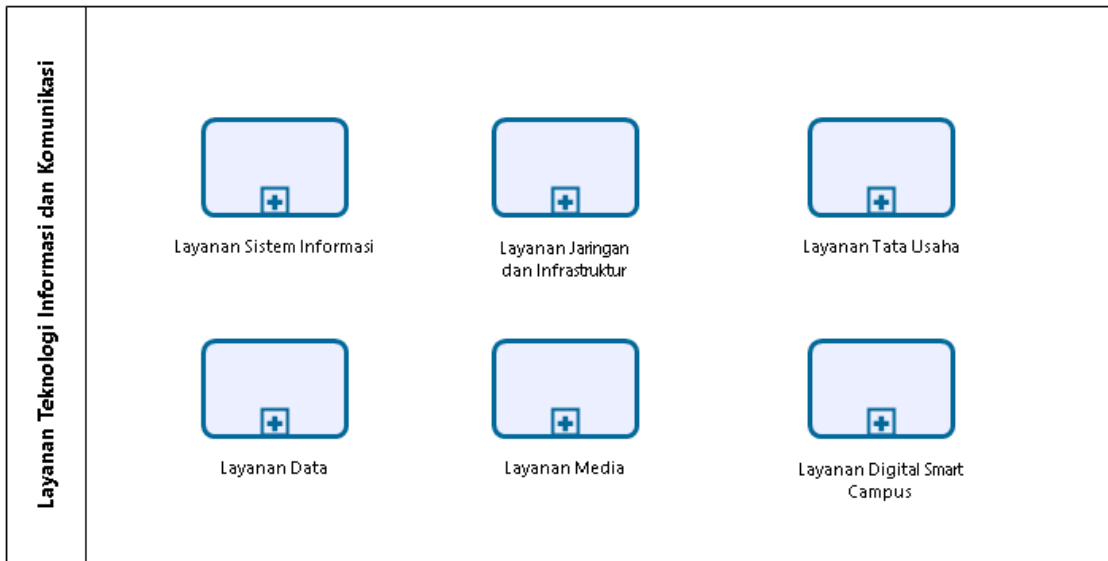

Powered by
bizagi
Modeler

Level 2 Layanan Sistem Informasi



Powered by
bizagi
Modeler

Level 3 Layanan Pembuatan Aplikasi

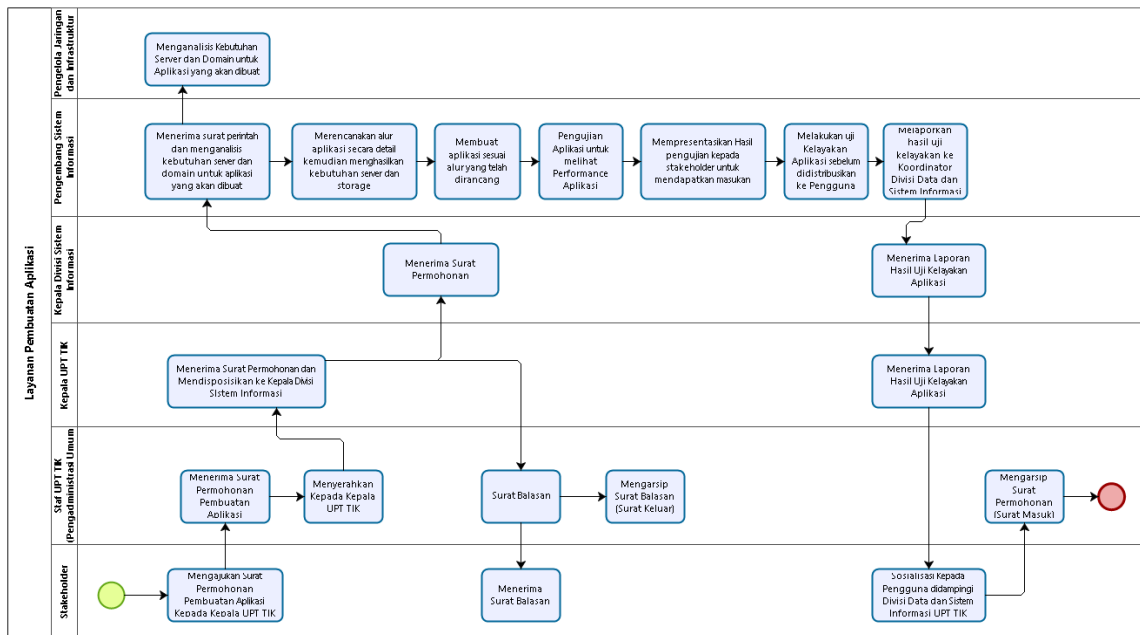

Powered by
bizagi
Modeler

Level 3 Layanan Web Hosting

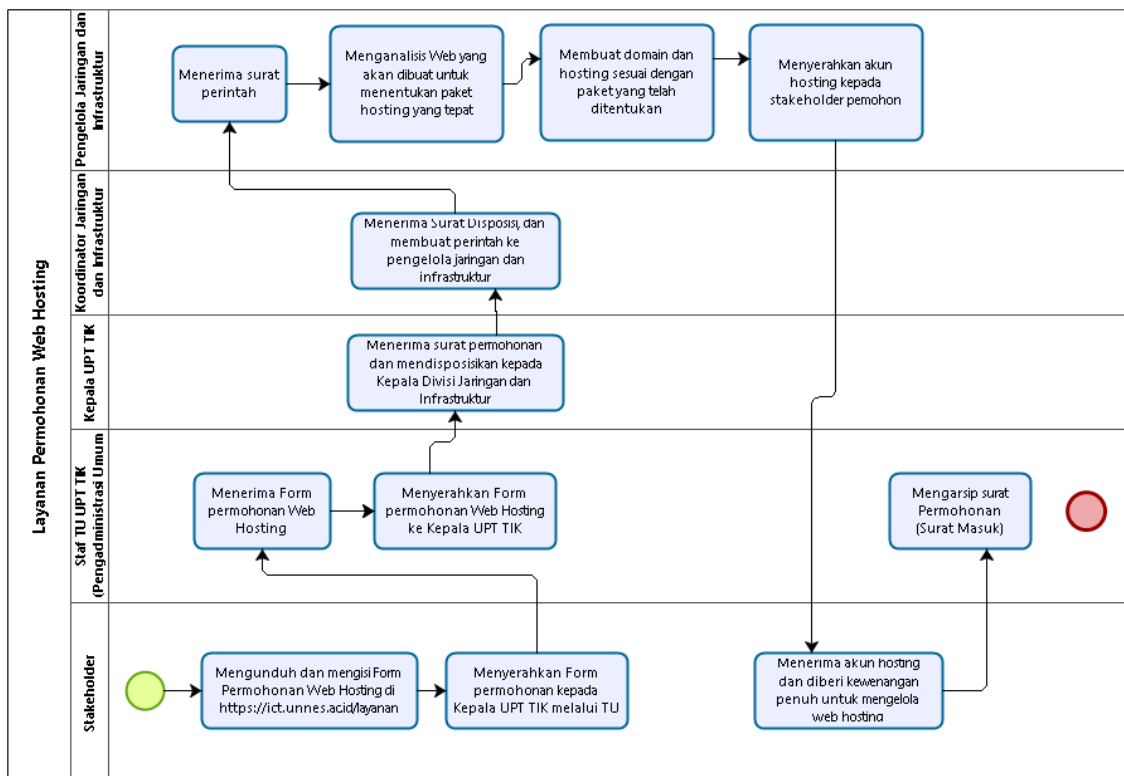

Powered by
bizagi
Modeler

Level 3 Layanan Pemeliharaan Website

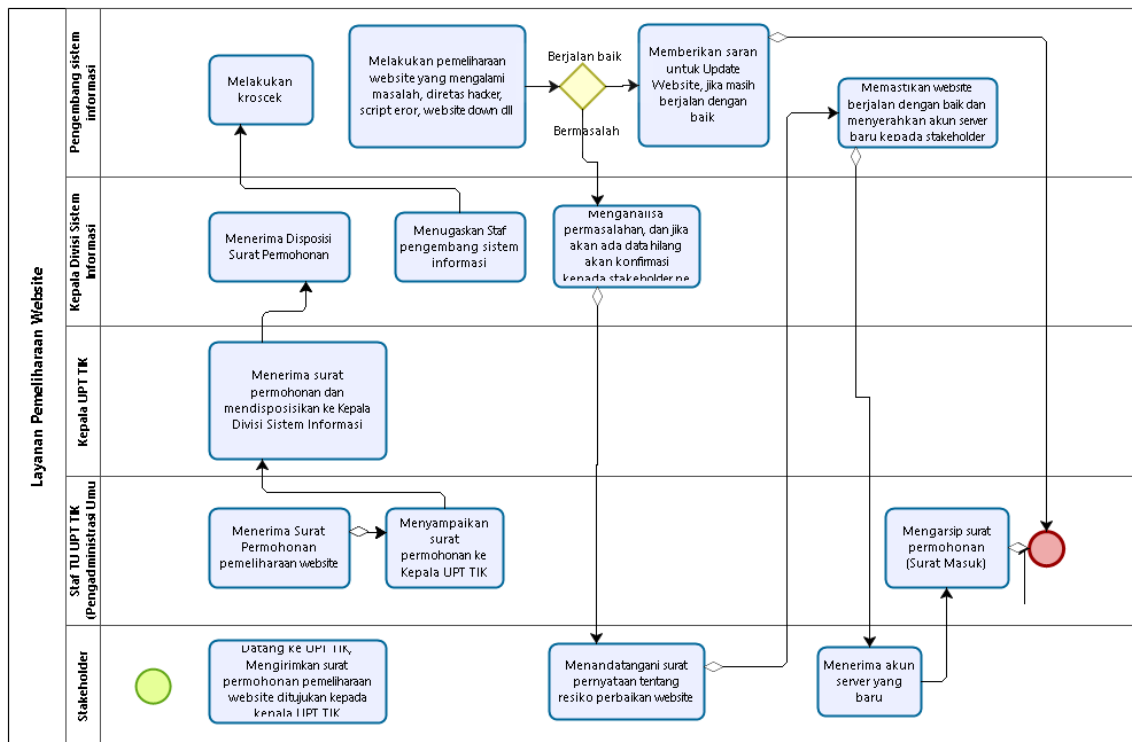

Level 3 Layanan Aplikasi Android

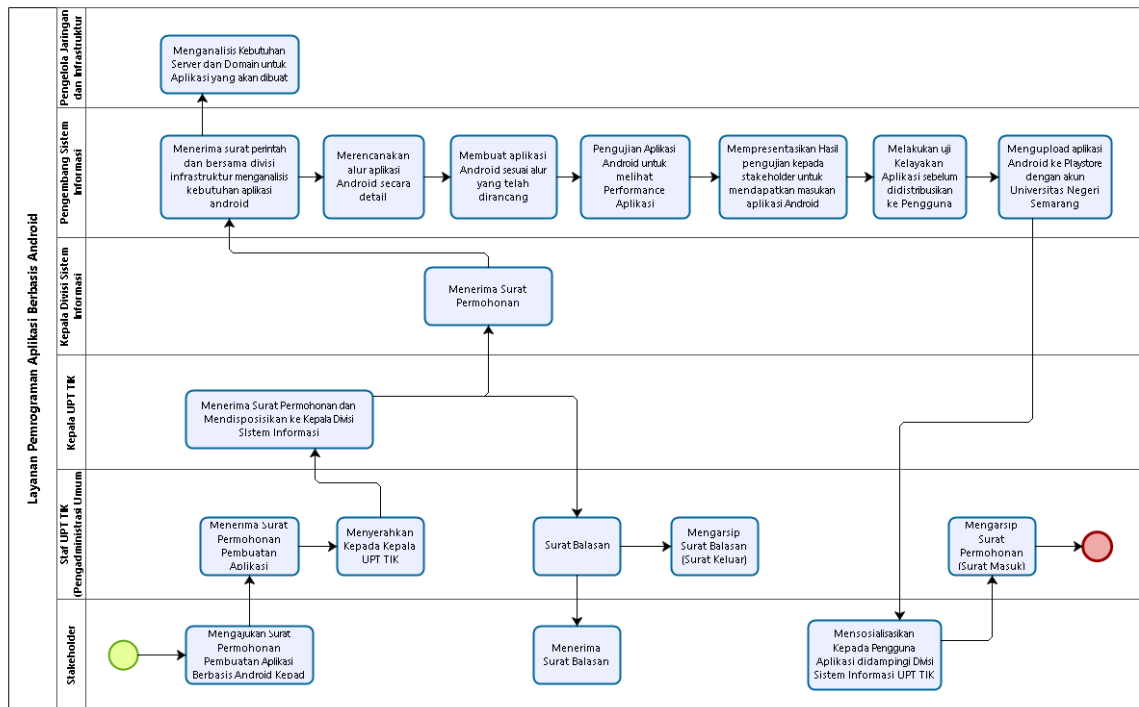

Level 3 Layanan Aplikasi Desktop

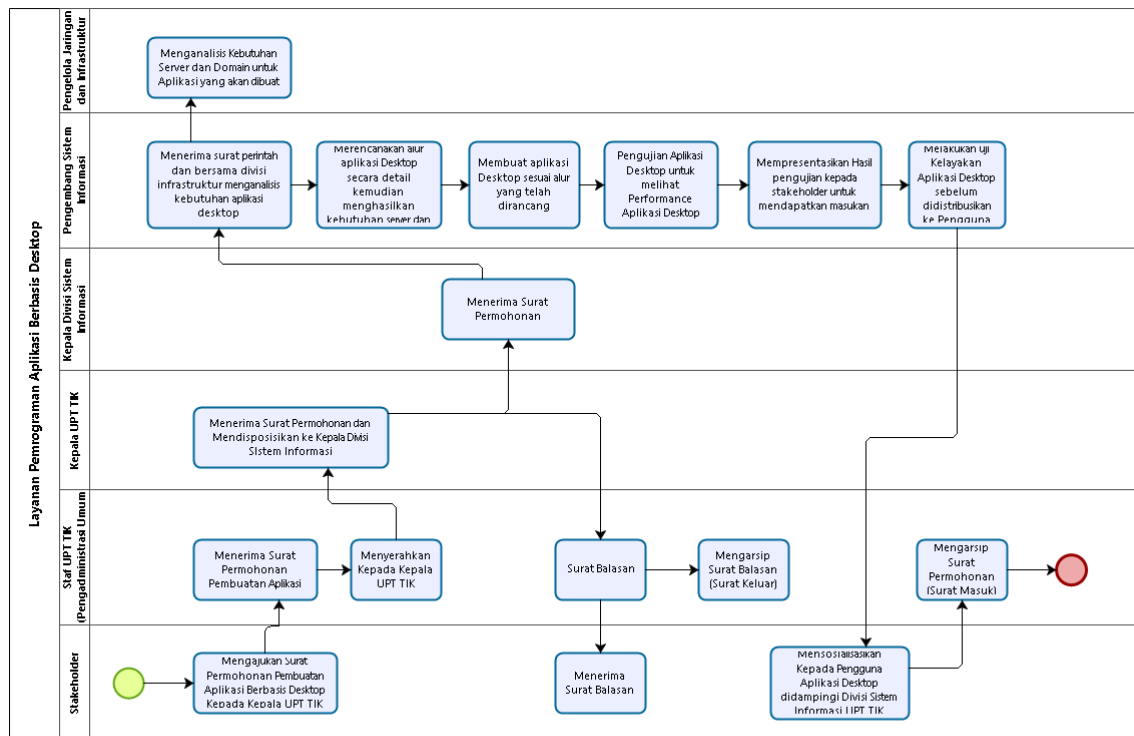

Level 3 Layanan Nilai Bermasalah

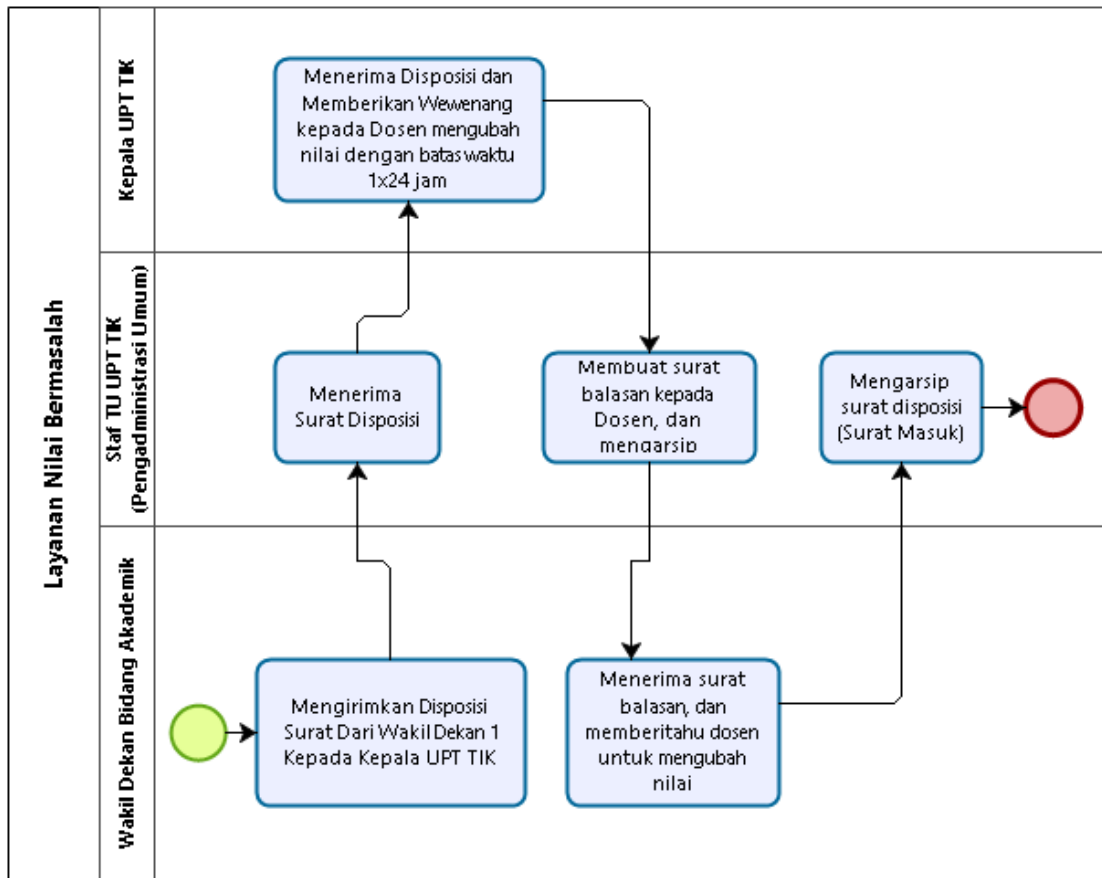

Level 2 Layanan Jaringan dan Infrastruktur

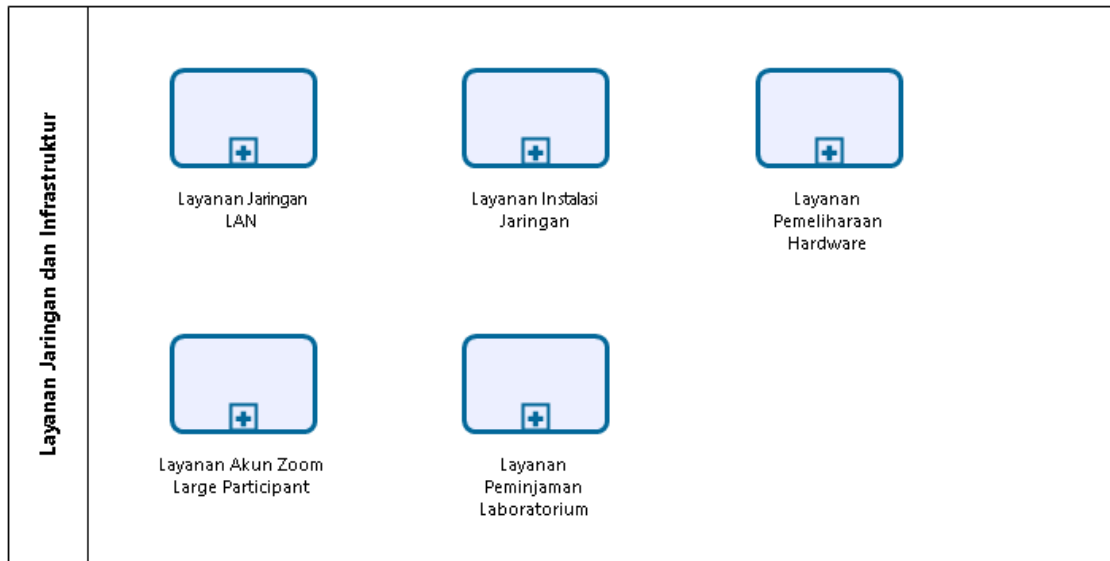

Powered by
bizagi
Modeler

Level 3 Layanan Jaringan LAN

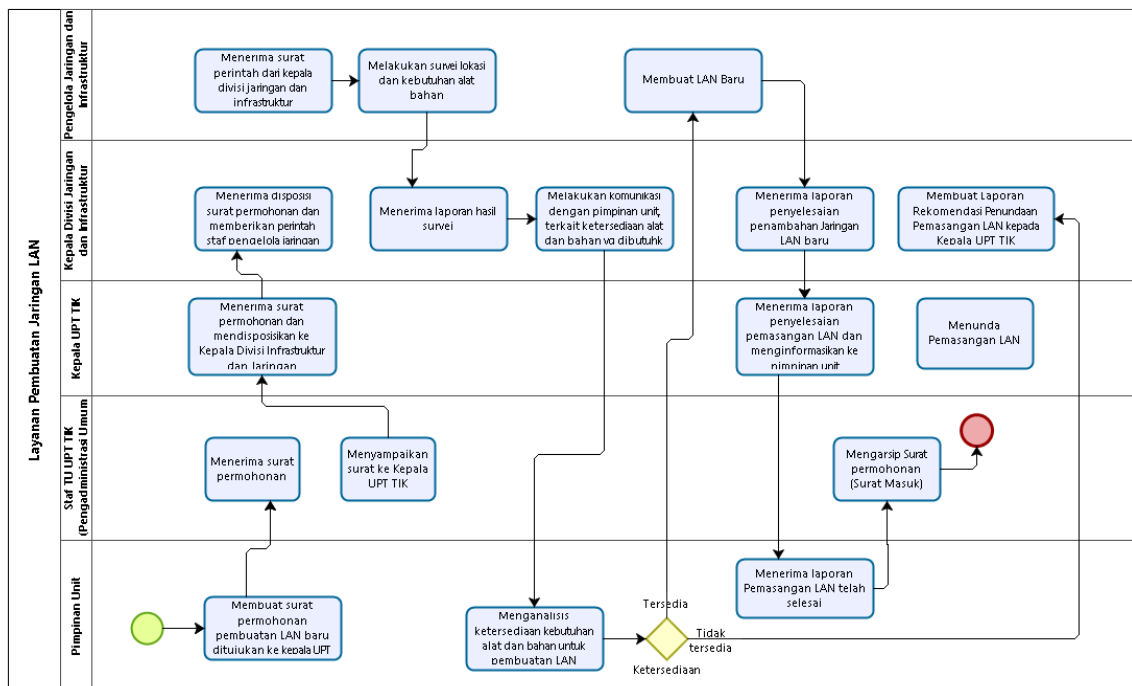

Powered by
bizagi
Modeler

Level 3 Layanan Instalasi Jaringan

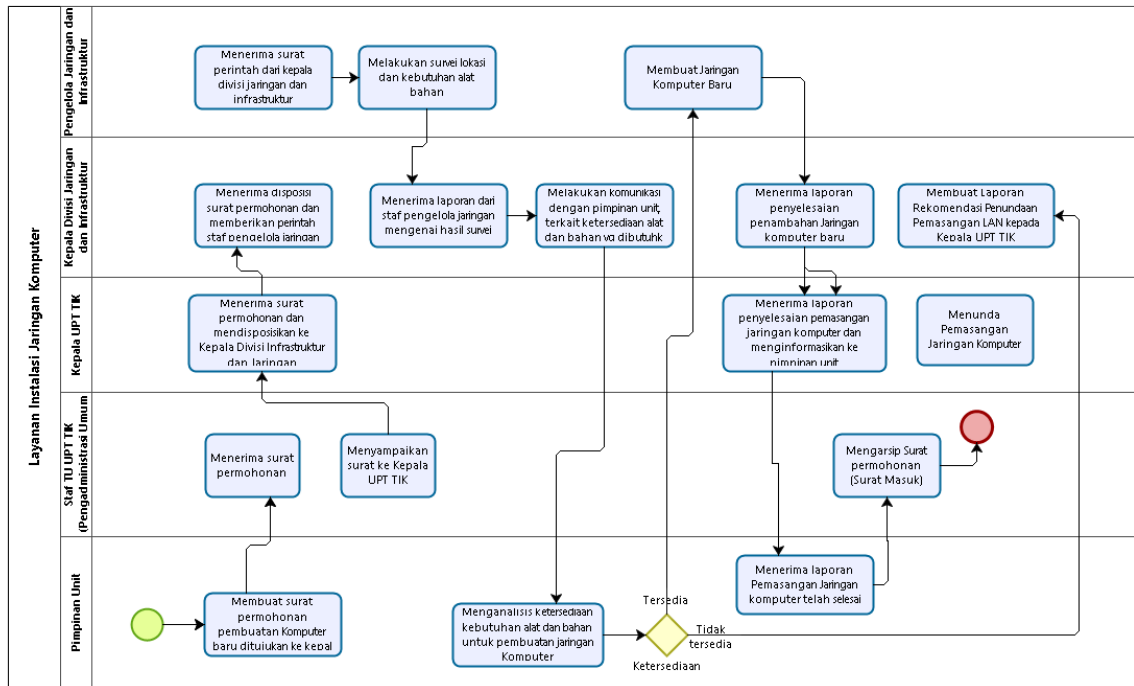

Powered by
bizagi
Modeler

Level 3 Layanan Pemeliharaan Hardware

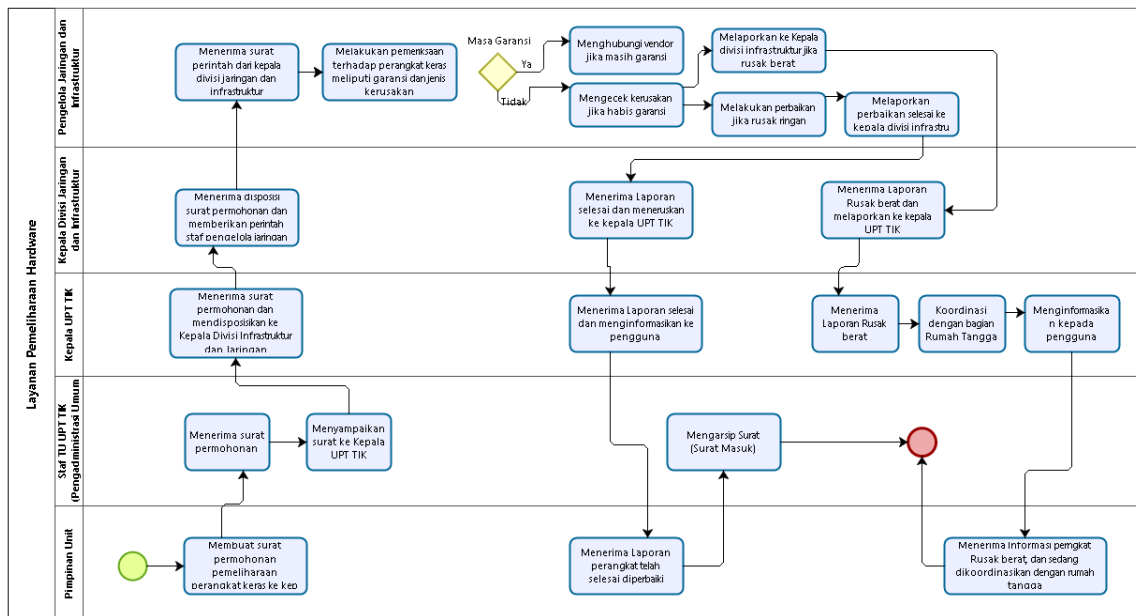

Powered by
bizagi
Modeler

Level 3 Layanan Akun Zoom Large Participant

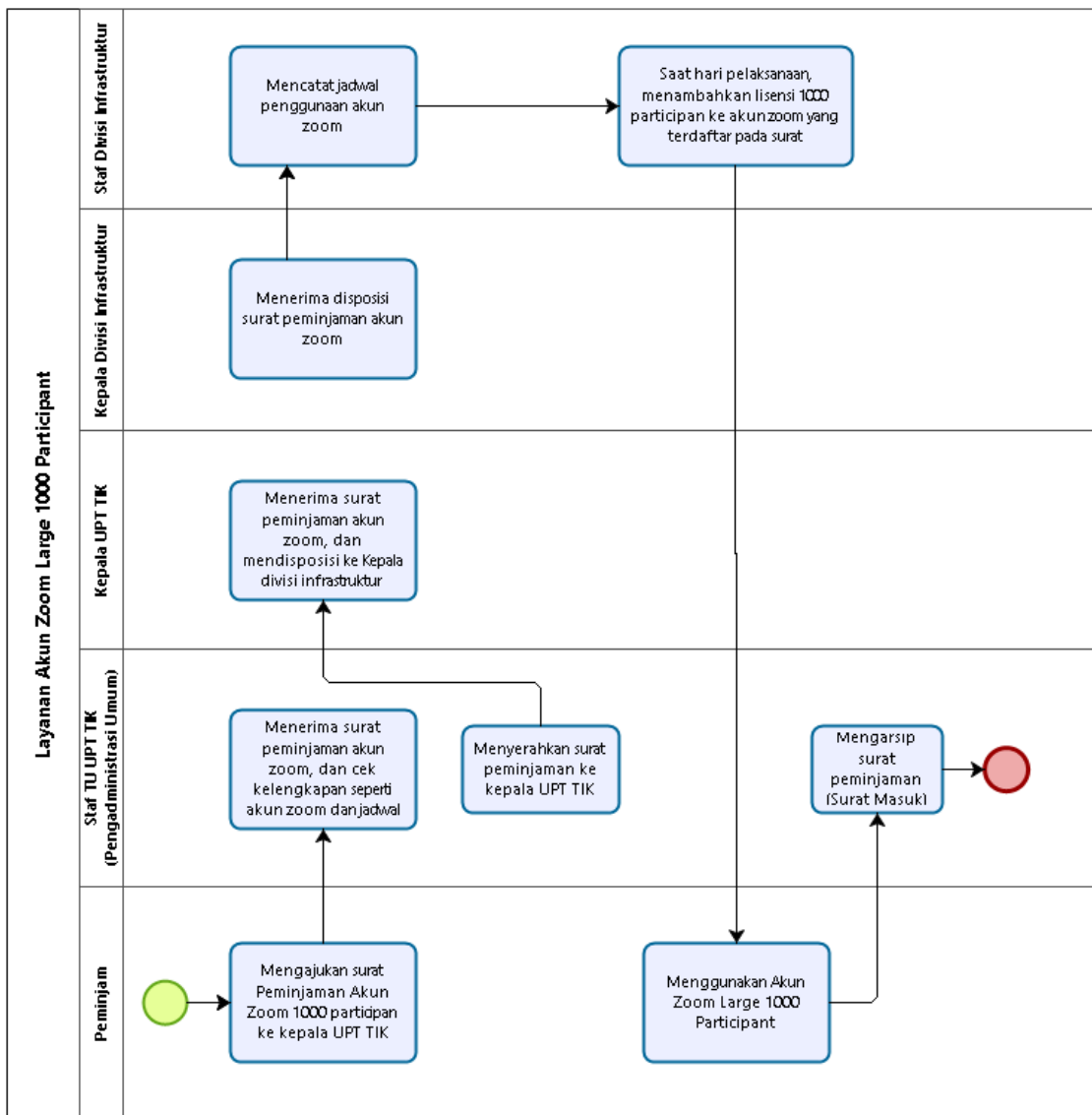

Level 3 Layanan Peminjaman Laboratorium

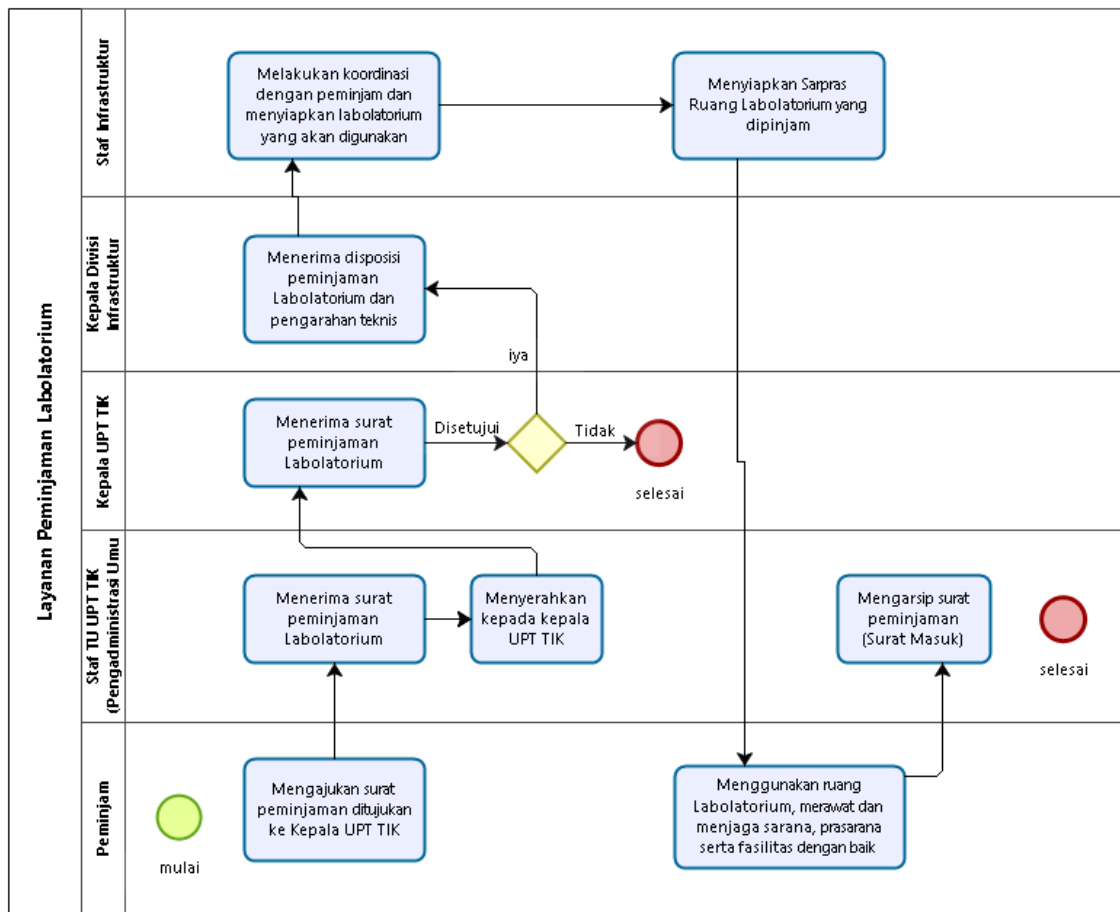

Level 2 Layanan Tata Usaha

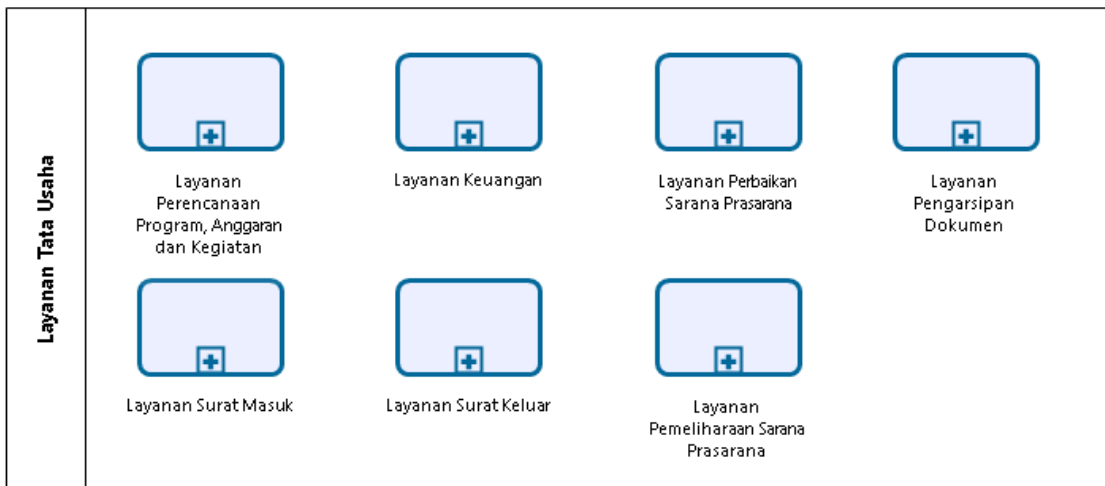

Powered by
bizagi
Modeler

Level 3 Layanan Perencanaan Program, Anggaran dan Kegiatan

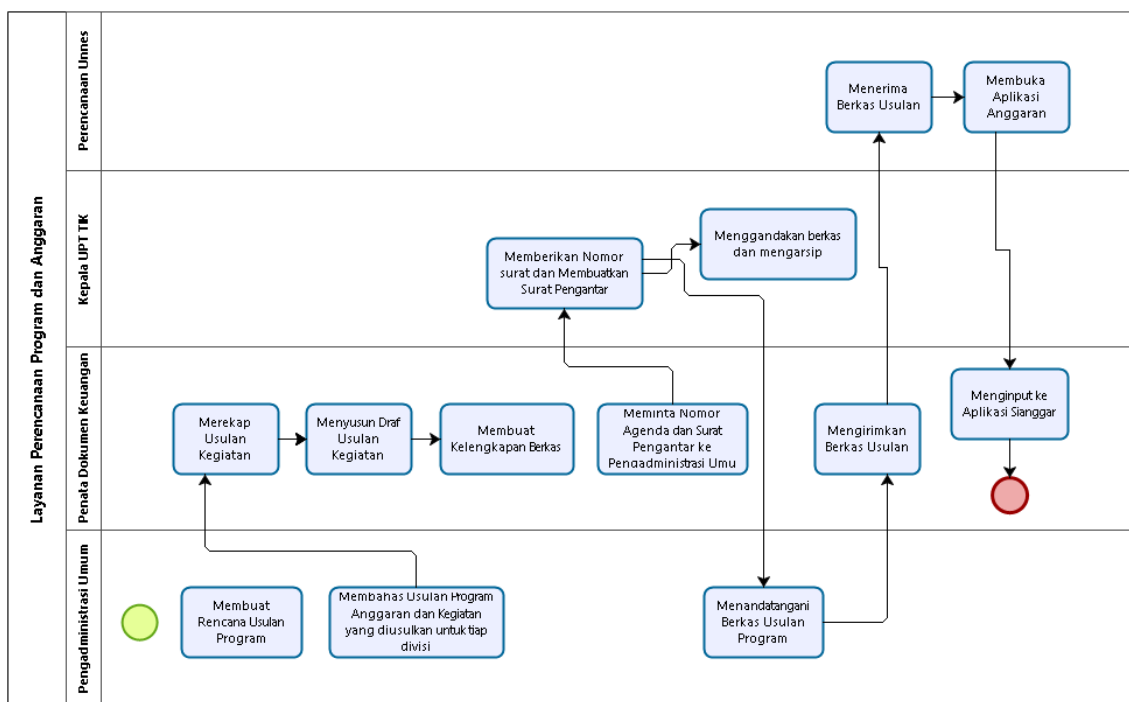

Powered by
bizagi
Modeler

Level 3 Layanan Keuangan

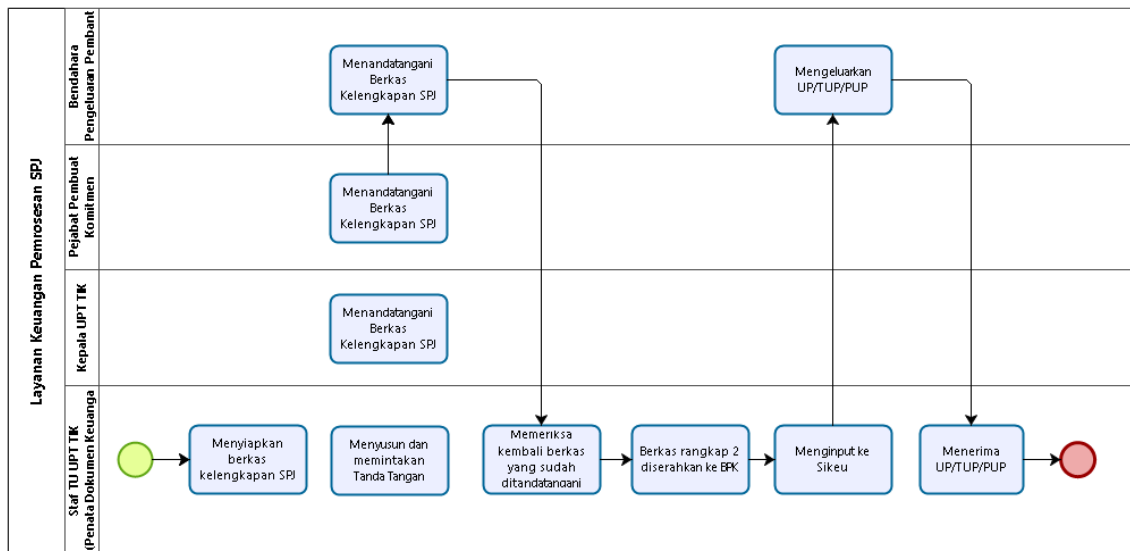

Level 3 Layanan Perbaikan Sarana Prasarana

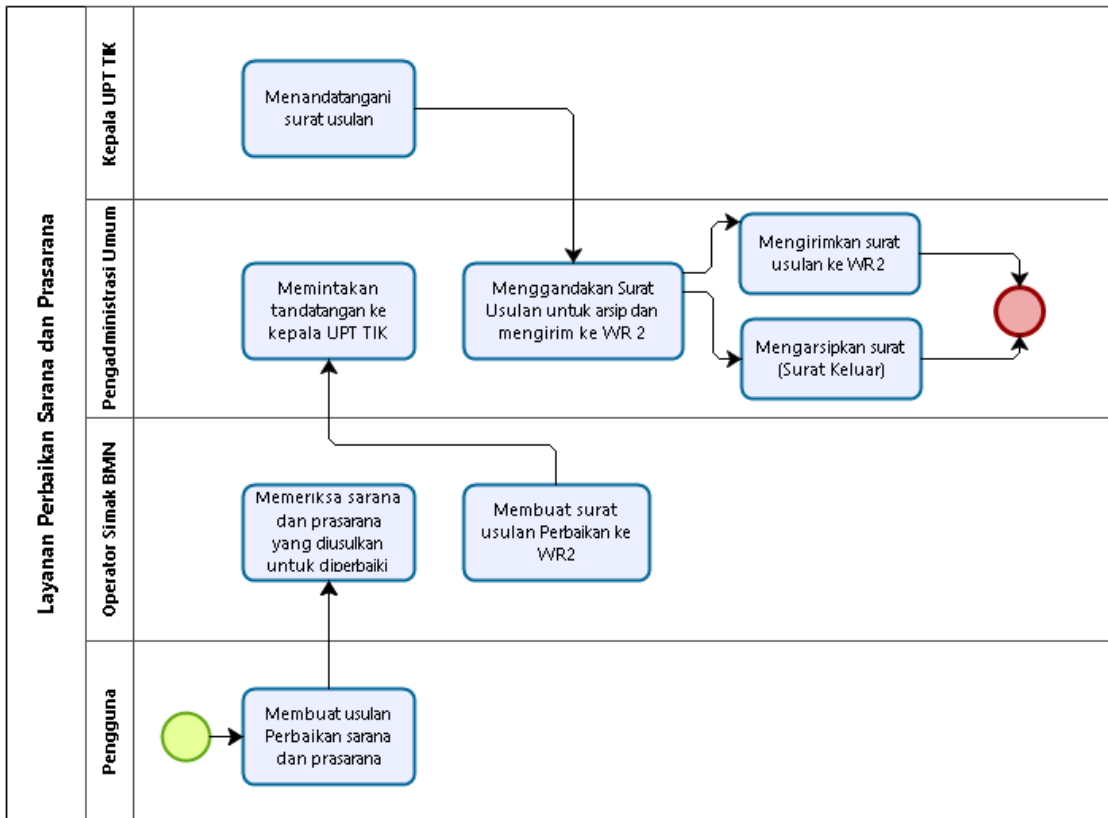

Powered by **bizagi** Modeler

Level 3 Layanan Pengarsipan Dokumen

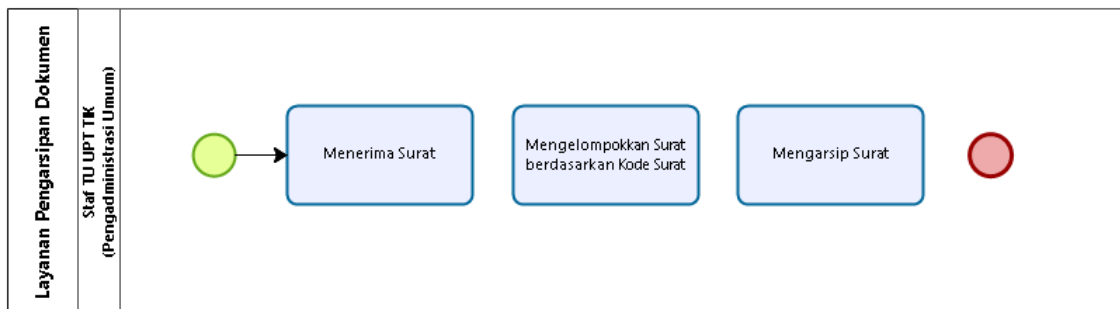

Powered by **bizagi** Modeler

Level 3 Layanan Surat Masuk

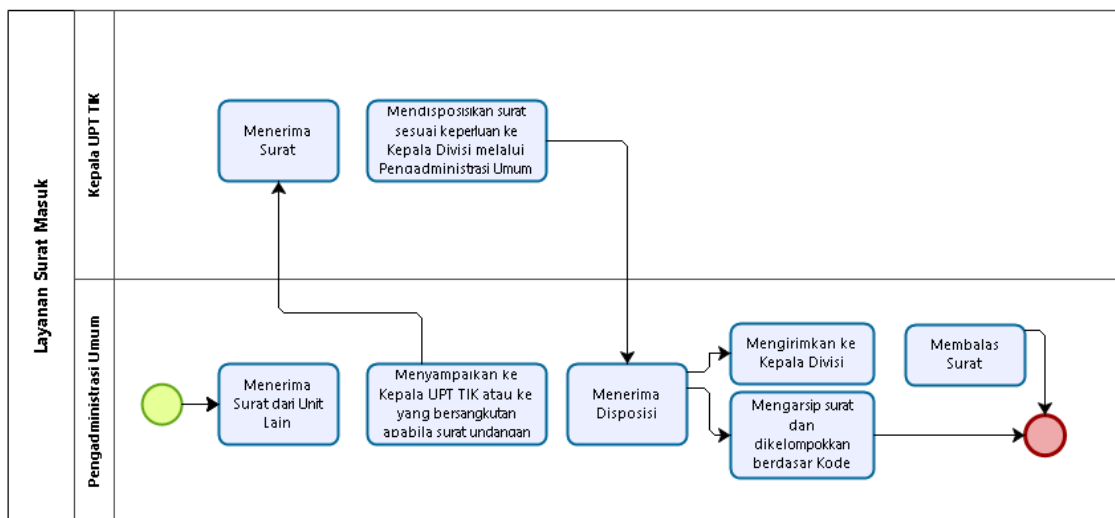

Powered by
bizagi
Modeler

Level 3 Layanan Surat Keluar

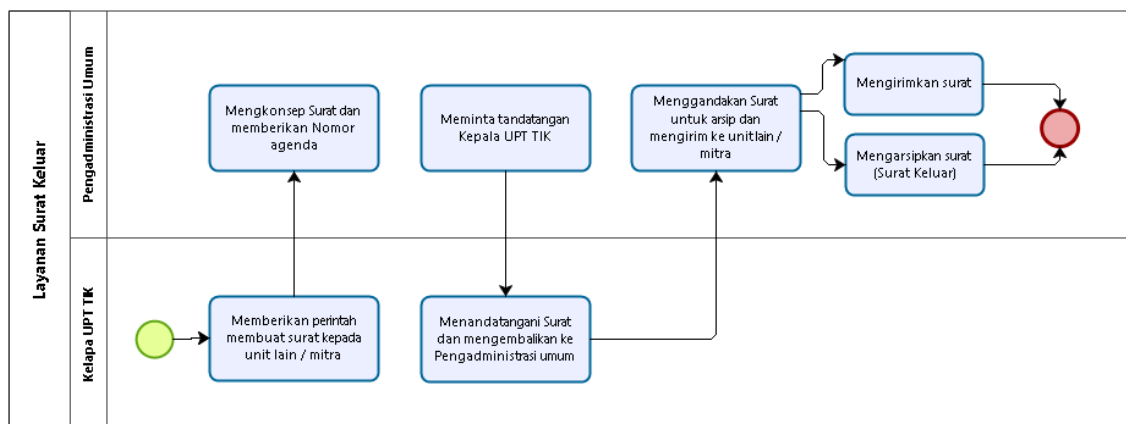

Powered by
bizagi
Modeler

Level 3 Layanan Pemeliharaan Sarana Prasarana

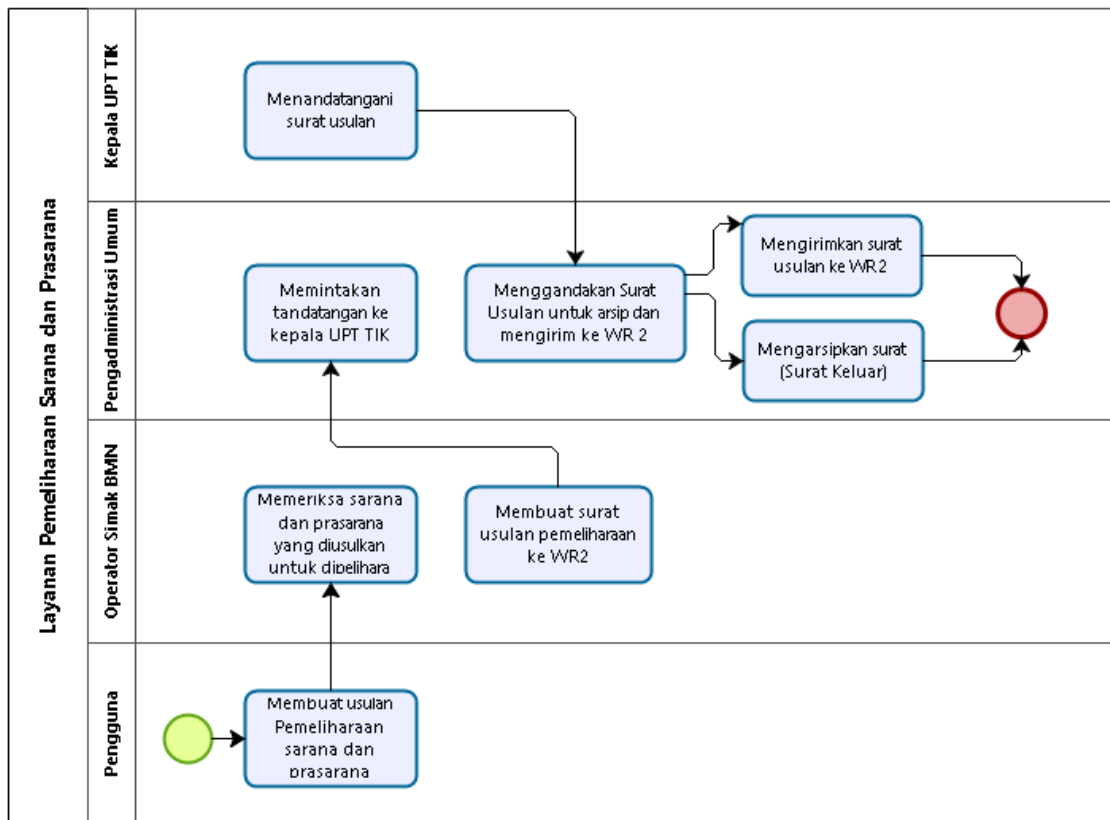

Level 2 Layanan Data

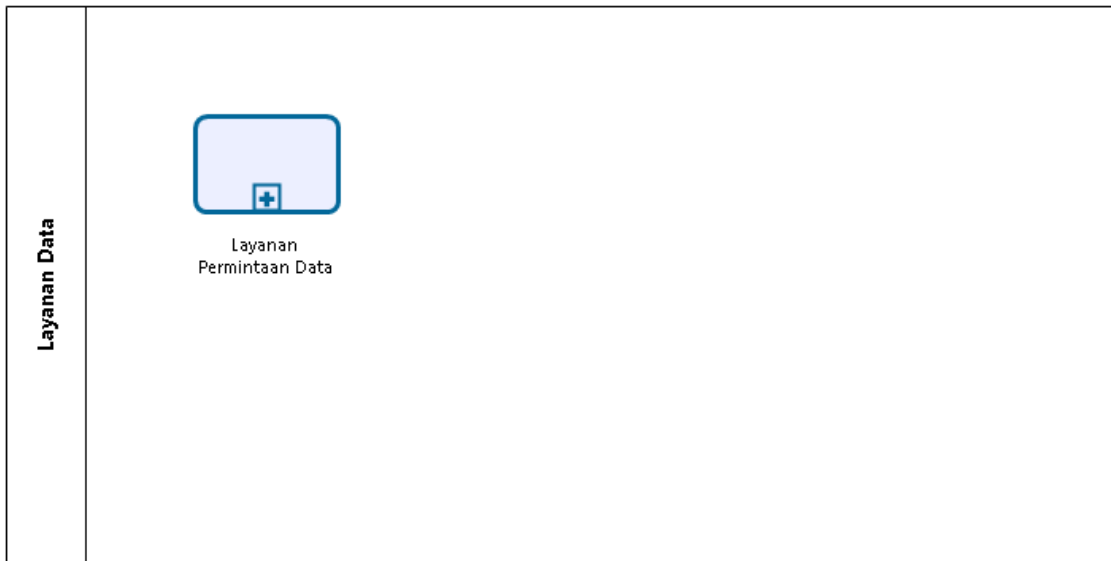

Powered by
bizagi
Modeler

Level 3 Layanan Permintaan Data

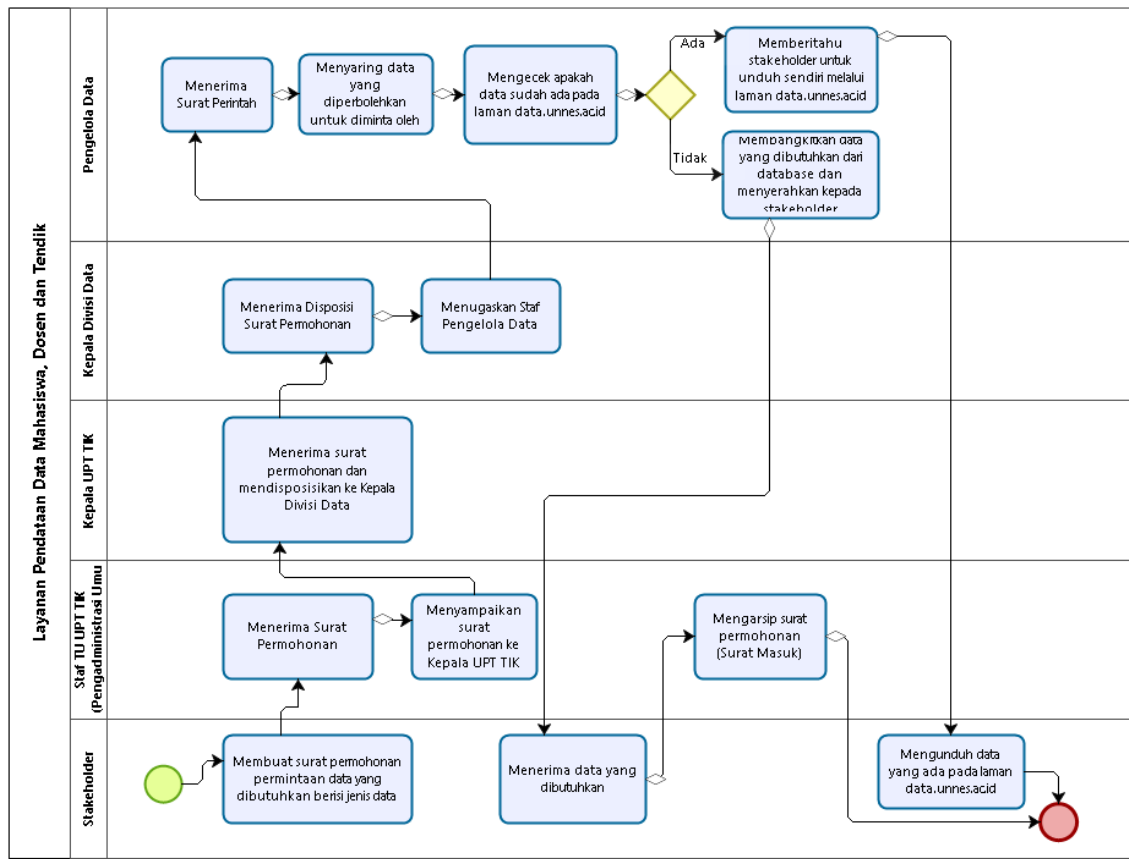

Level 2 Layanan Media

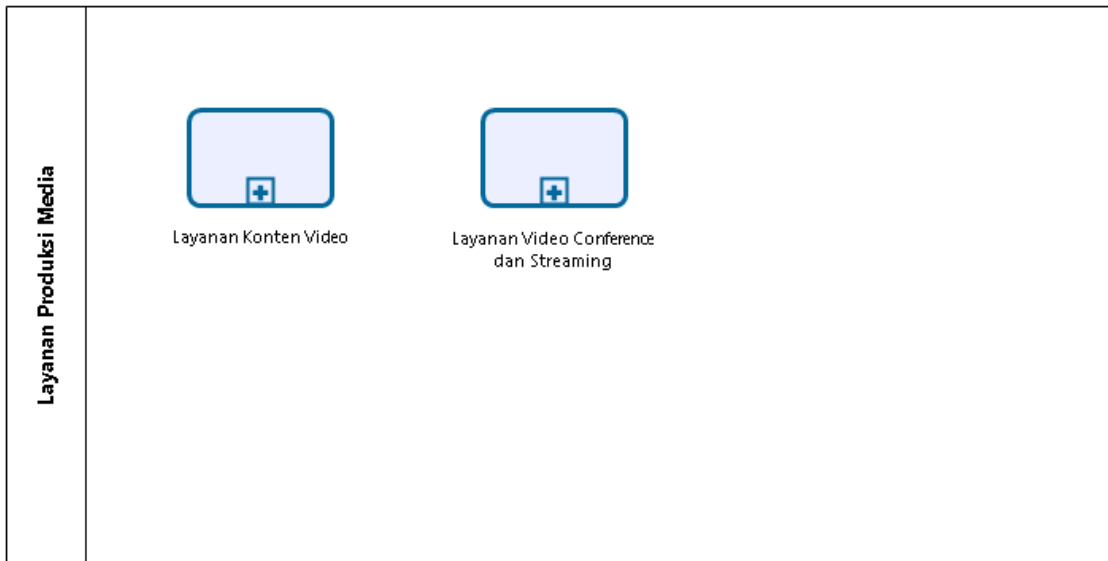

Powered by
bizagi
Modeler

Level 3 Layanan Konten Video

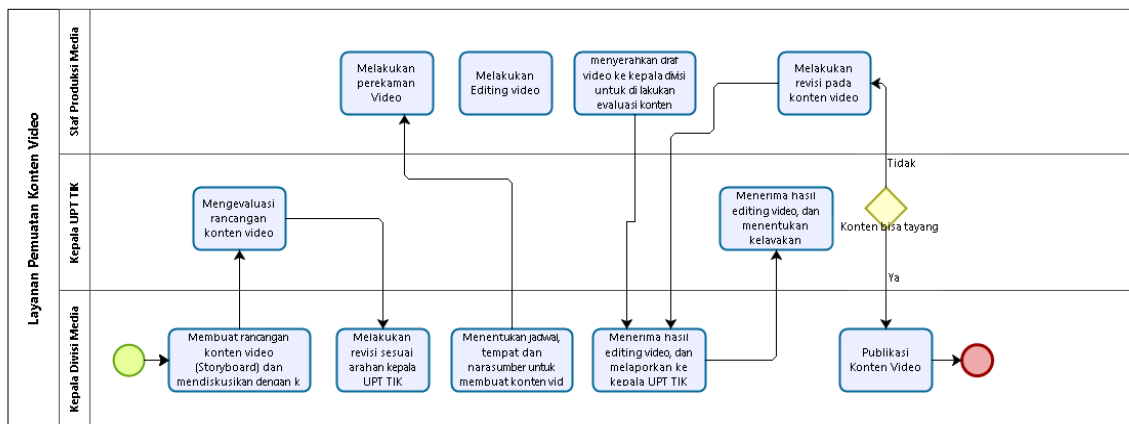

Powered by
bizagi
Modeler

Level 3 Layanan Video Conference dan Streaming

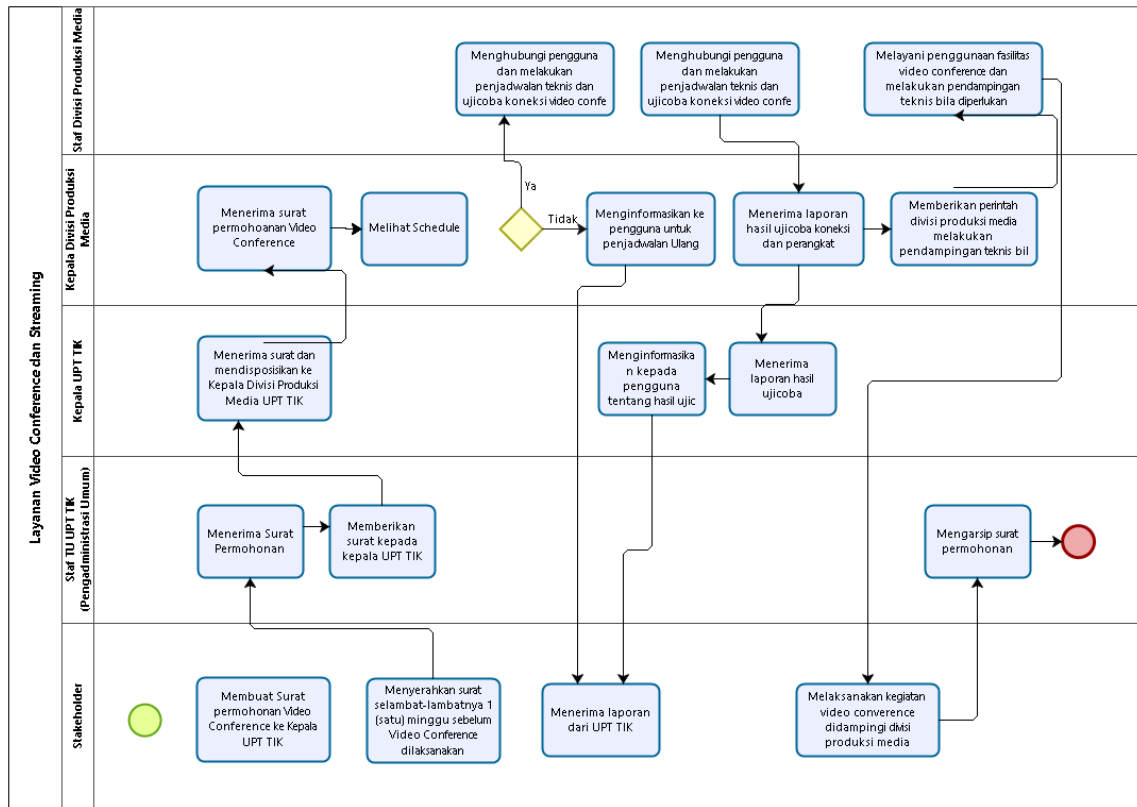

Level 2 Layanan Digital Smart Campus



Powered by
bizagi
Modeler

Level 3 Layanan Pelatihan Digital Smart Campus

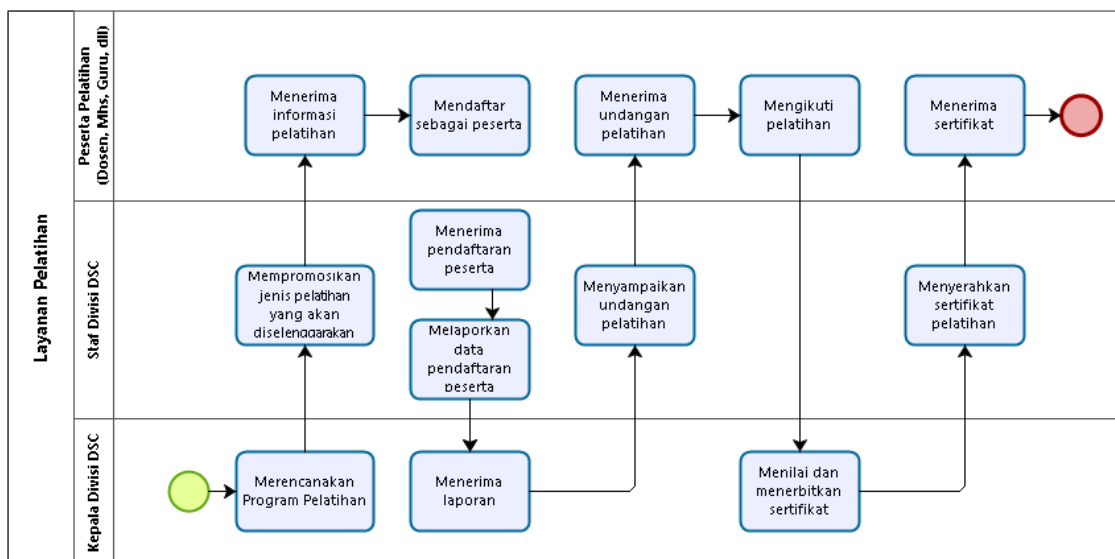

Powered by
bizagi
Modeler

Level 1 Layanan Pengembangan Konservasi

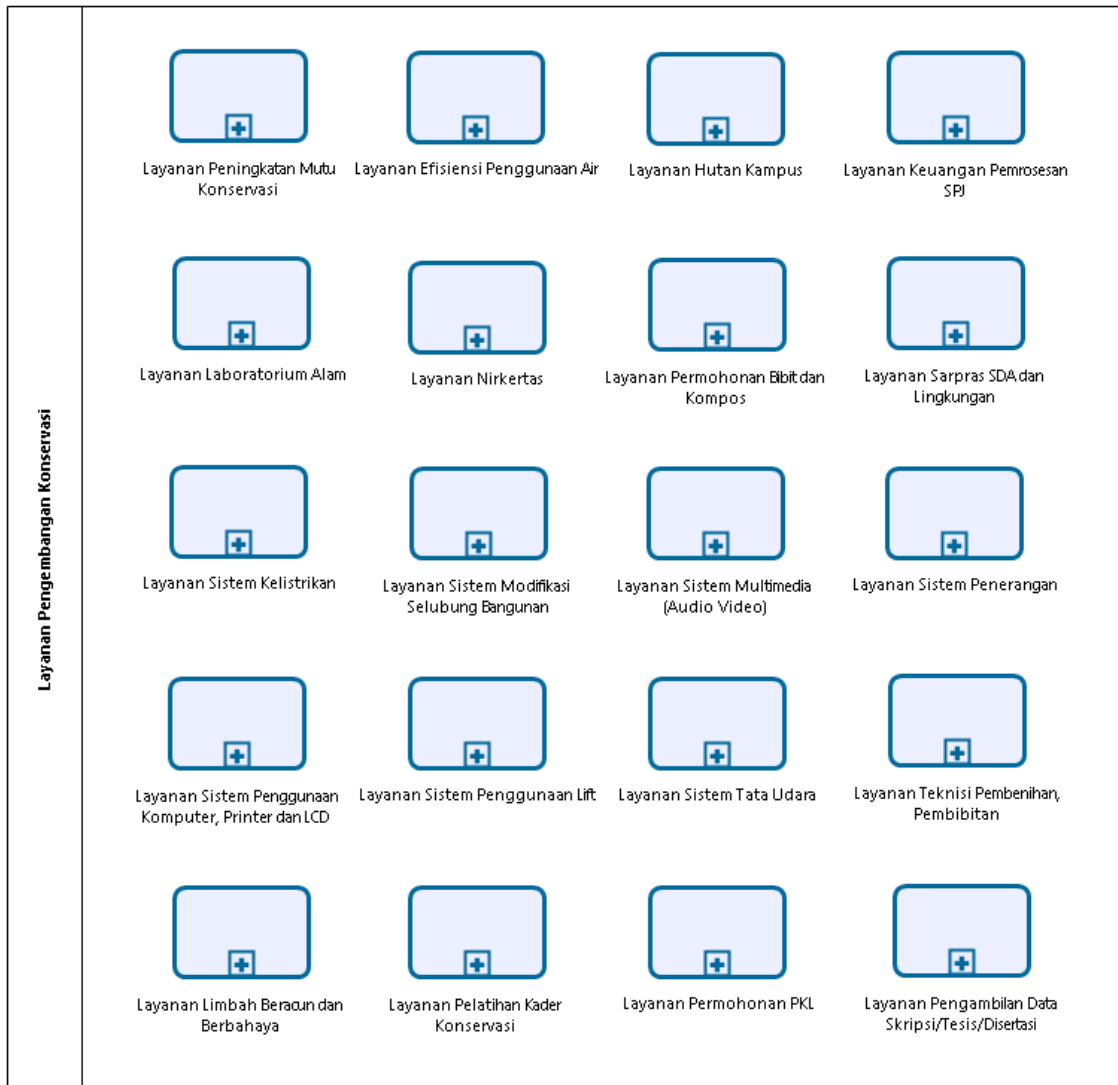

Level 2 Layanan Peningkatan Mutu Konservasi

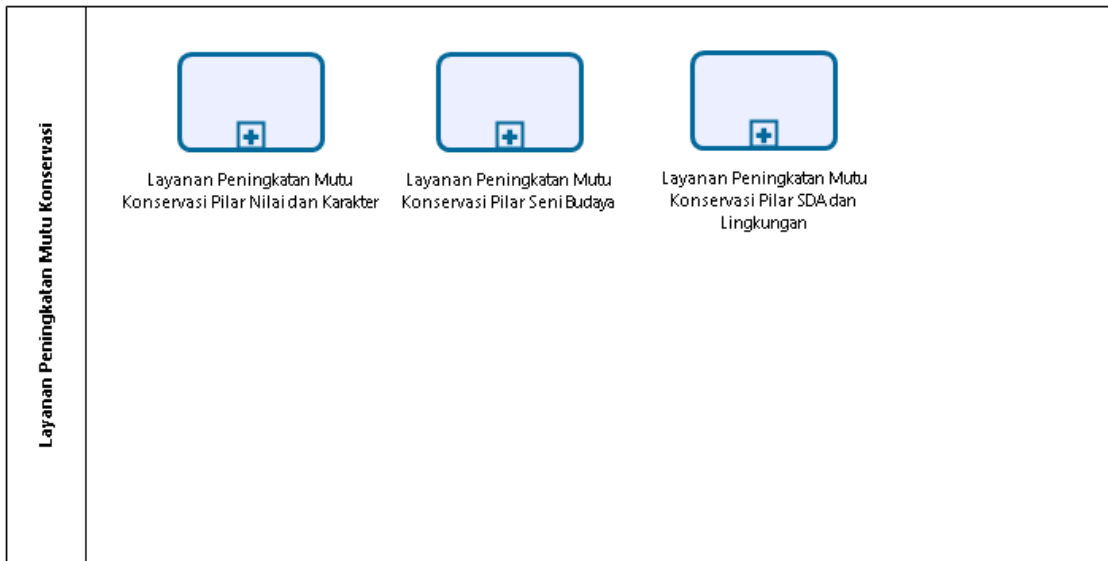

Powered by
bizagi
Modeler

Level 3 Layanan Peningkatan Mutu Konservasi Pilar Nilai dan Karakter

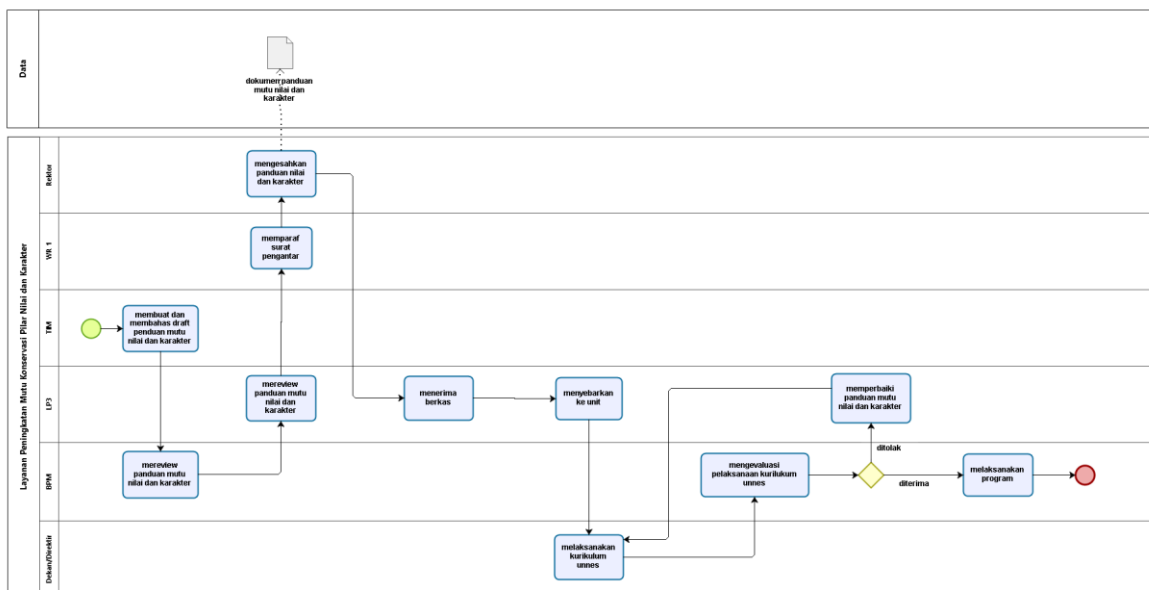

Powered by
bizagi
Modeler

Level 3 Layanan Peningkatan Mutu Konservasi Nilai Seni Budaya

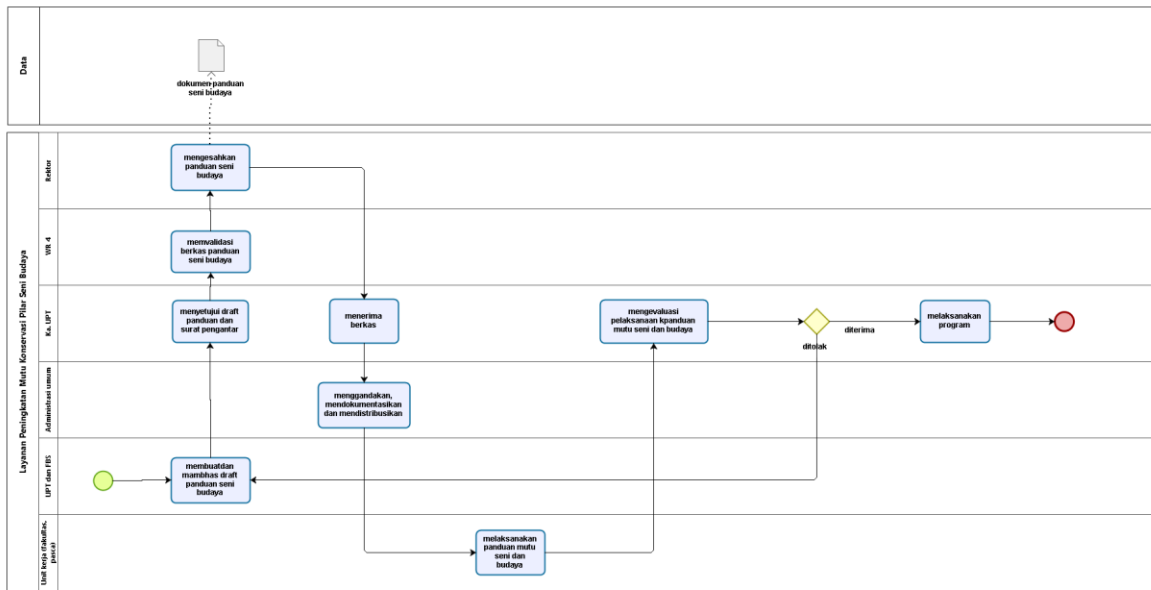

Level 3 Layanan Peningkatan Mutu Konservasi Pilar SDA dan Lingkungan

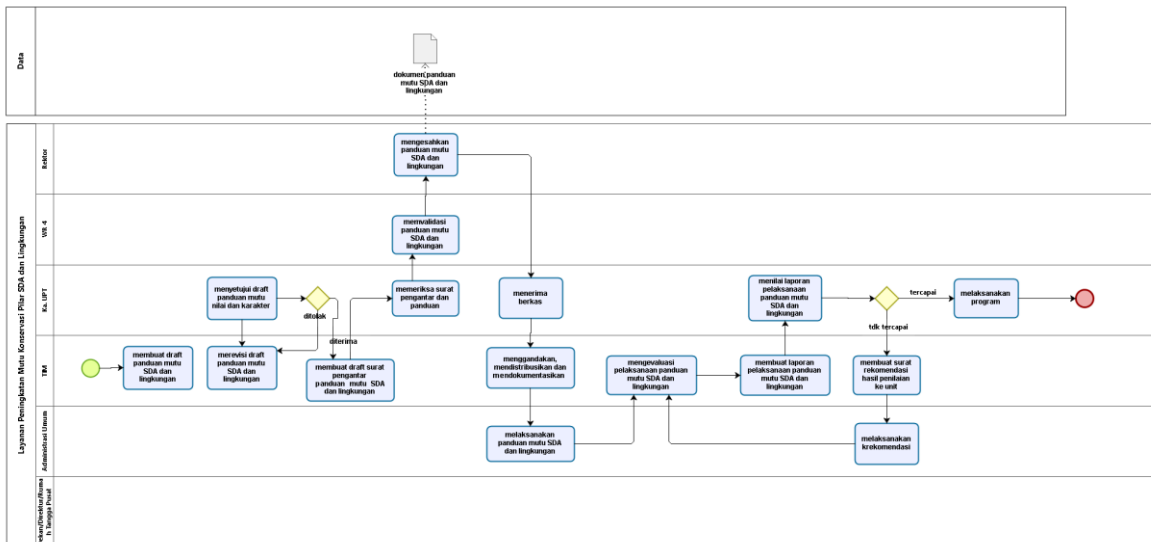

Level 2 Layanan Efisiensi Penggunaan Air

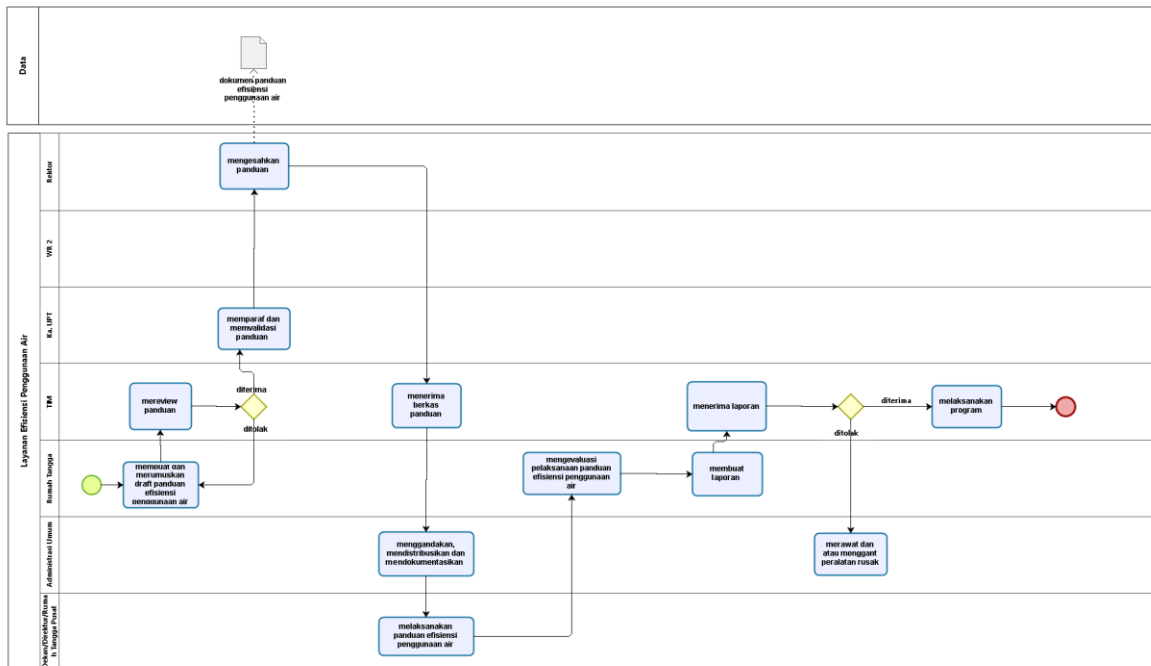

Level 2 Layanan Hutan Kampus

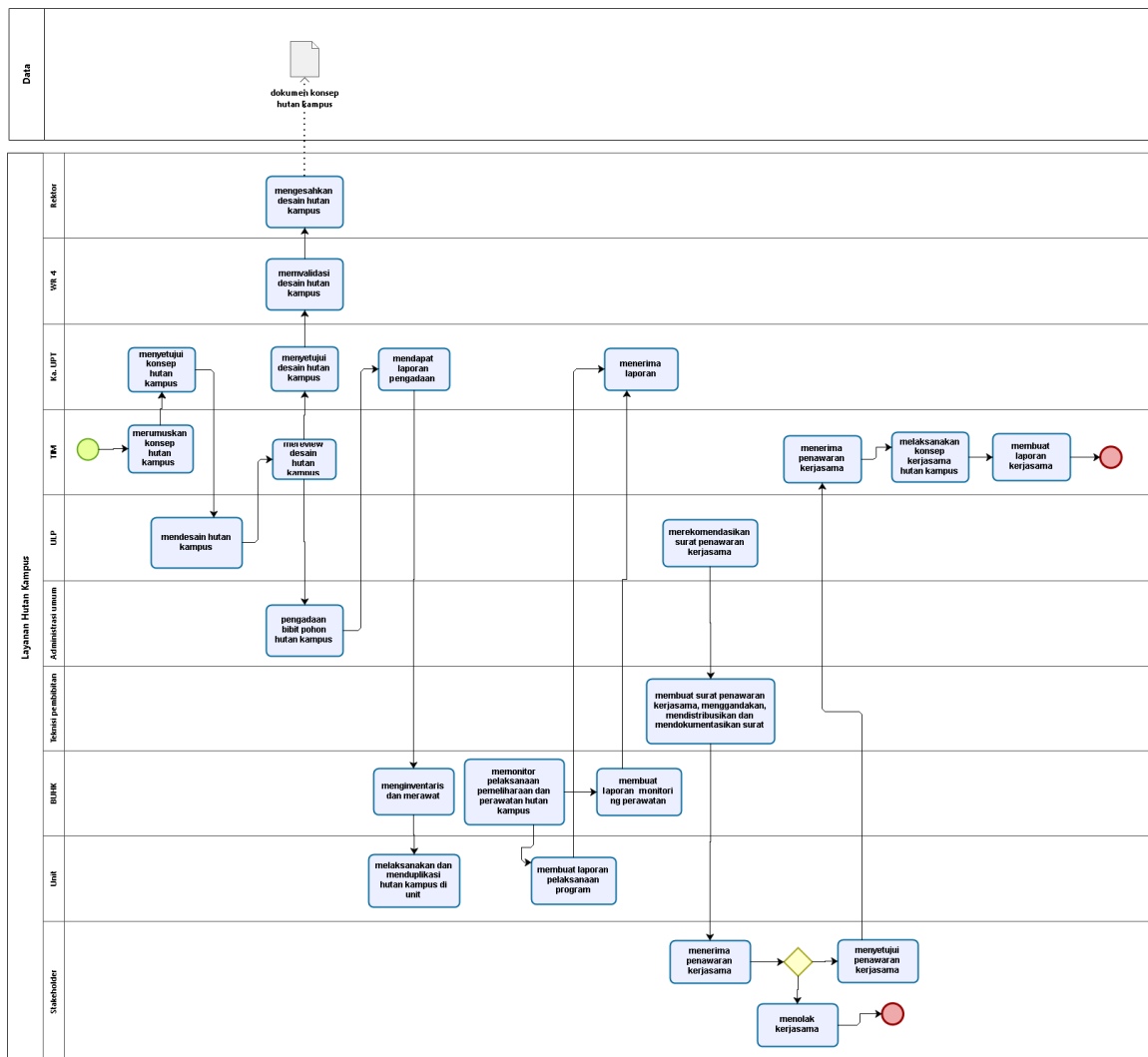

Level 2 Layanan Laboratorium Alam

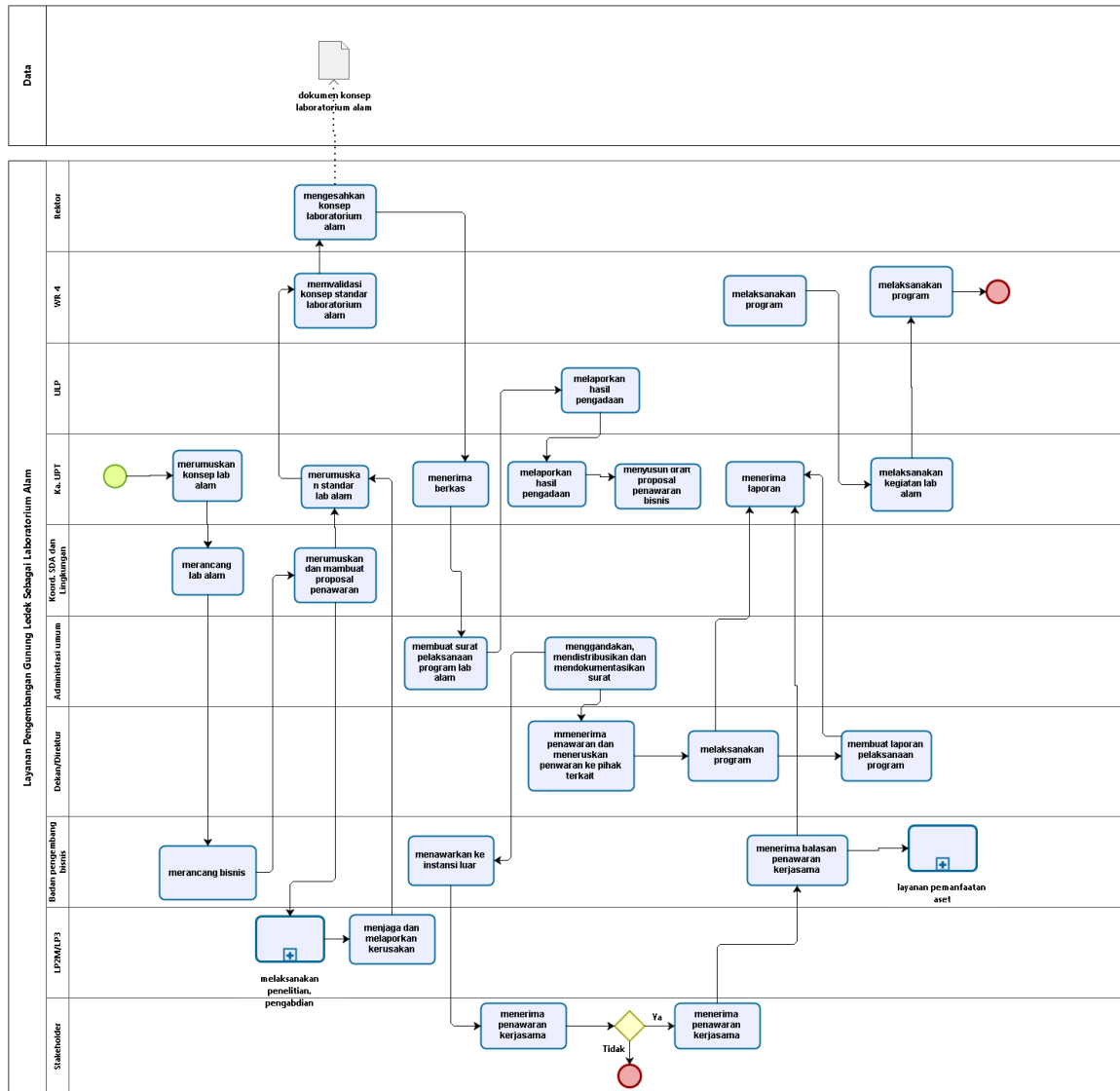

Level 2 Layanan Nirkertas

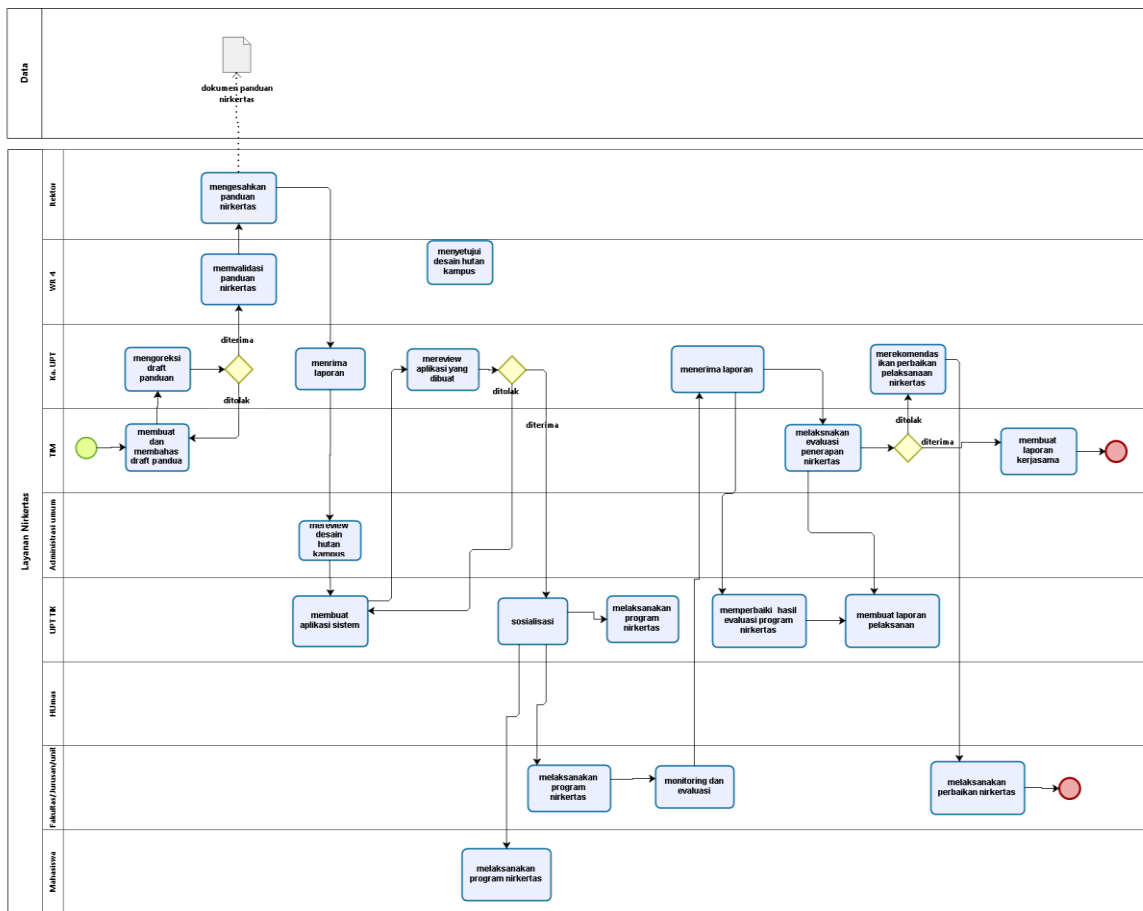

Level 2 Layanan Permohonan Bibit dan Kompos

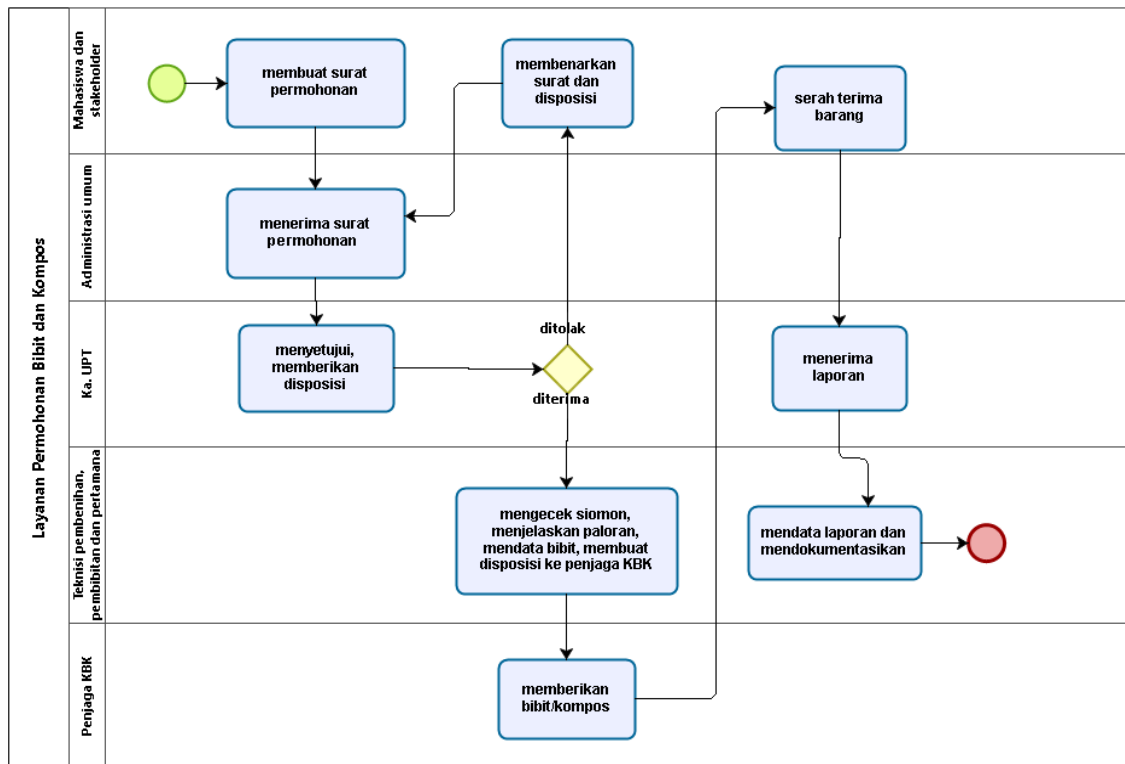

Level 2 Layanan Sarpras SDA dan Lingkungan

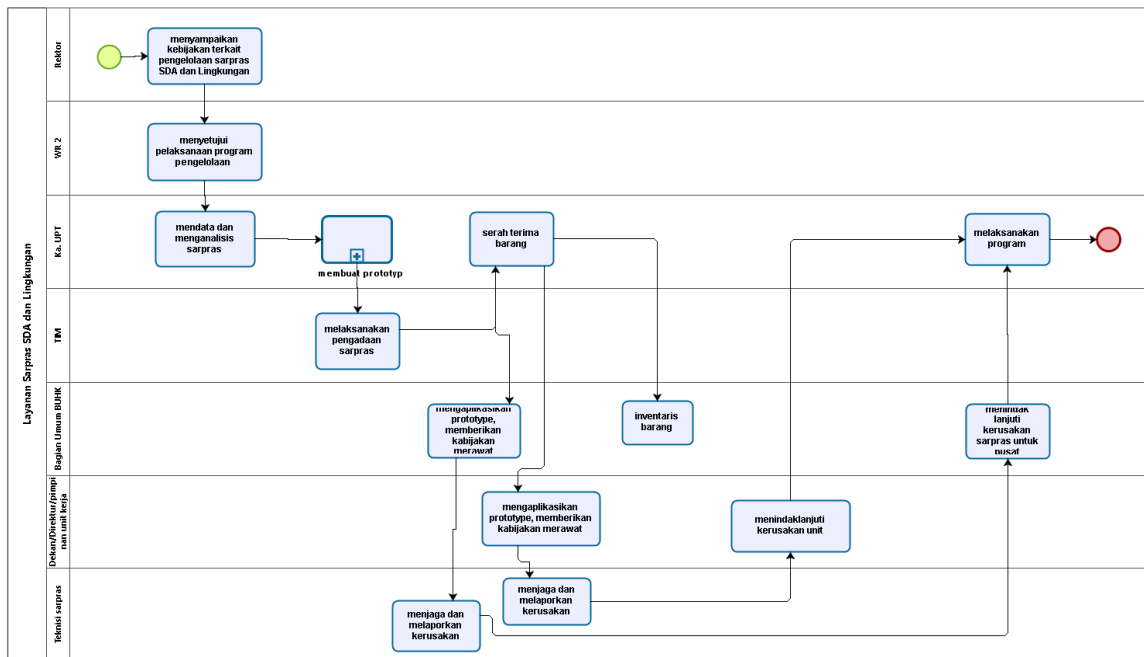

Powered by
bizagi
Model

Level 2 Layanan Sistem Kelistrikan

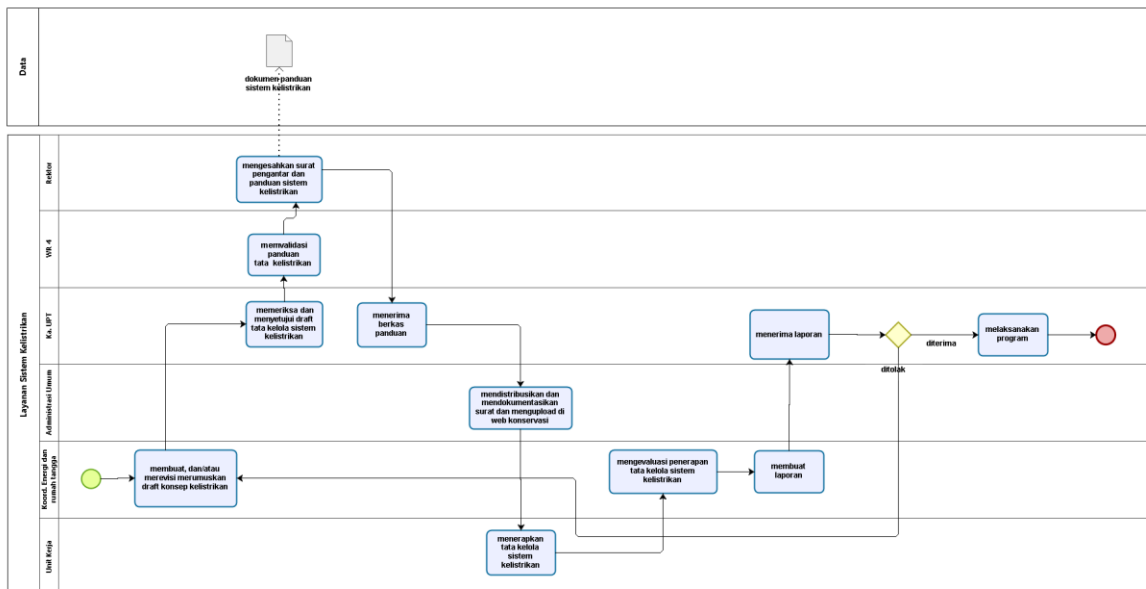

Powered by
bizagi
Model

Level 2 Layanan Sistem Modifikasi Selubung Bangunan

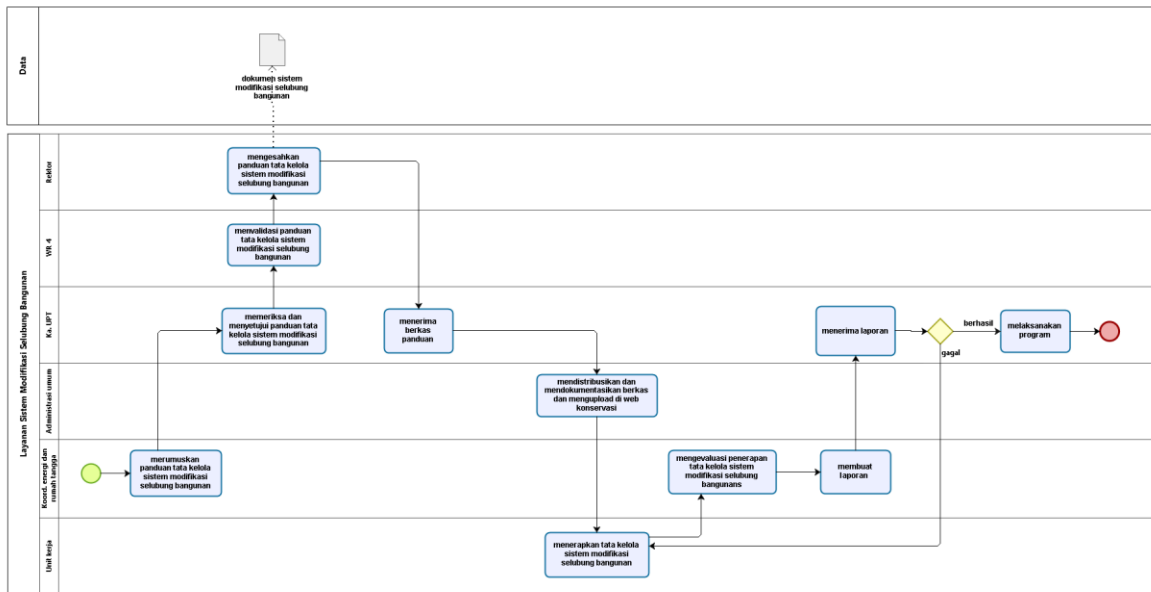

Powered by
bizagi
Workflow

Level 2 Layanan Sistem Multimedia (Audio Video)

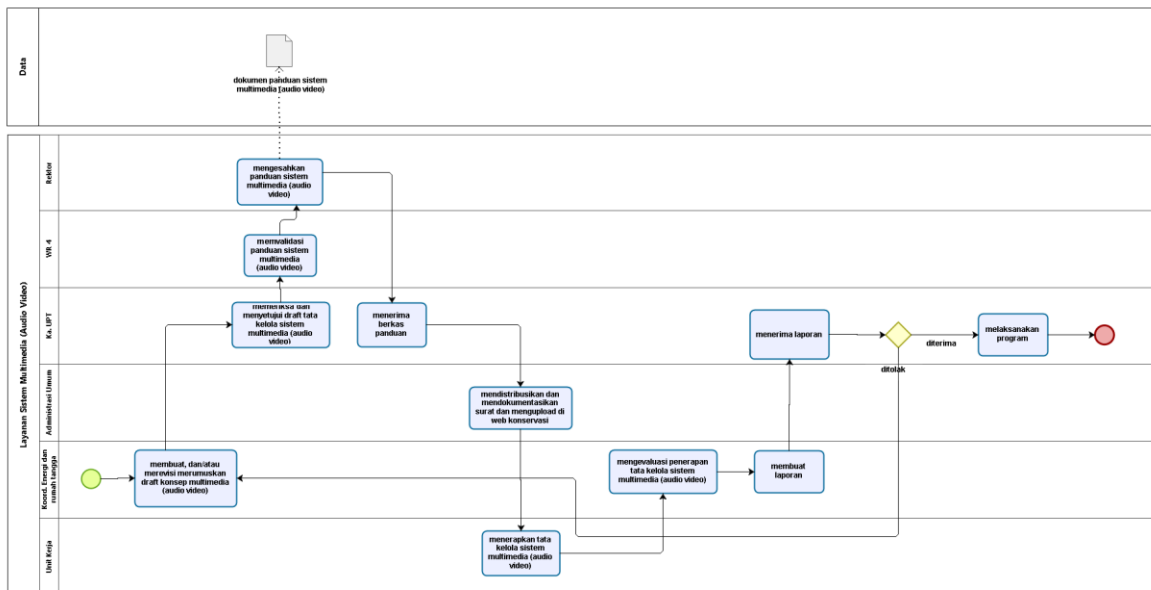

Powered by
bizagi
Workflow

Level 2 Layanan Sistem Penerangan

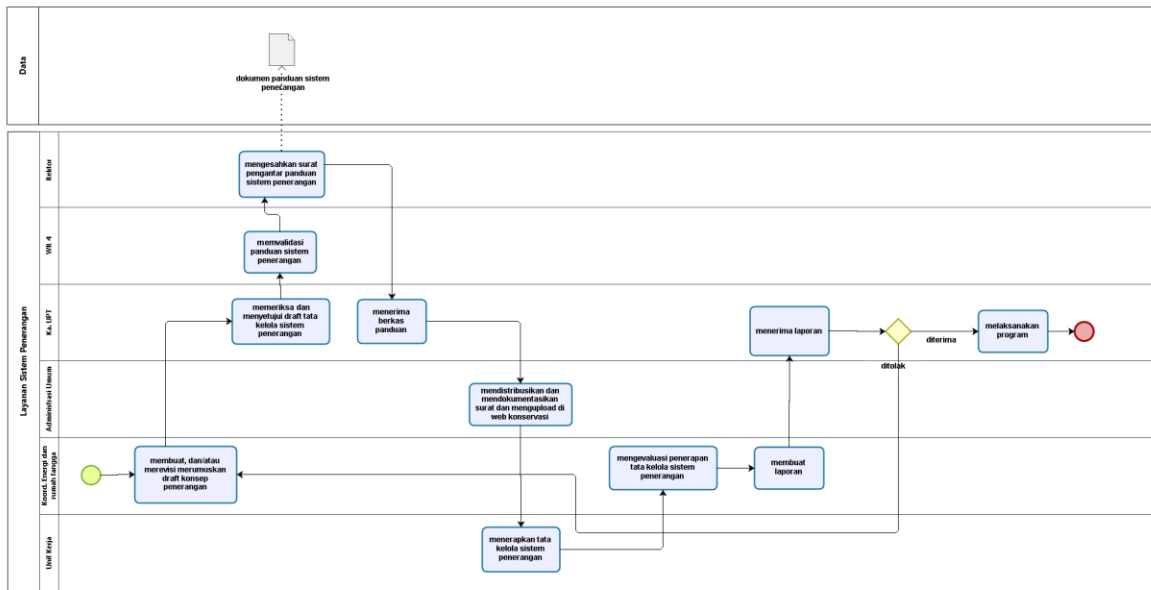

Powered by bizagi

Level 2 Layanan Sistem Penggunaan Komputer, Printer dan LCD

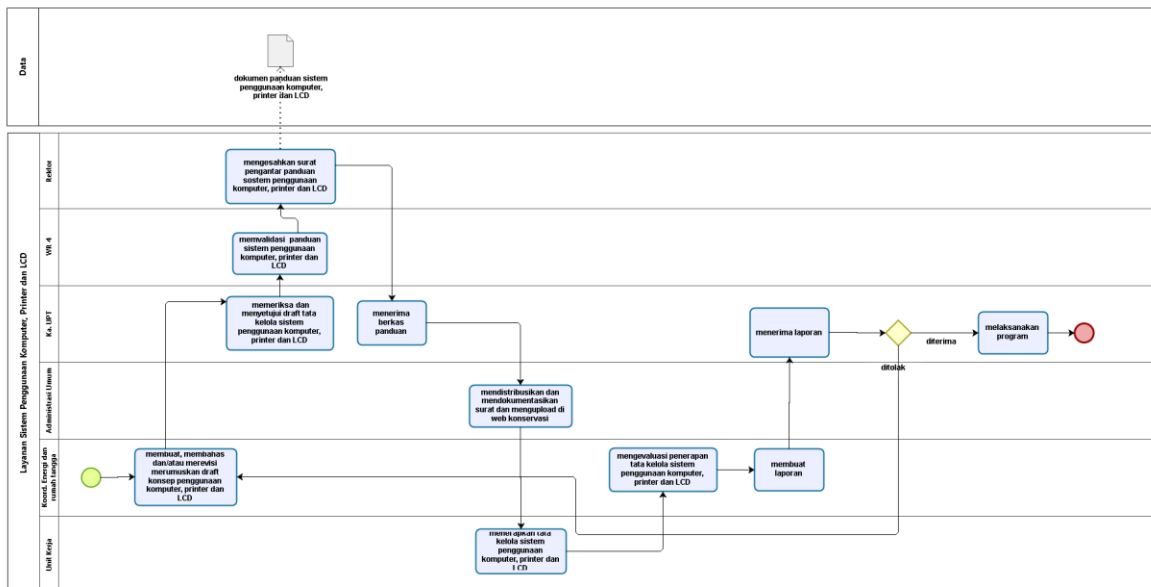

Powered by bizagi

Level 2 Layanan Sistem Penggunaan Lift

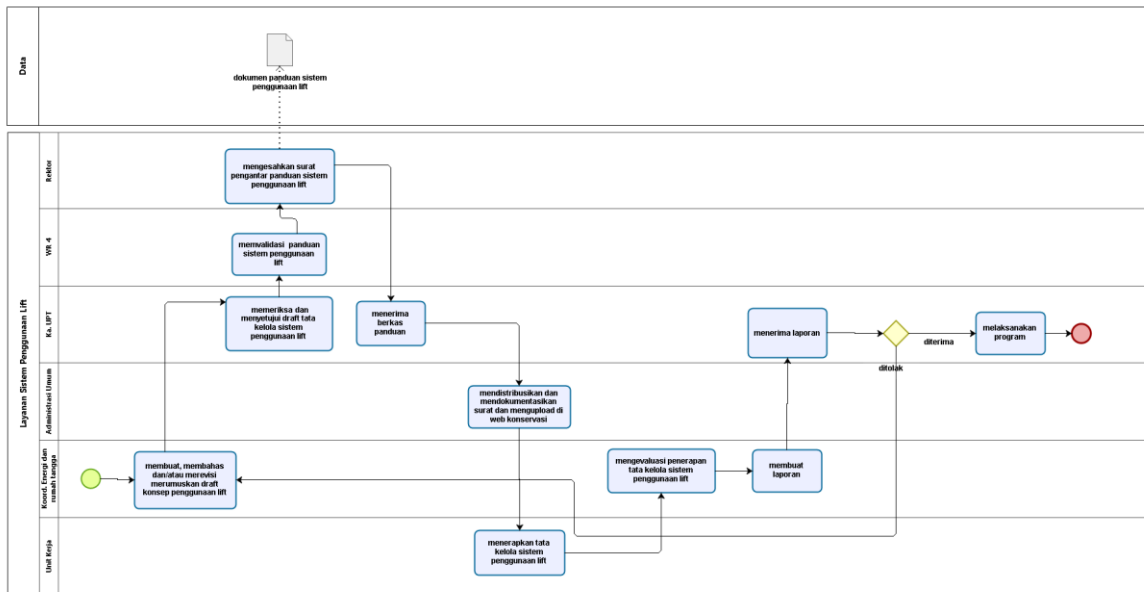

Powered by bizagi

Level 2 Layanan Sistem Tata Udara

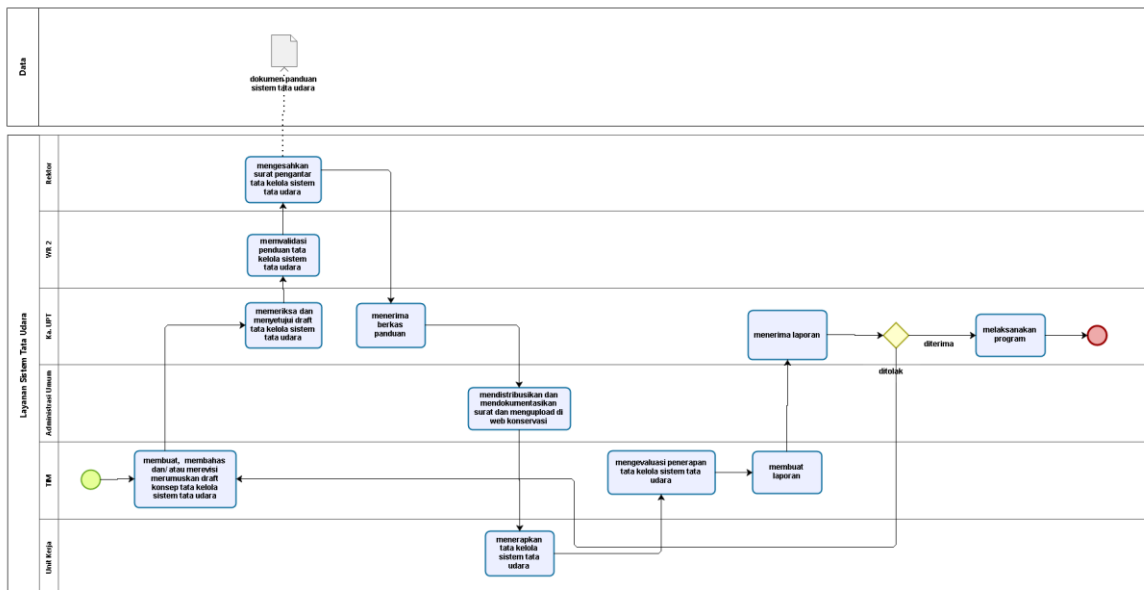

Powered by bizagi

Level 2 Layanan Teknisi Pembenhian, Pembibitan

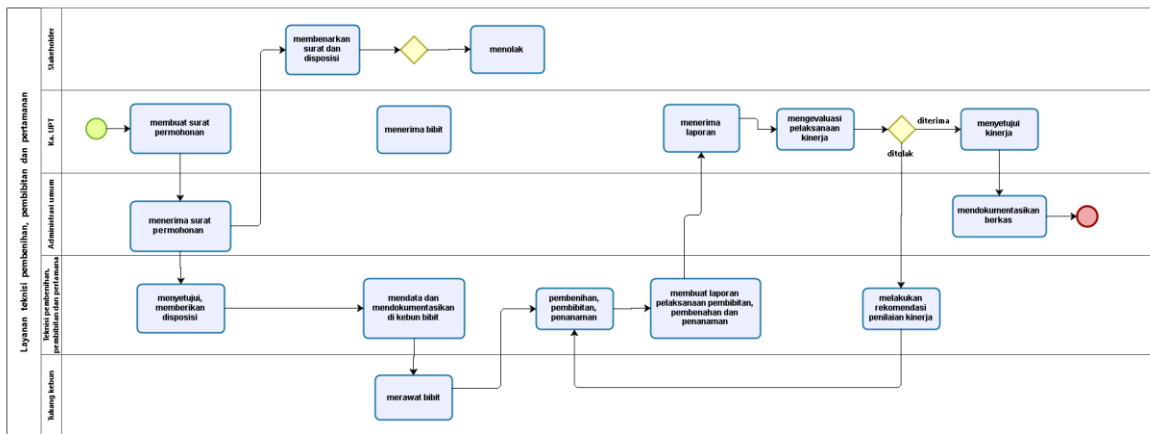

Level 2 Layanan Limbah Beracun dan Berbahaya

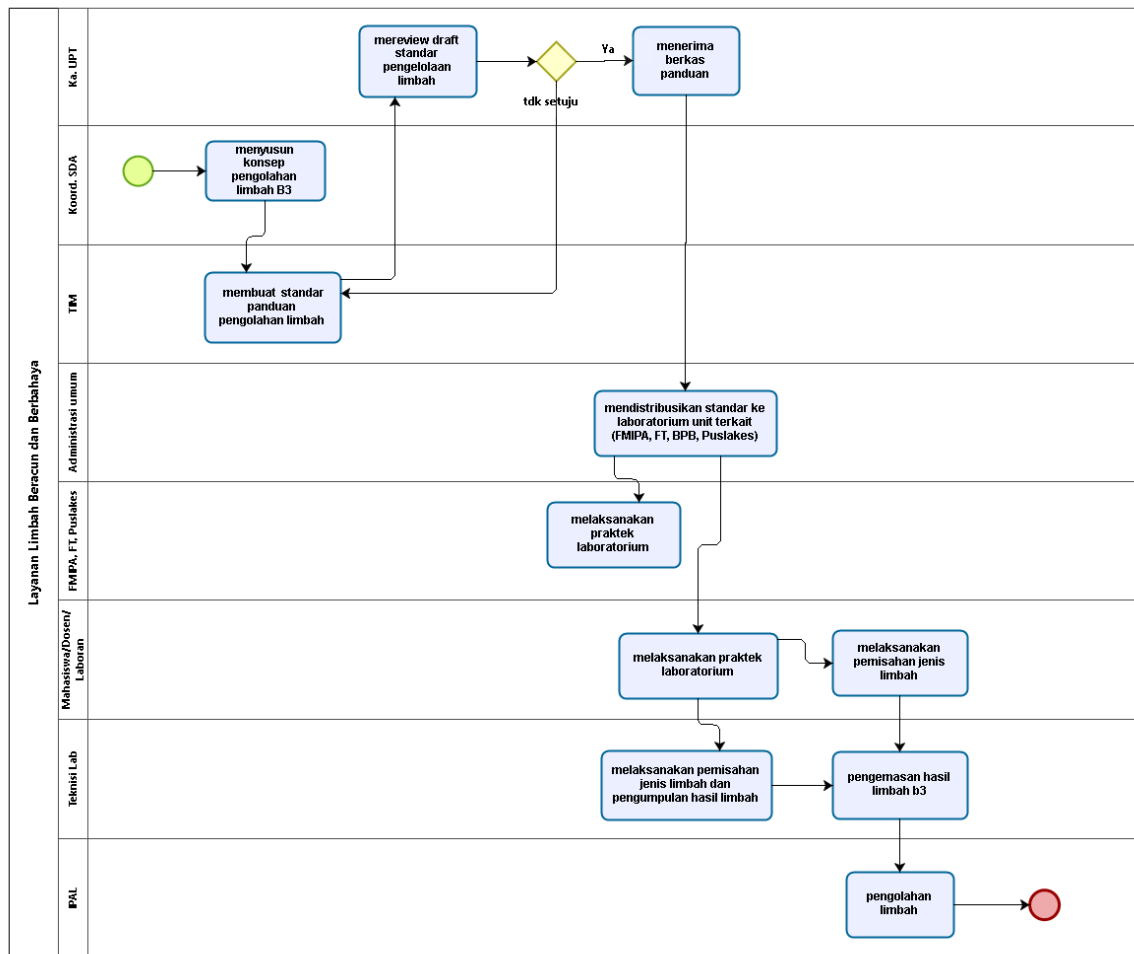

Level 2 Layanan Permohonan PKL

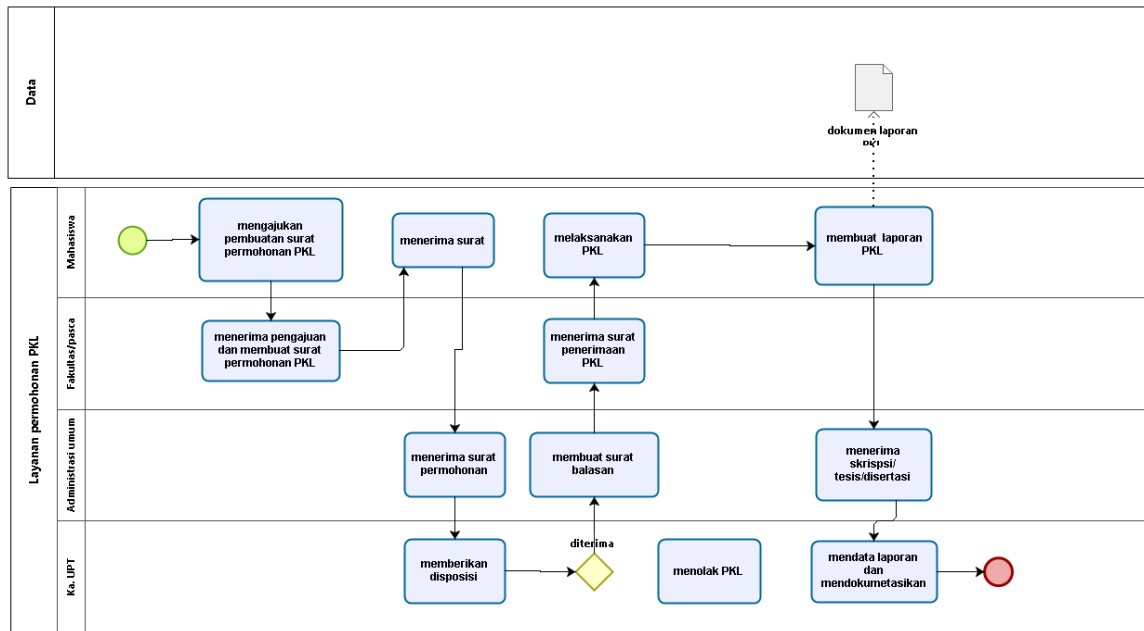

Powered by
bizagi
Modeler

Level 2 Layanan Pengambilan Data Skripsi / Tesis / Disertasi

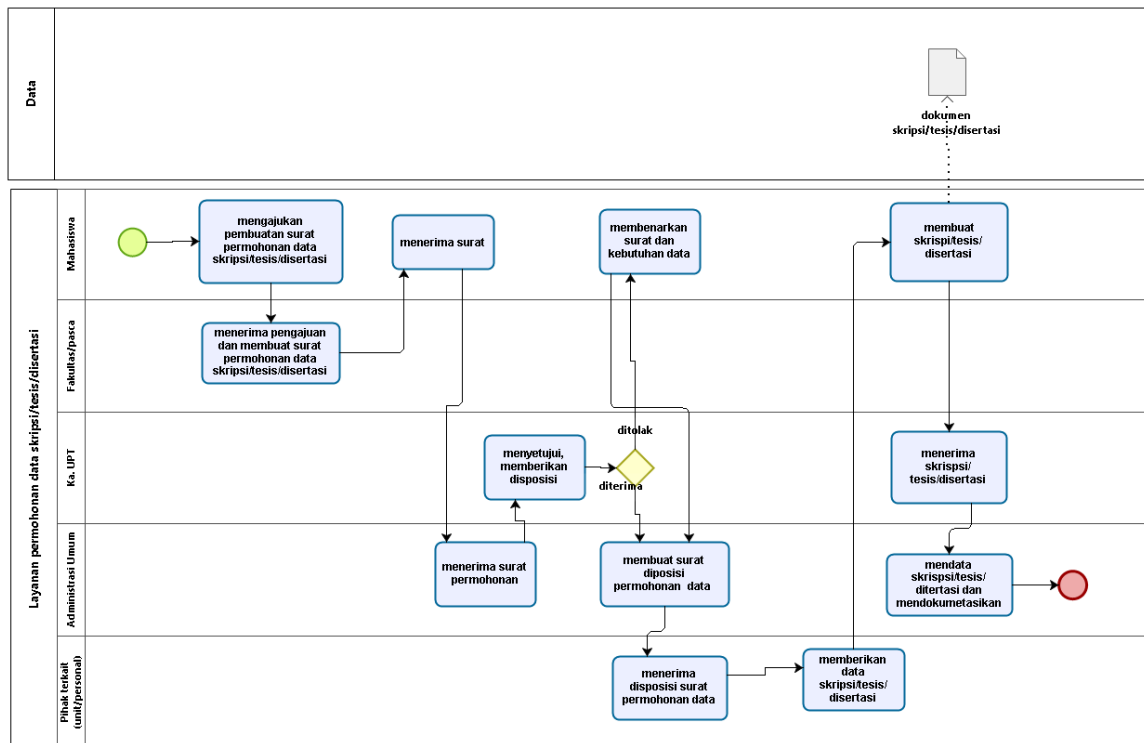

Powered by
bizagi
Modeler

Level 1 Layanan Kearsipan

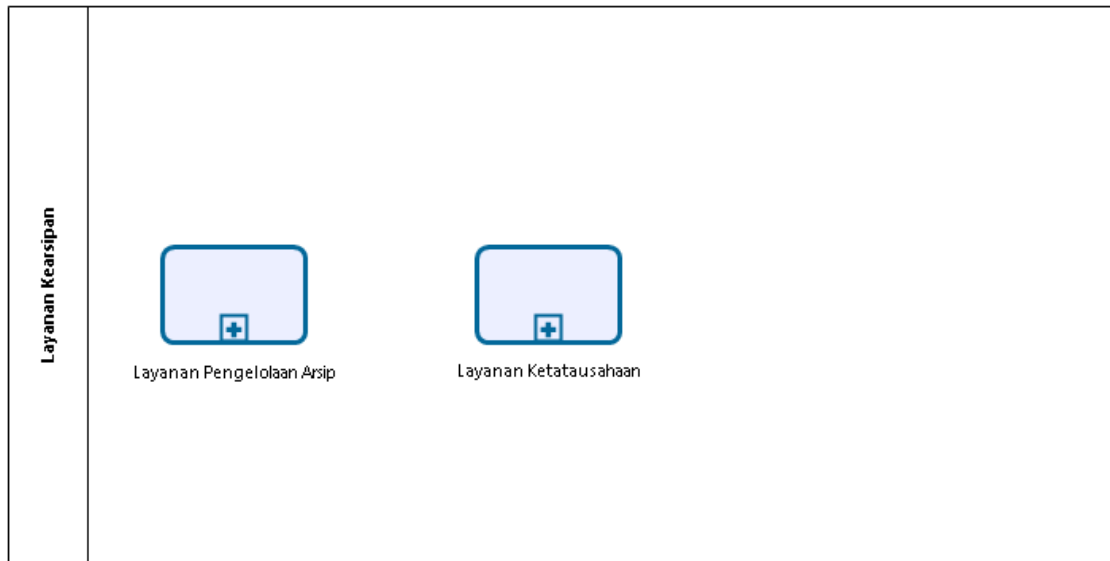

Powered by
bizagi
Modeler

Level 2 Layanan Pengelolaan Arsip

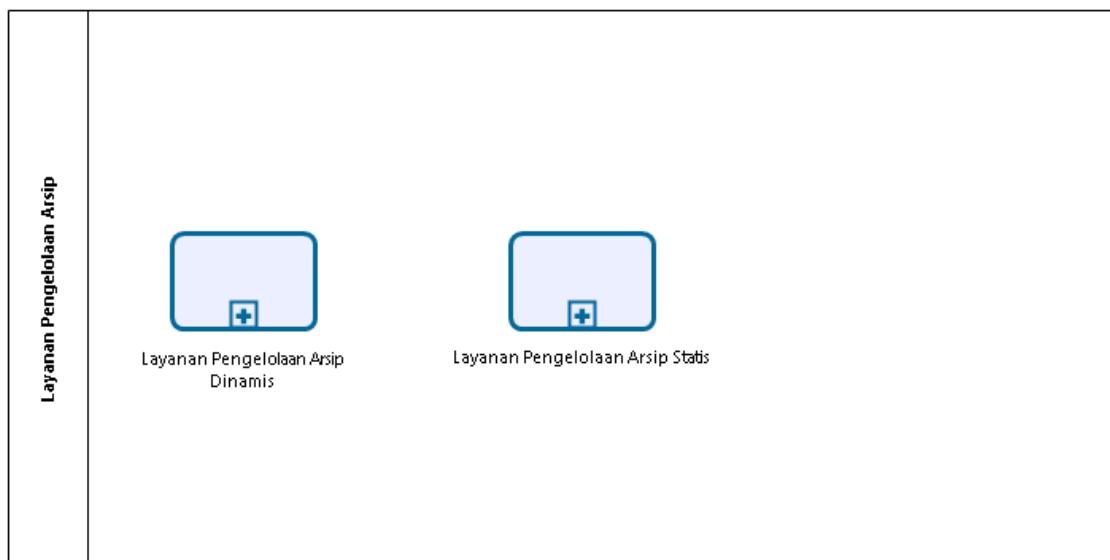

Powered by
bizagi
Modeler

Level 3 Layanan Pengelolaan Arsip Dinamis

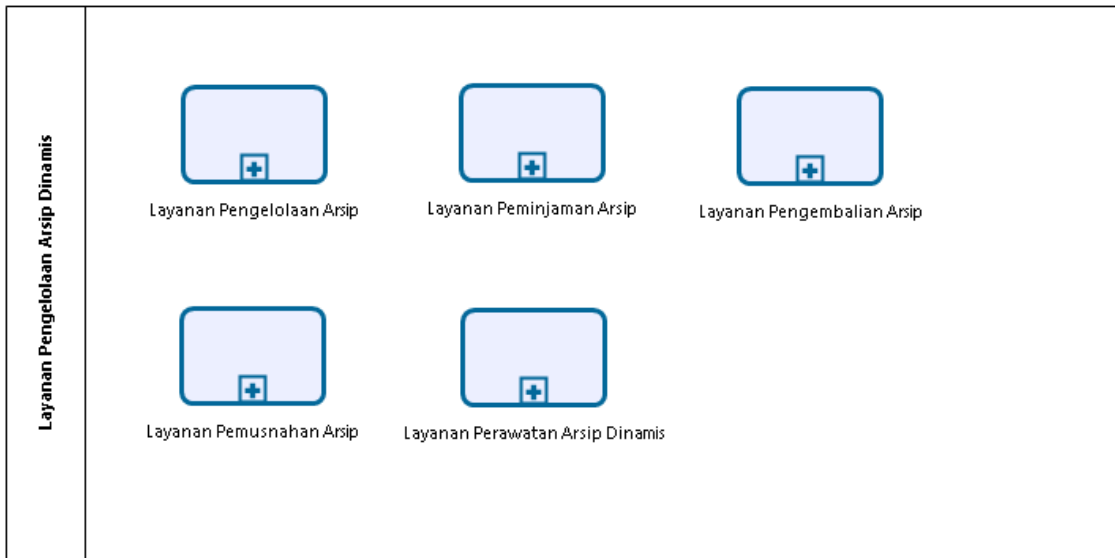

Powered by
bizagi
Modeler

Level 4 Layanan Pengelolaan Arsip

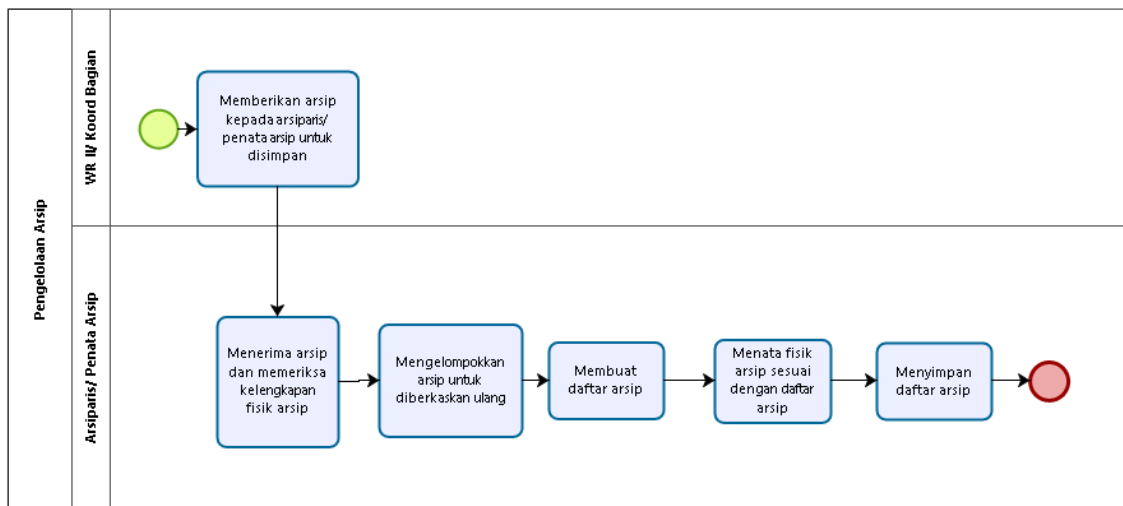

Powered by
bizagi
Modeler

Level 4 Layanan Peminjaman Arsip

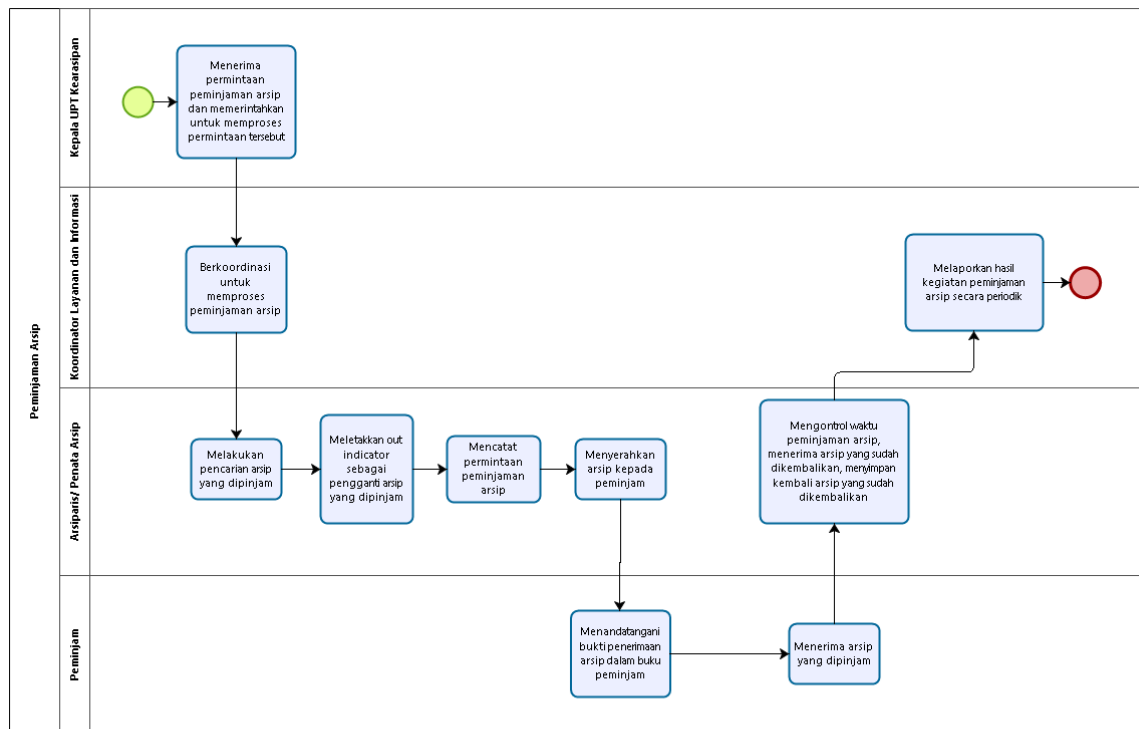

Level 4 Layanan Pengembalian Arsip

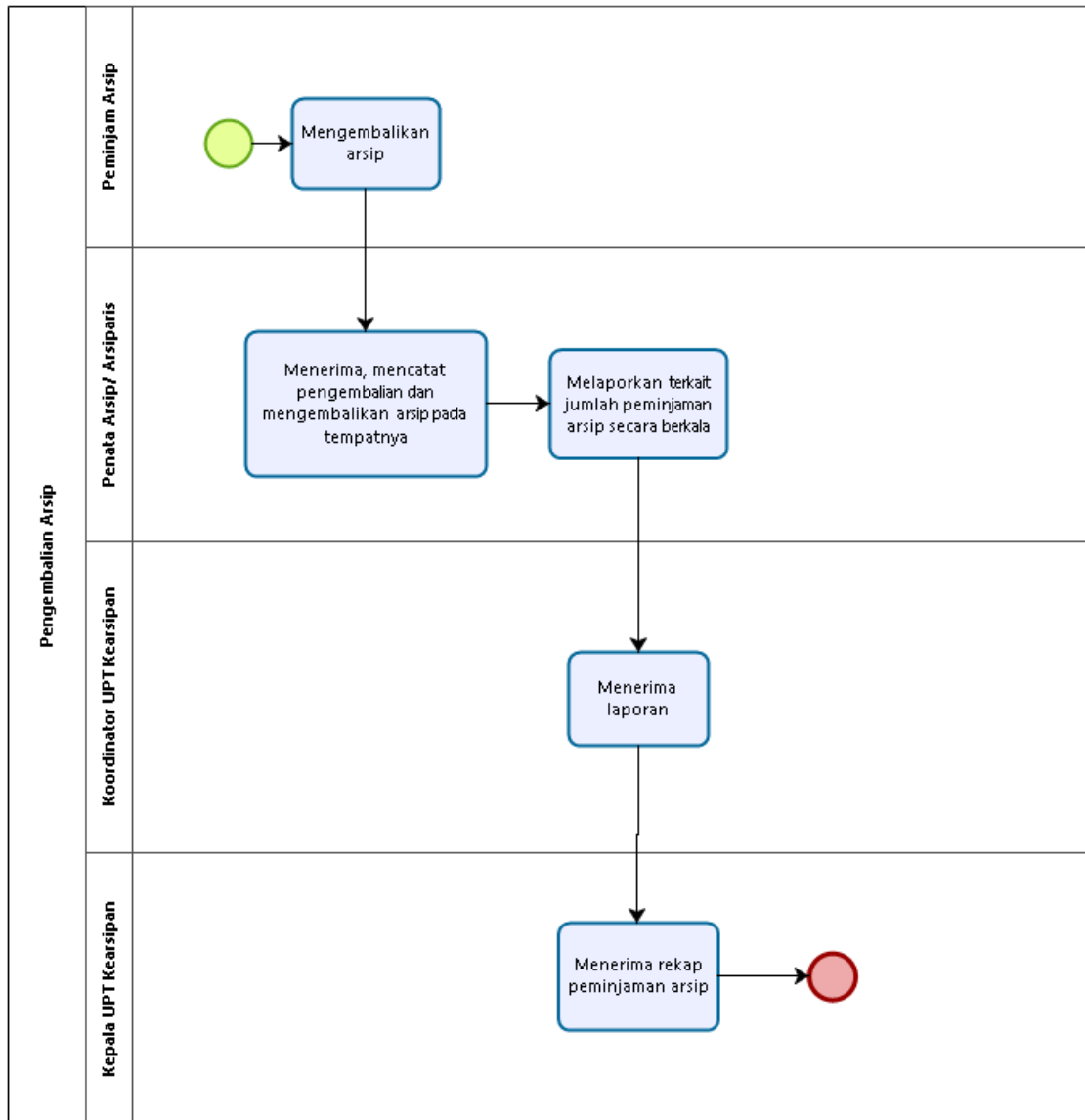

Level 4 Layanan Pemusnahan Arsip

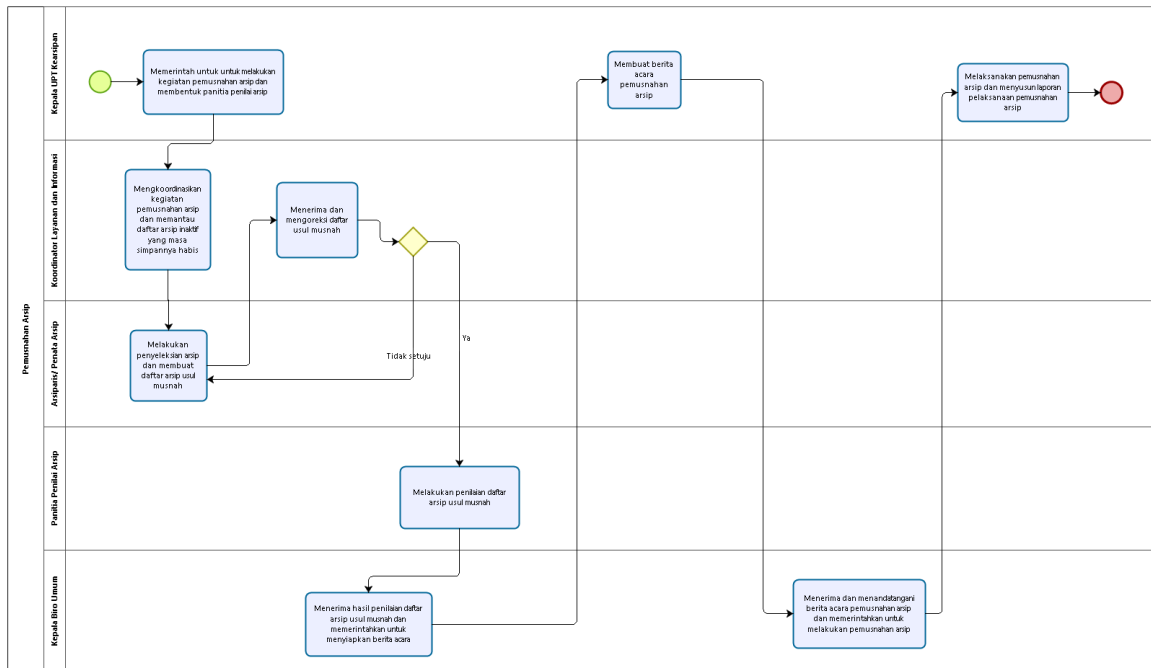

Level 4 Layanan Perawatan Arsip Dinamis

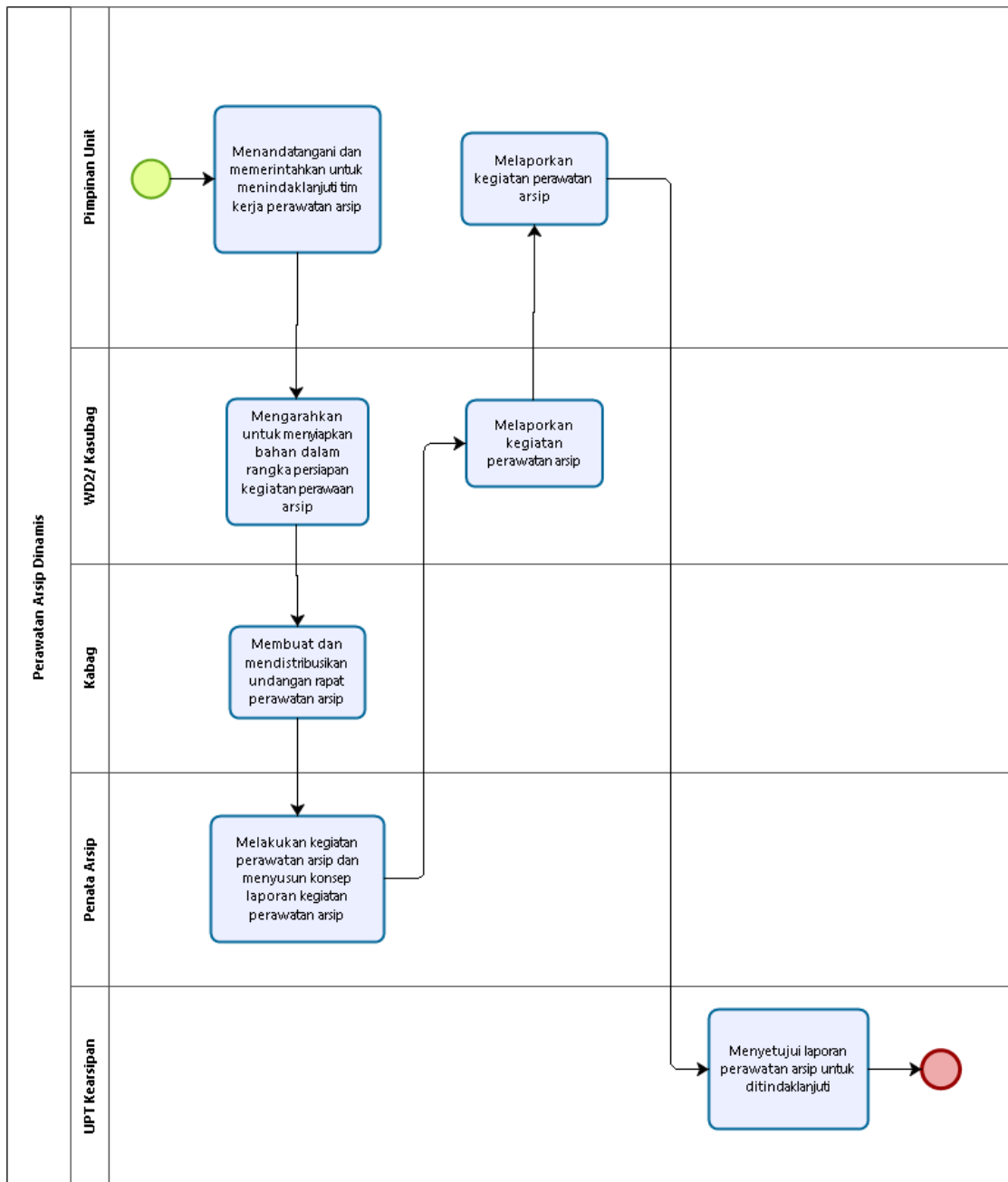

Level 3 Layanan Pengelolaan Arsip Statis

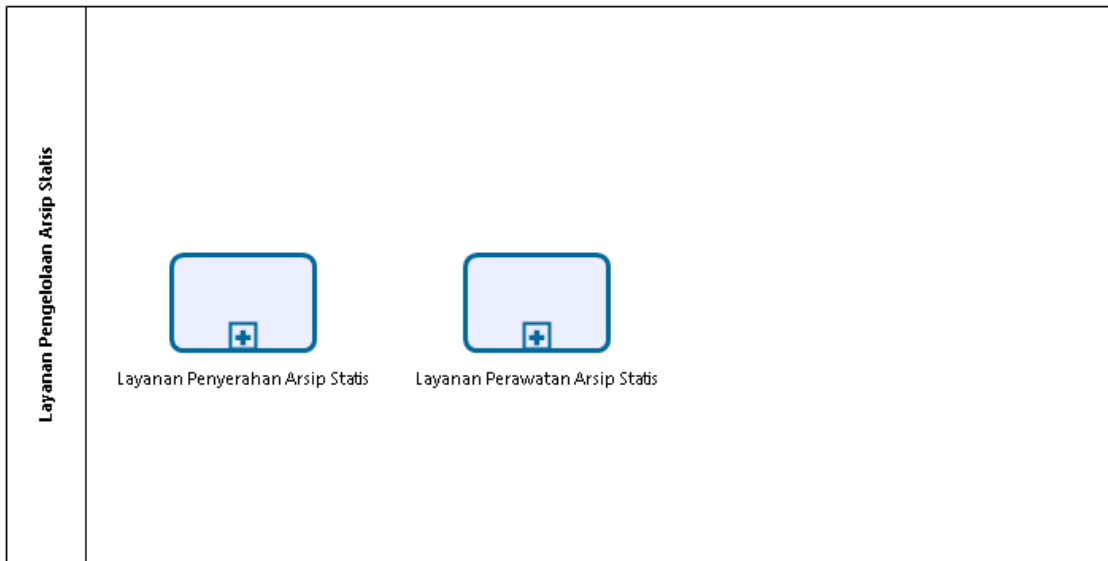

Level 4 Layanan Penyerahan Arsip Statis

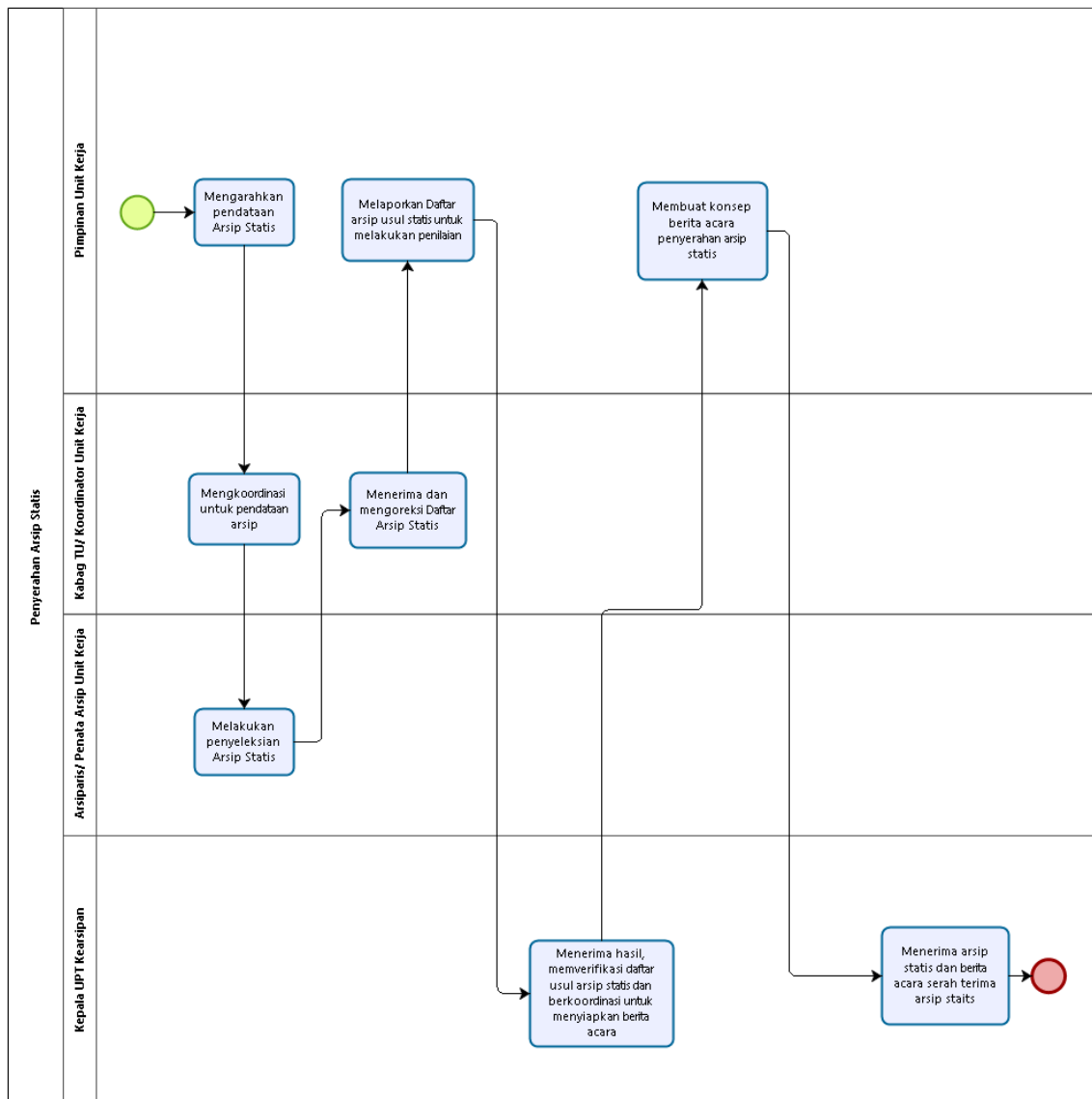

Level 4 Layanan Perawatan Arsip Statis

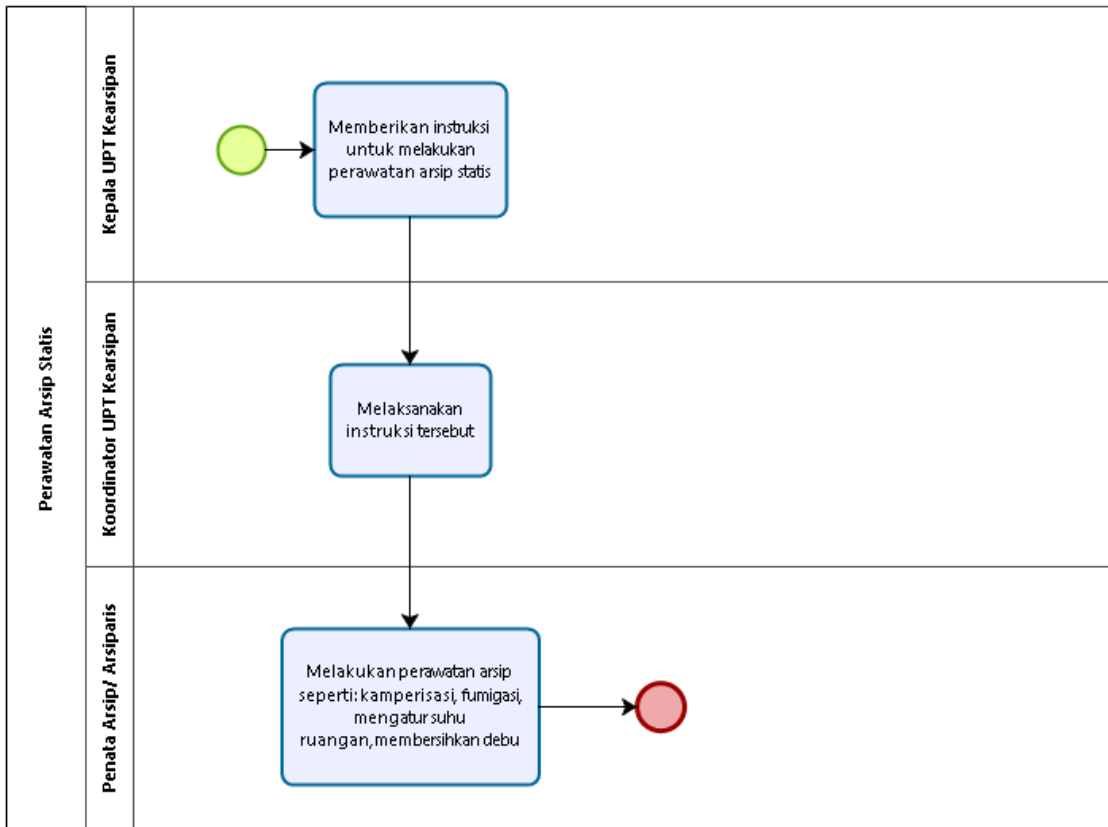

Level 2 Layanan Ketatausahaan

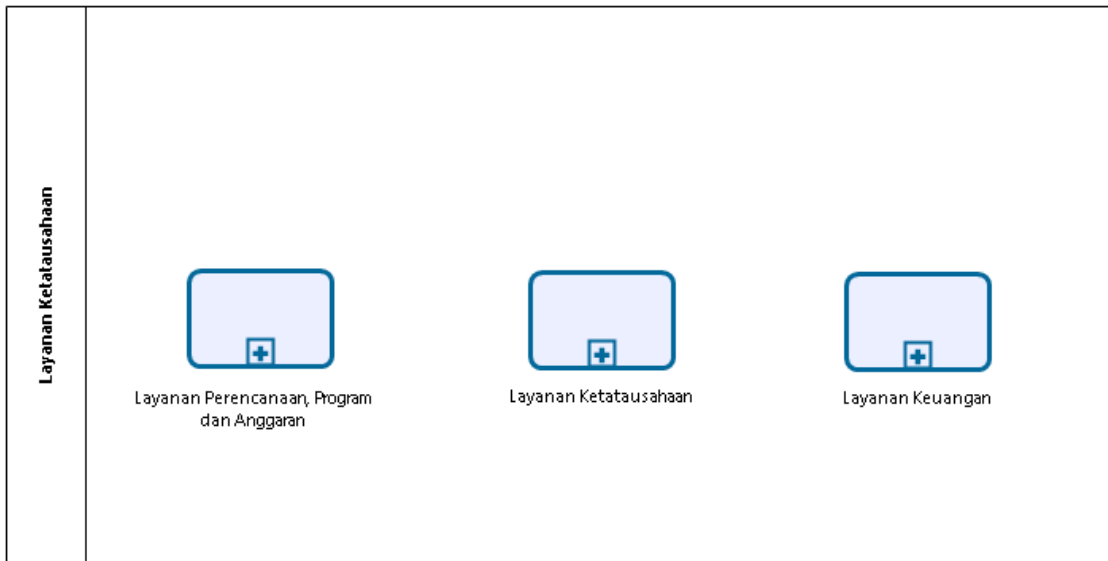

Powered by
bizagi
Modeler

Level 3 Layanan Perencanaan, Program dan Anggaran

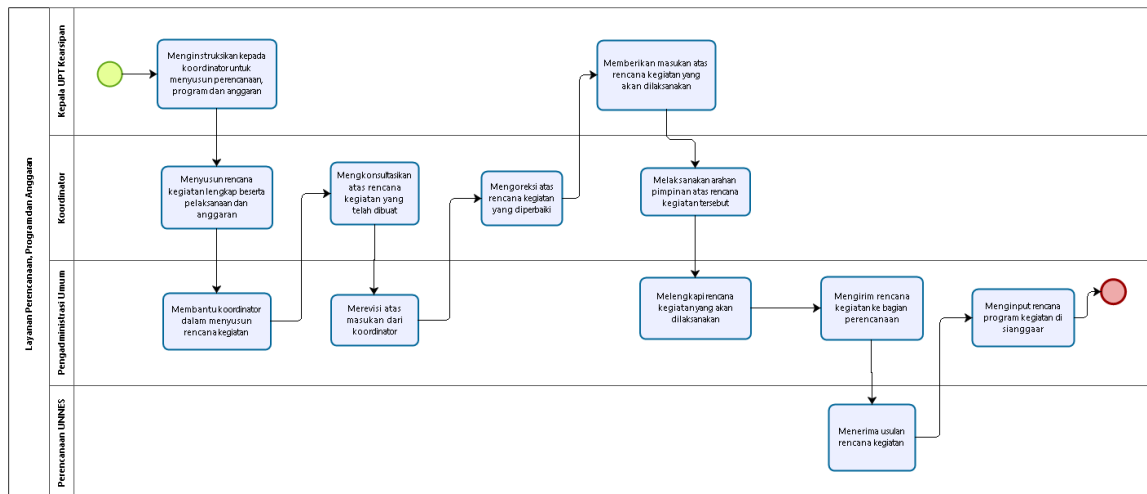

Powered by
bizagi
Modeler

Level 3 Layanan Ketatausahaan

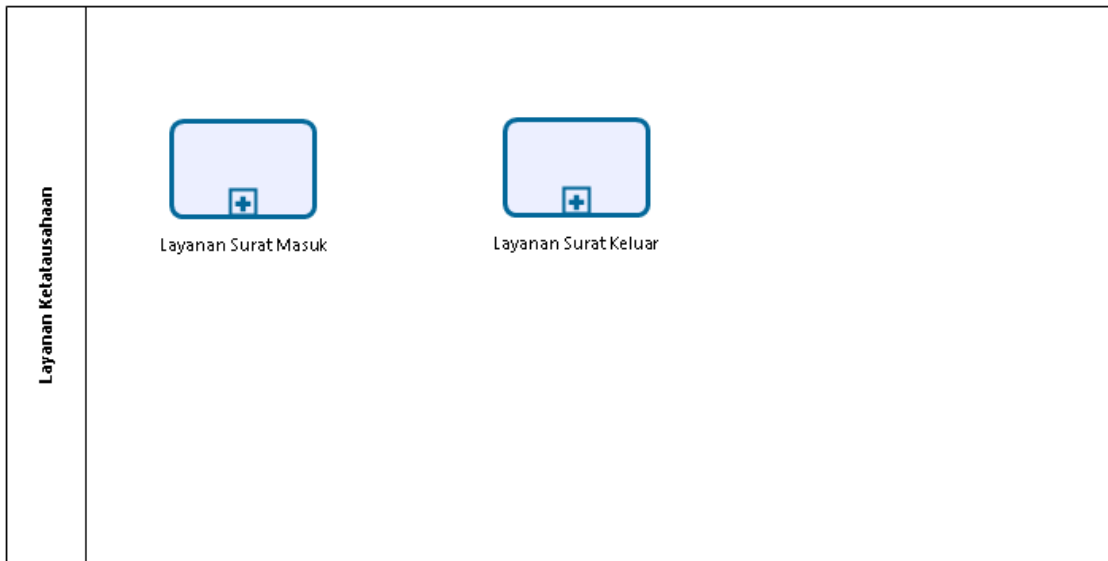

Powered by
bizagi
Modeler

Level 4 Layanan Surat Masuk UPT Kearsipan

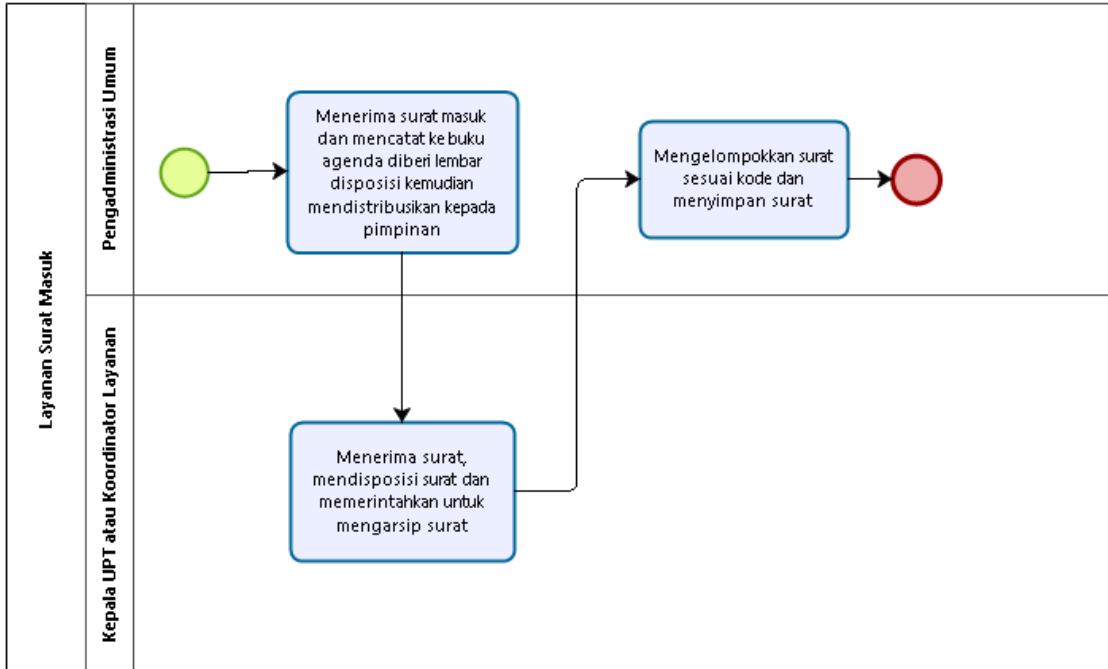

Powered by
bizagi
Modeler

Level 4 Layanan Surat Keluar UPT Kearsipan

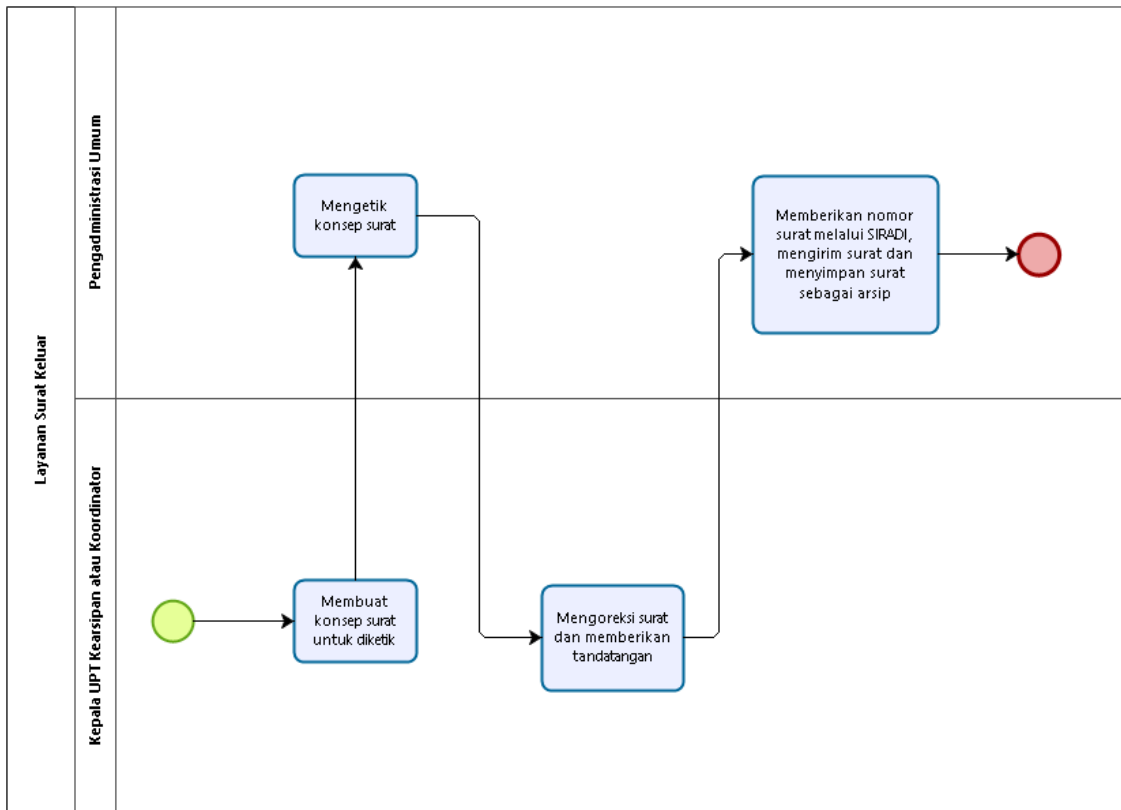

Level 3 Layanan Keuangan

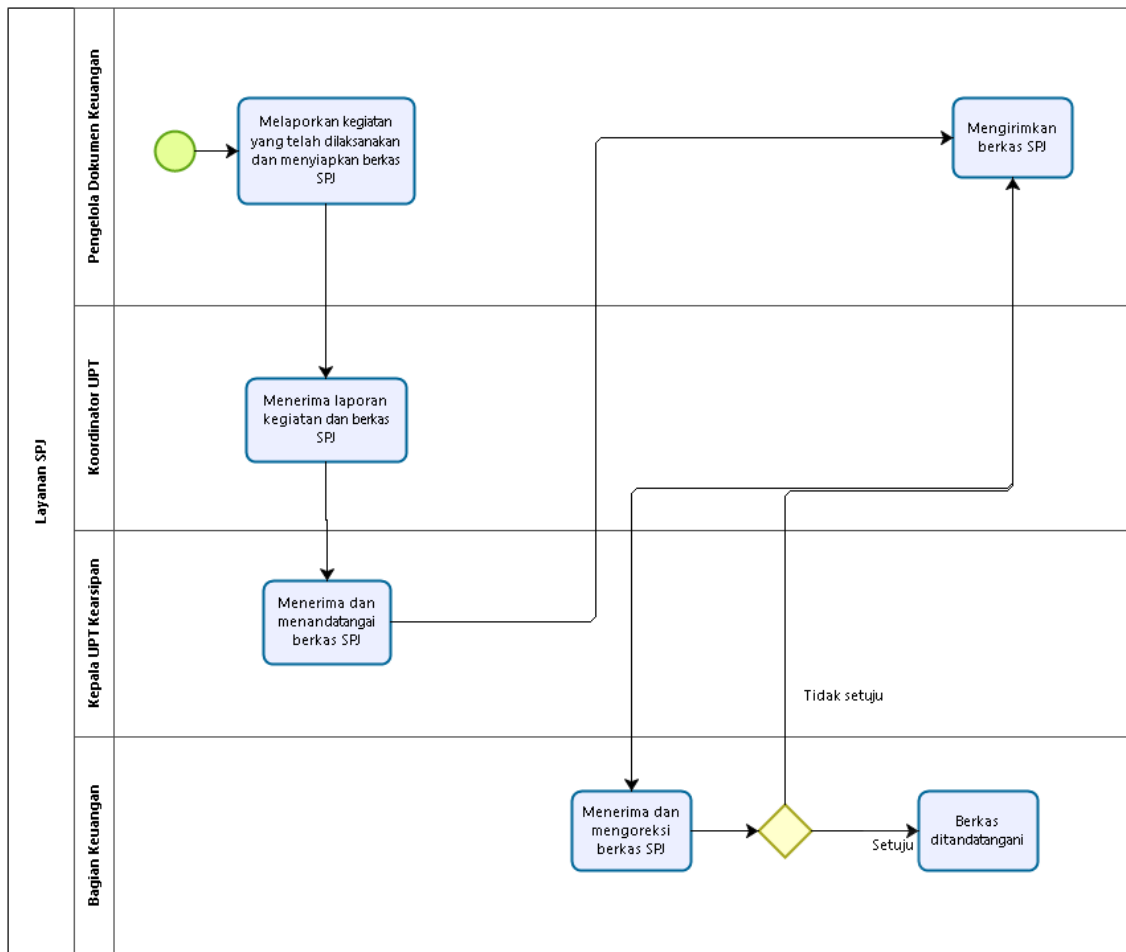

Level 1 Layanan Hubungan Masyarakat



Powered by
bizagi
Modeler

Level 2 Layanan Informasi

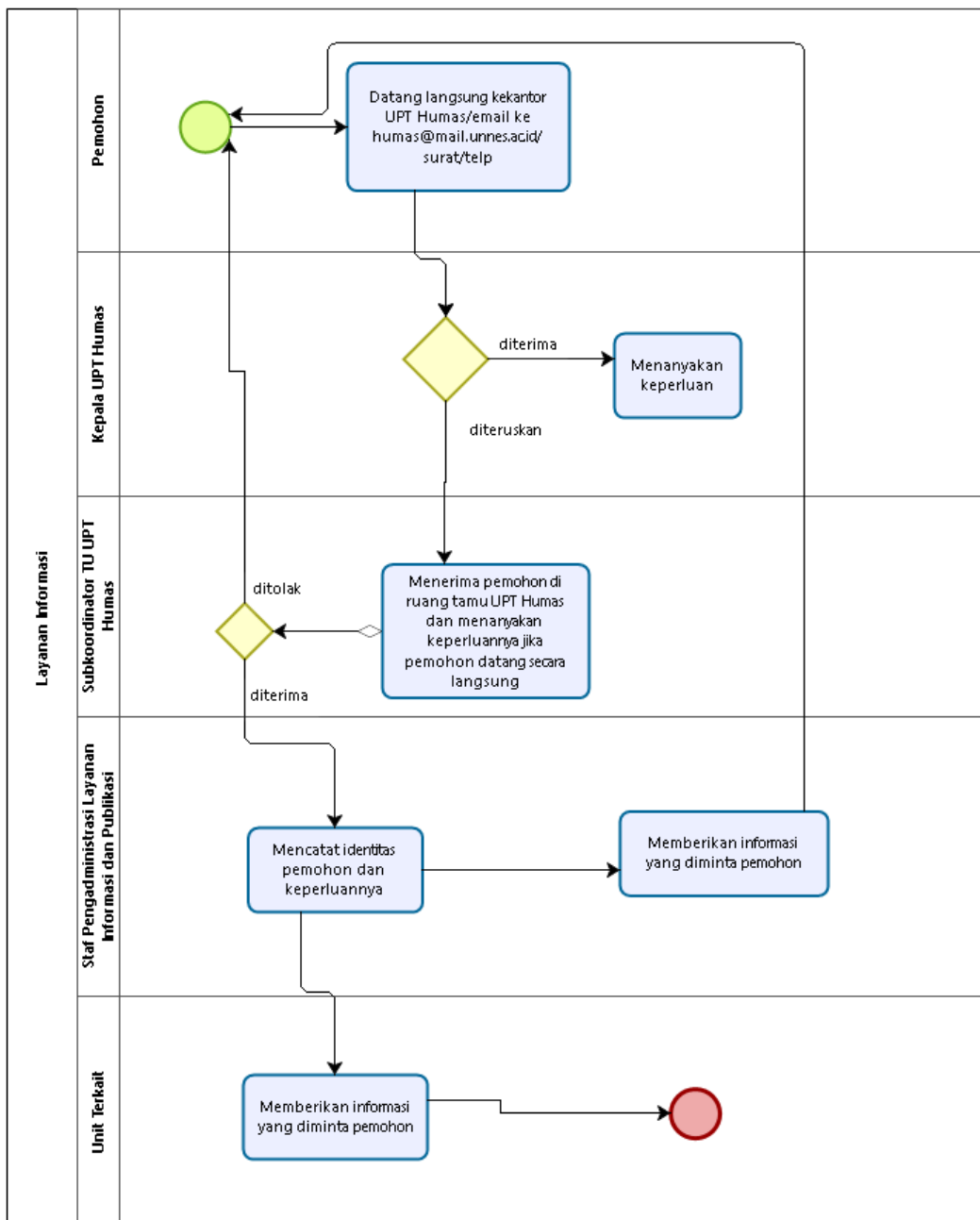

Level 2 Layanan Peliputan Berita

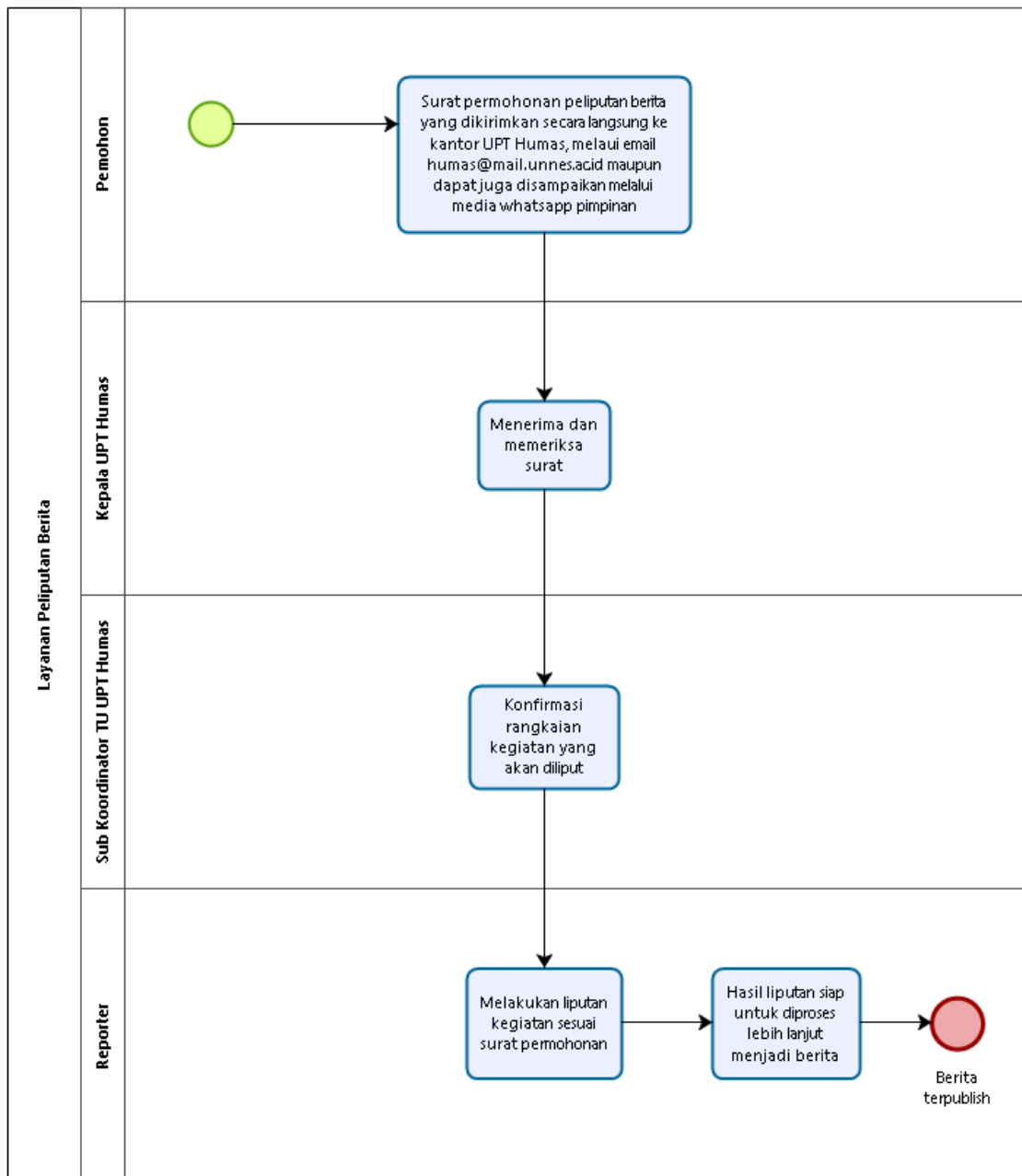

Level 2 Layanan Unggah Berita, Pengumuman, Videotron

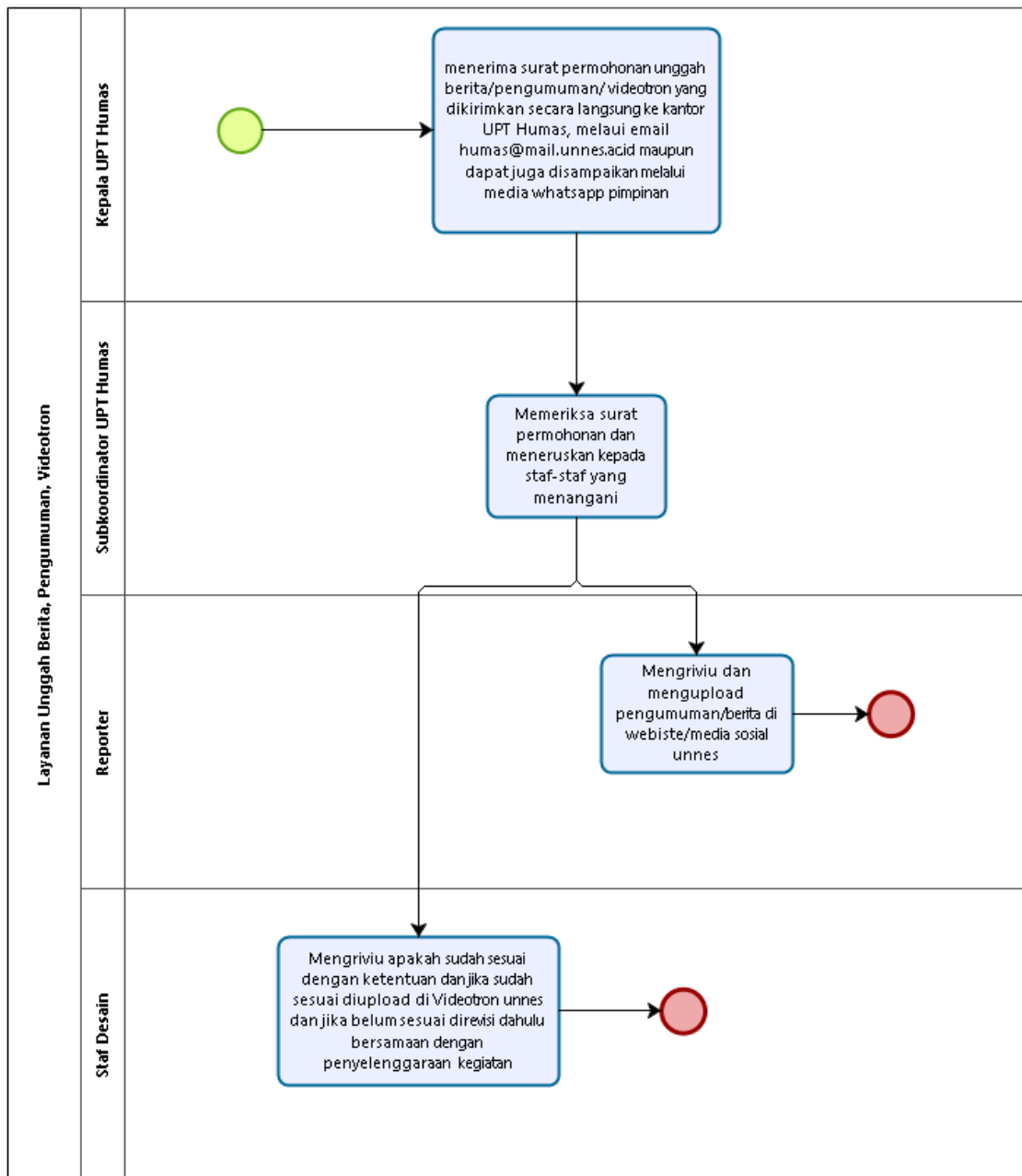

Level 2 Layanan Press Conference

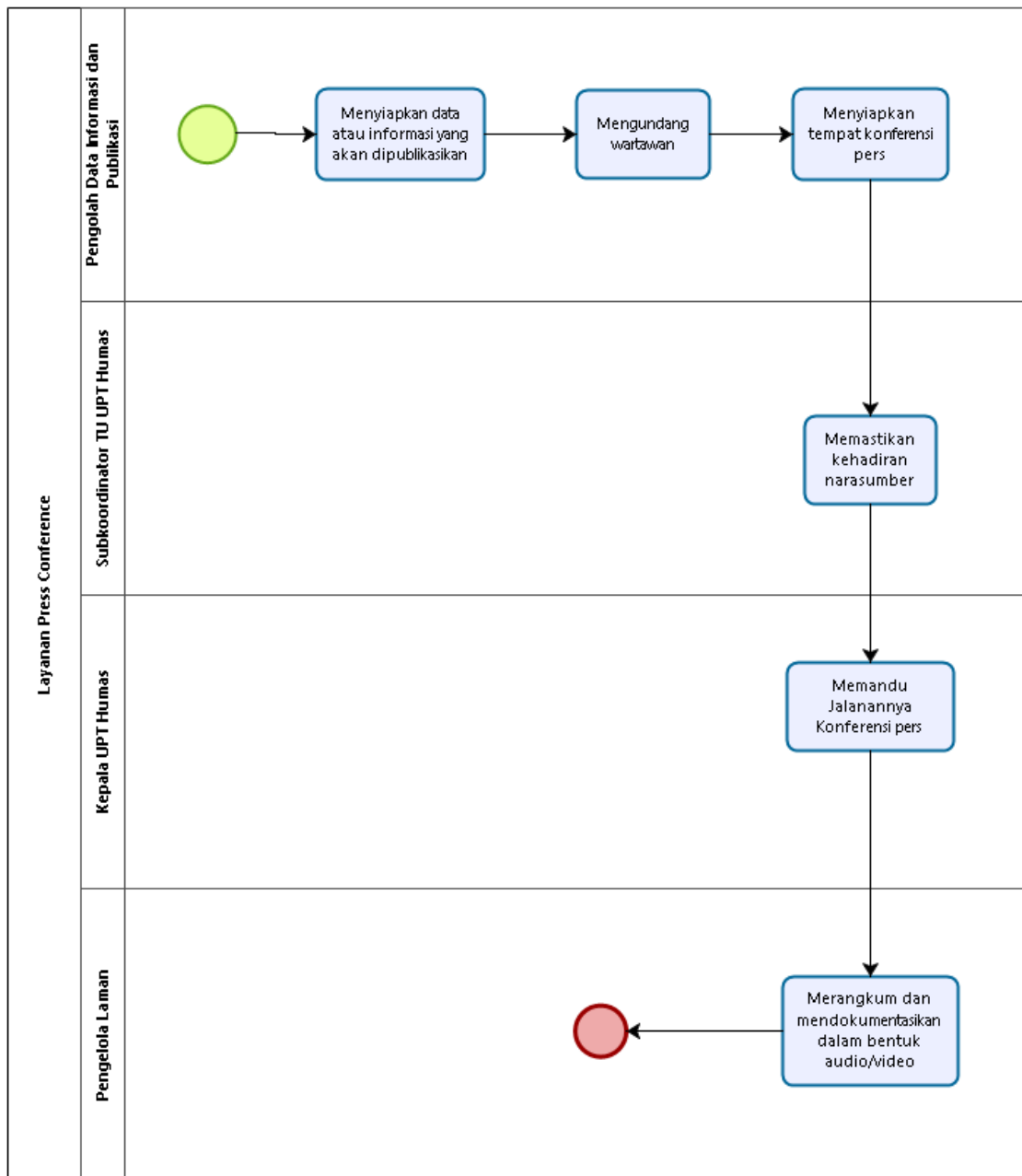

Level 2 Layanan Pengaduan Publik

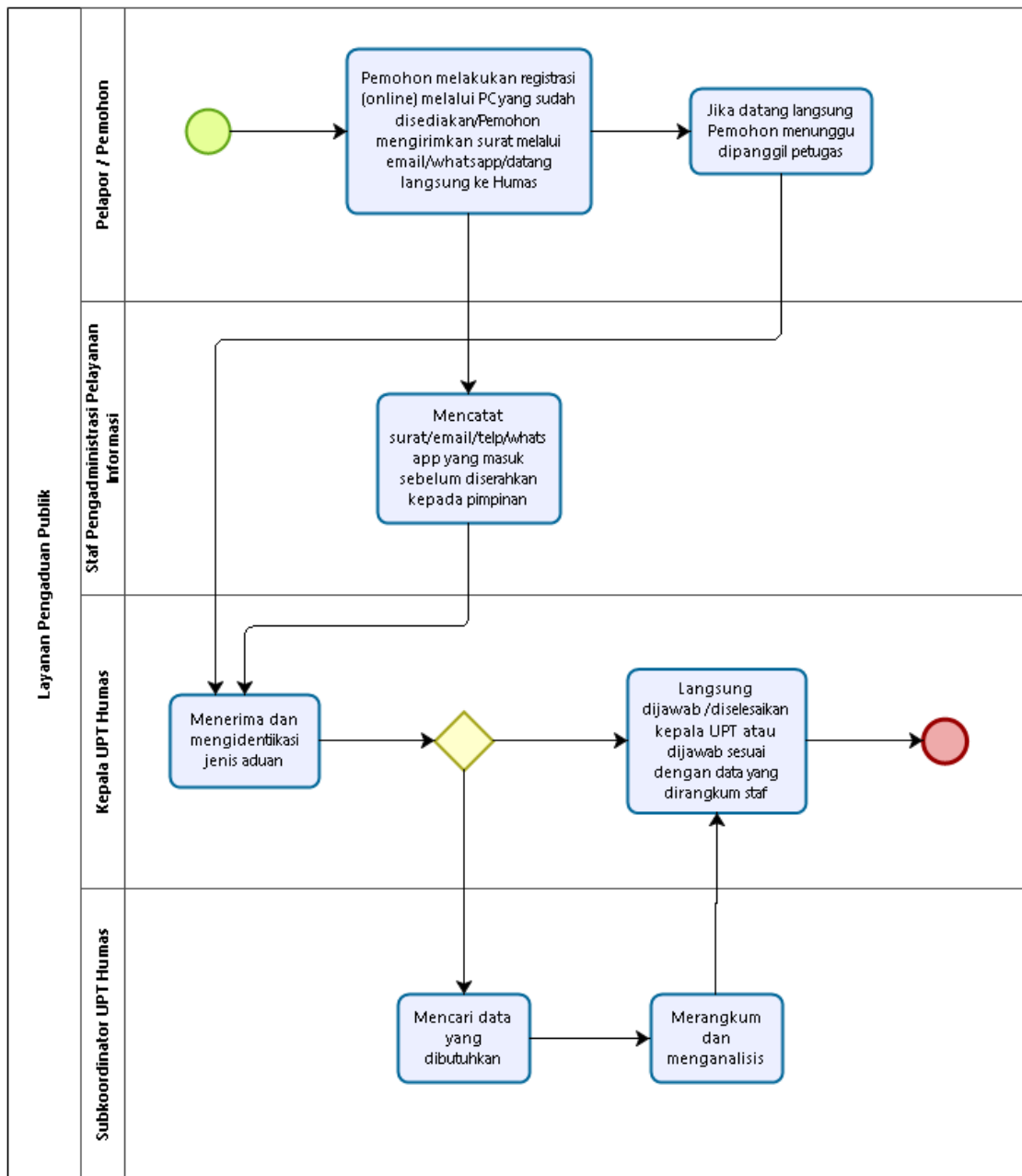

Level 2 Layanan Surat Masuk

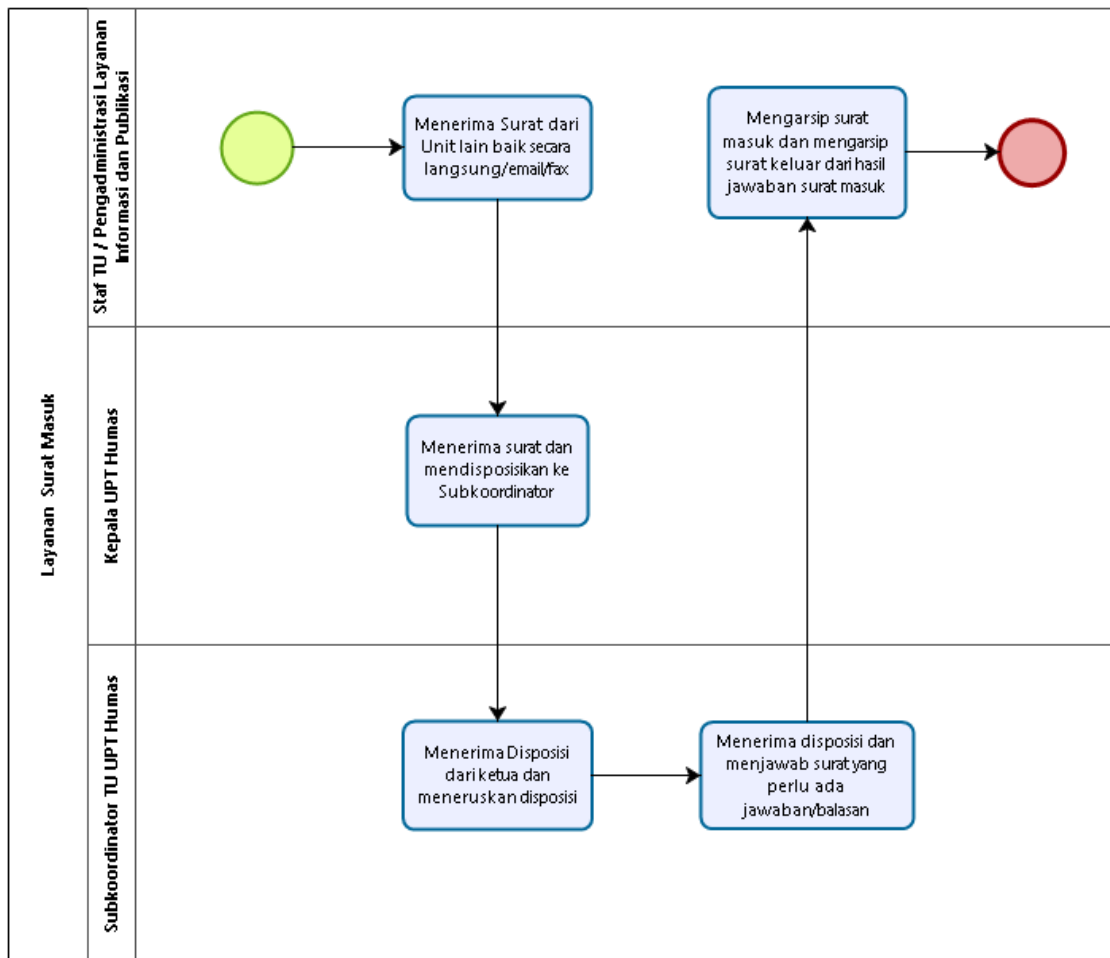

Level 2 Layanan Surat Keluar

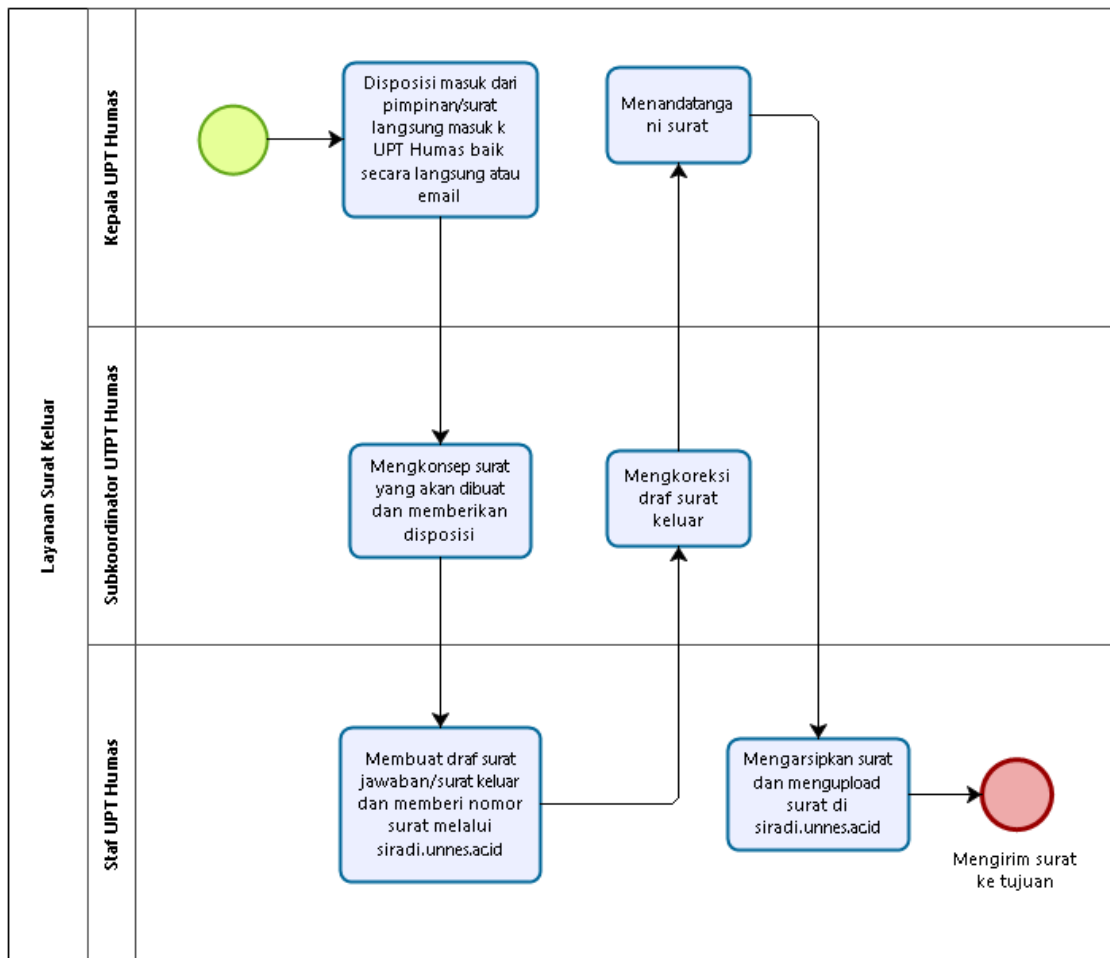

Level 2 Layanan Penyusunan Program dan Anggaran

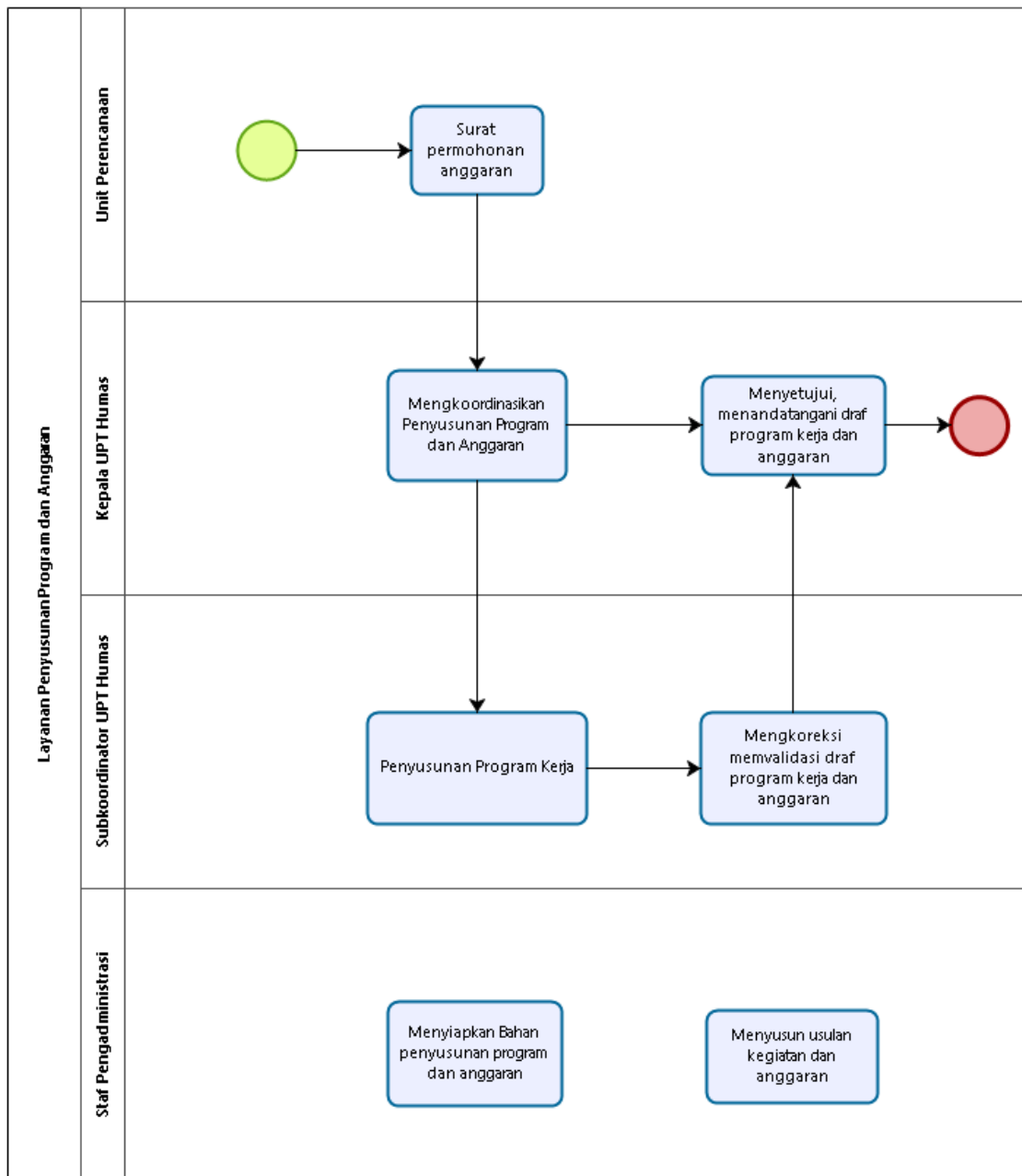



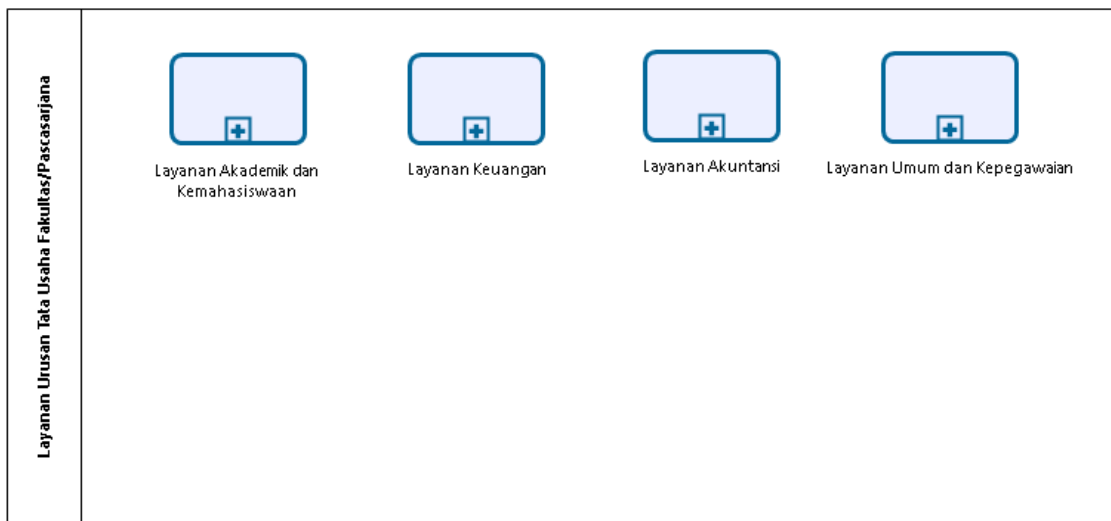











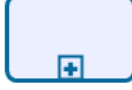

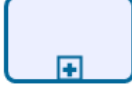

Level 1 Layanan Urusan Tata Usaha Fakultas / Pascasarjana



Powered by
bizagi
Modeler

Level 2 Layanan Akademik dan Kemahasiswaan Fakultas / Pascasarjana

Layanan Akademik dan Kemahasiswaan Fakultas/Pascasarjana	Layanan Inti				
		Layanan Pembimbingan Akademik	Layanan Penyusunan Kurikulum	Layanan Penyusunan Rencana Pembelajaran Semester (RPS)	Layanan Penyusunan Bahan Ajar
					
		Layanan Penyusunan Layanan Jurnal Ilmiah	Layanan Pembimbingan Skripsi	Layanan Pelaksanaan Ujian Skripsi	Layanan Penggunaan Laboratorium Komputer
					
		Layanan Penetapan Jadwal Kuliah	Layanan Evaluasi Kurikulum	Layanan Pelaksanaan Ujian Akhir Semester	Layanan Pelaksanaan Kuliah Kerja Lapangan (KKL)
					
		Layanan Pelaksanaan Praktik Kerja Lapangan (PKL)	Layanan UNNES LANTIP	Layanan UNNES PRIGEL	Layanan UNNES GIAT
	Layanan Pendukung				
		Layanan Peminjaman Fasilitas Laboratorium	Layanan Pelatihan	Layanan Akses Data	Layanan Surat Aktif Kuliah, dll

Level 3 Layanan Pembimbingan Akademik

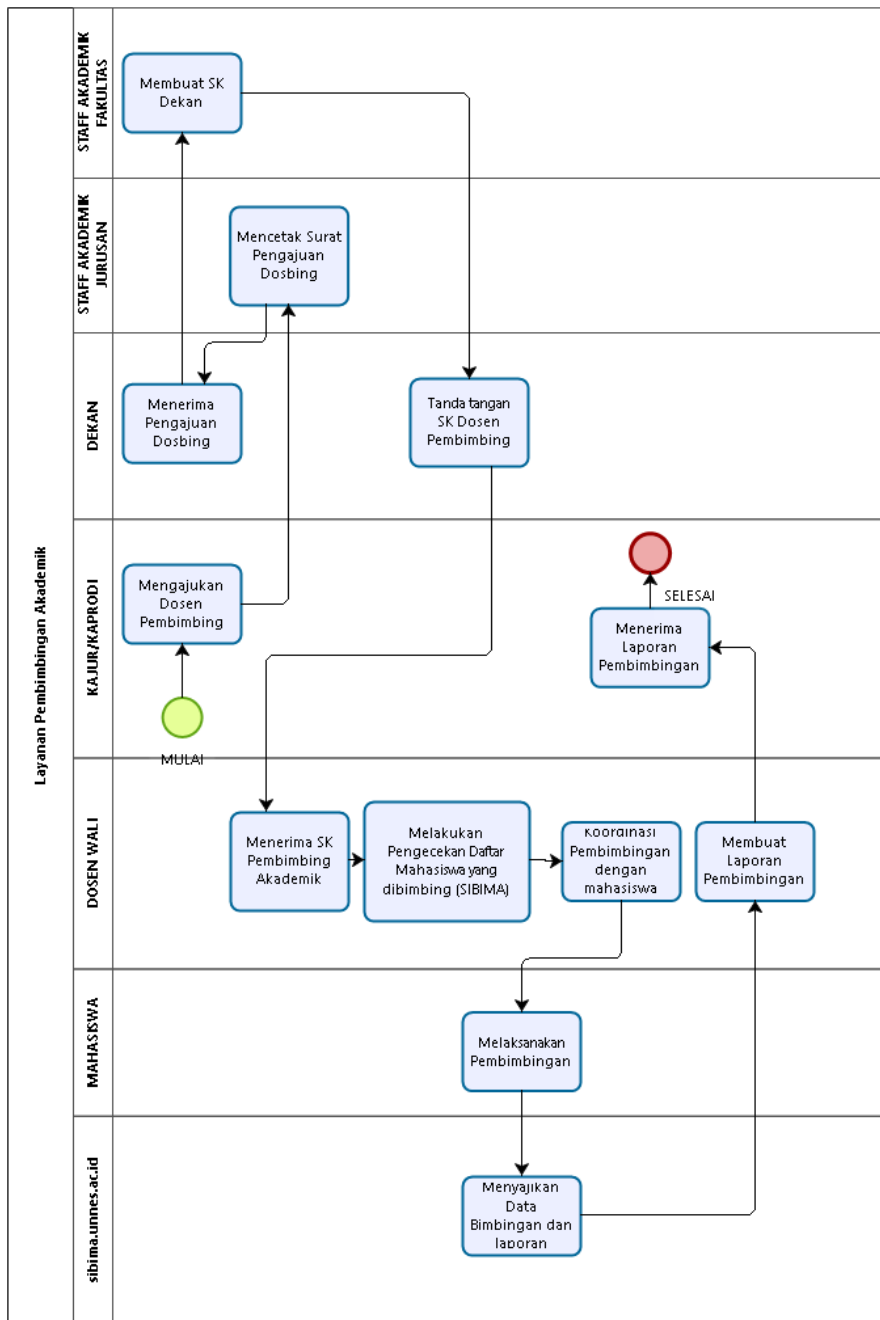

Level 3 Layanan Penyusunan Kurikulum

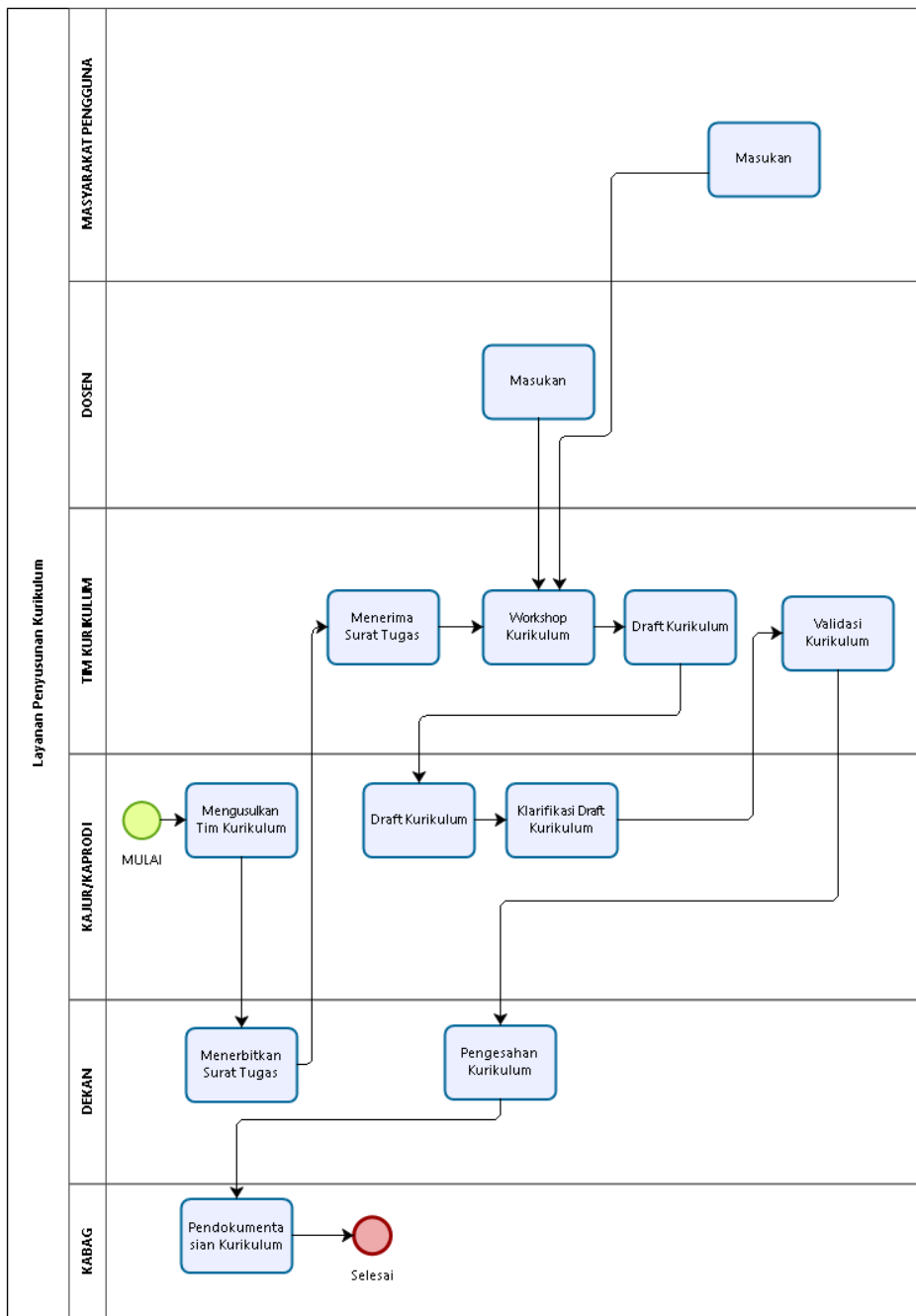

Level 3 Layanan Penyusunan Rencana Pembelajaran Semester (RPS)

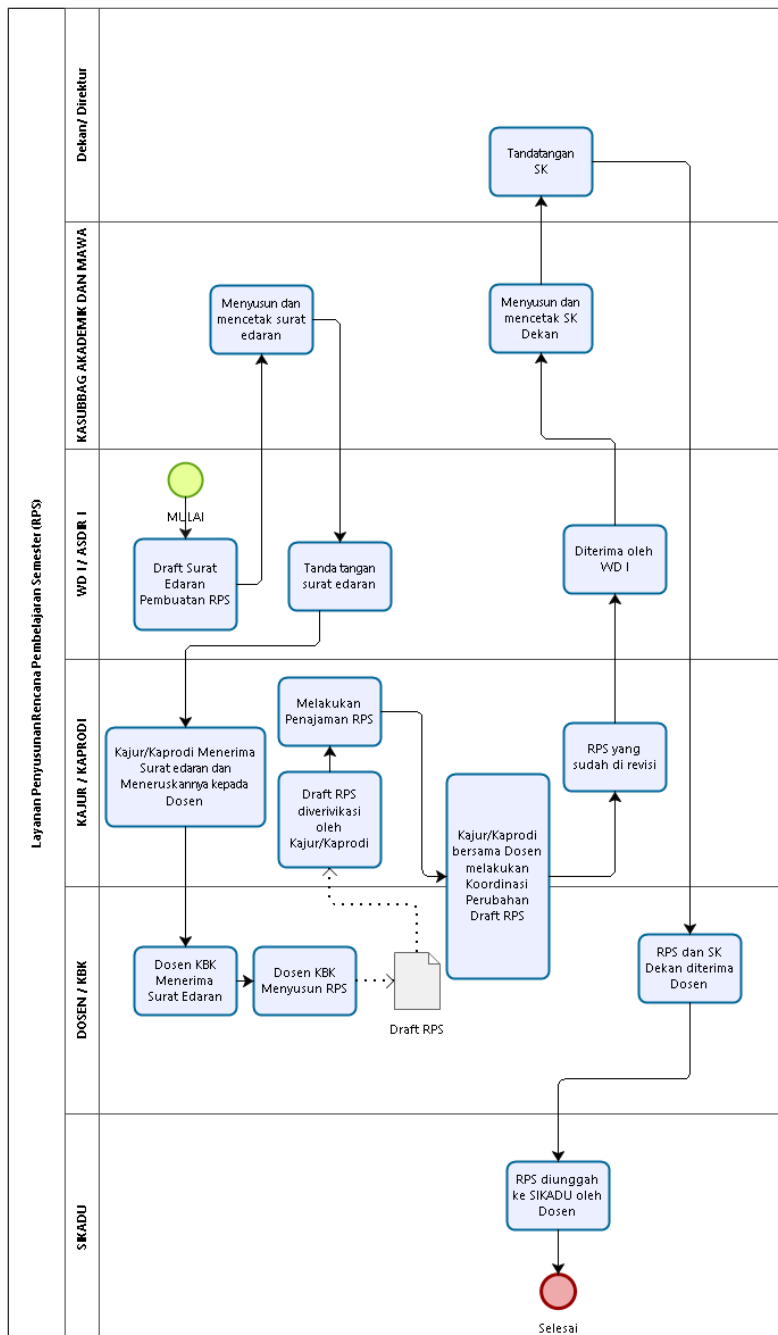

Level 3 Layanan Penyusunan Bahan Ajar

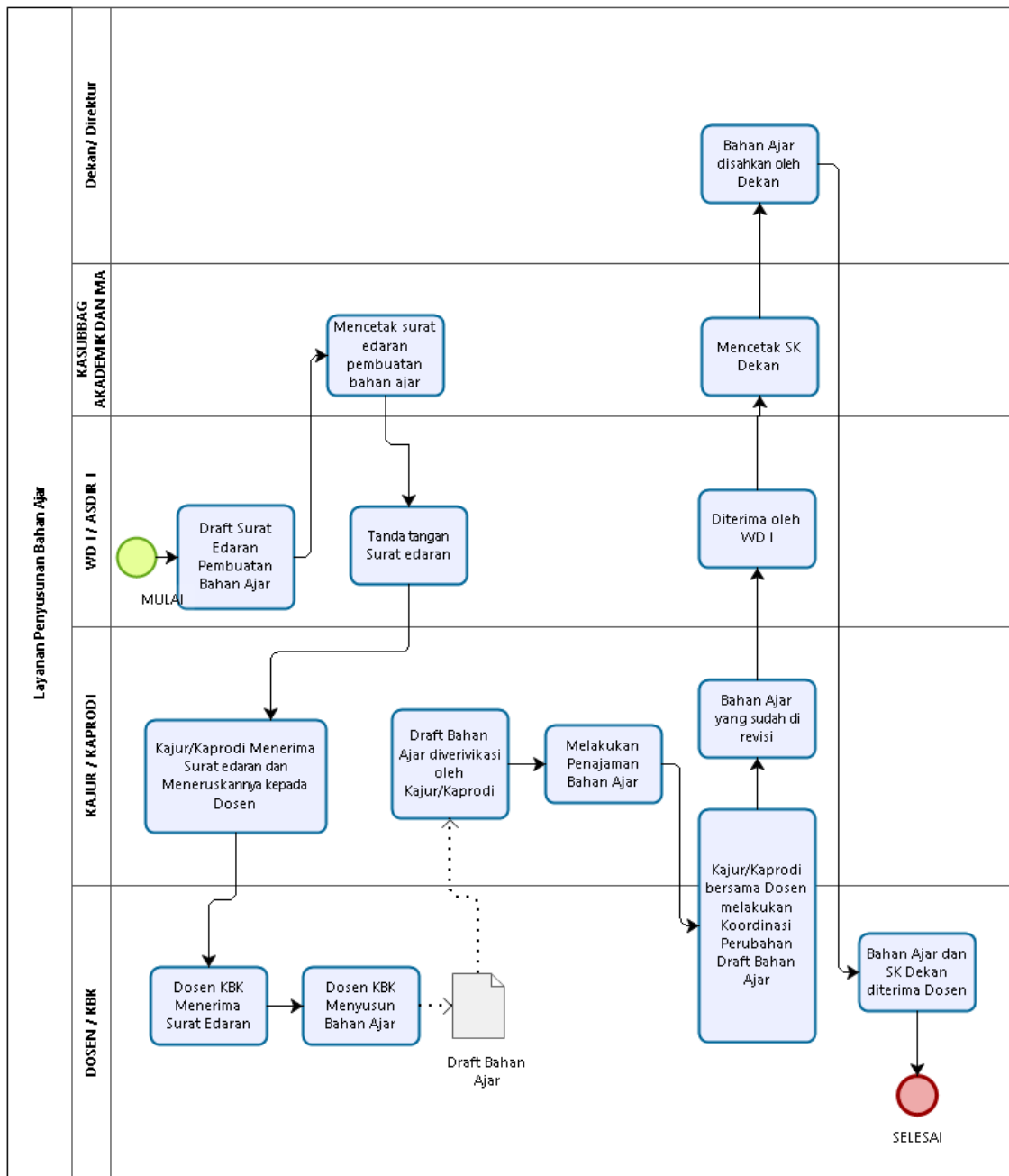

Level 3 Layanan Penyusunan Layanan Jurnal Ilmiah

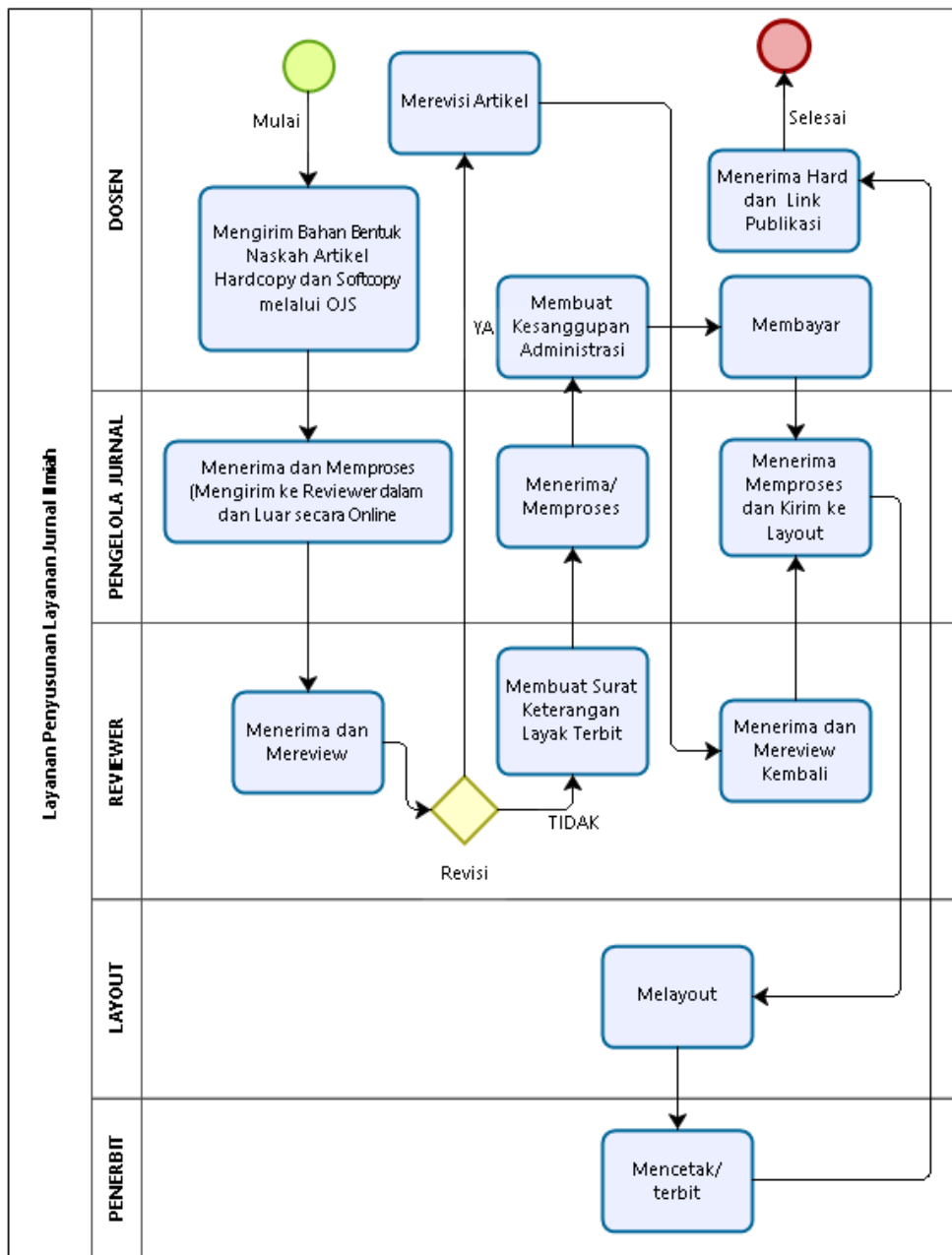

Level 3 Layanan Pelaksanaan Ujian Skripsi

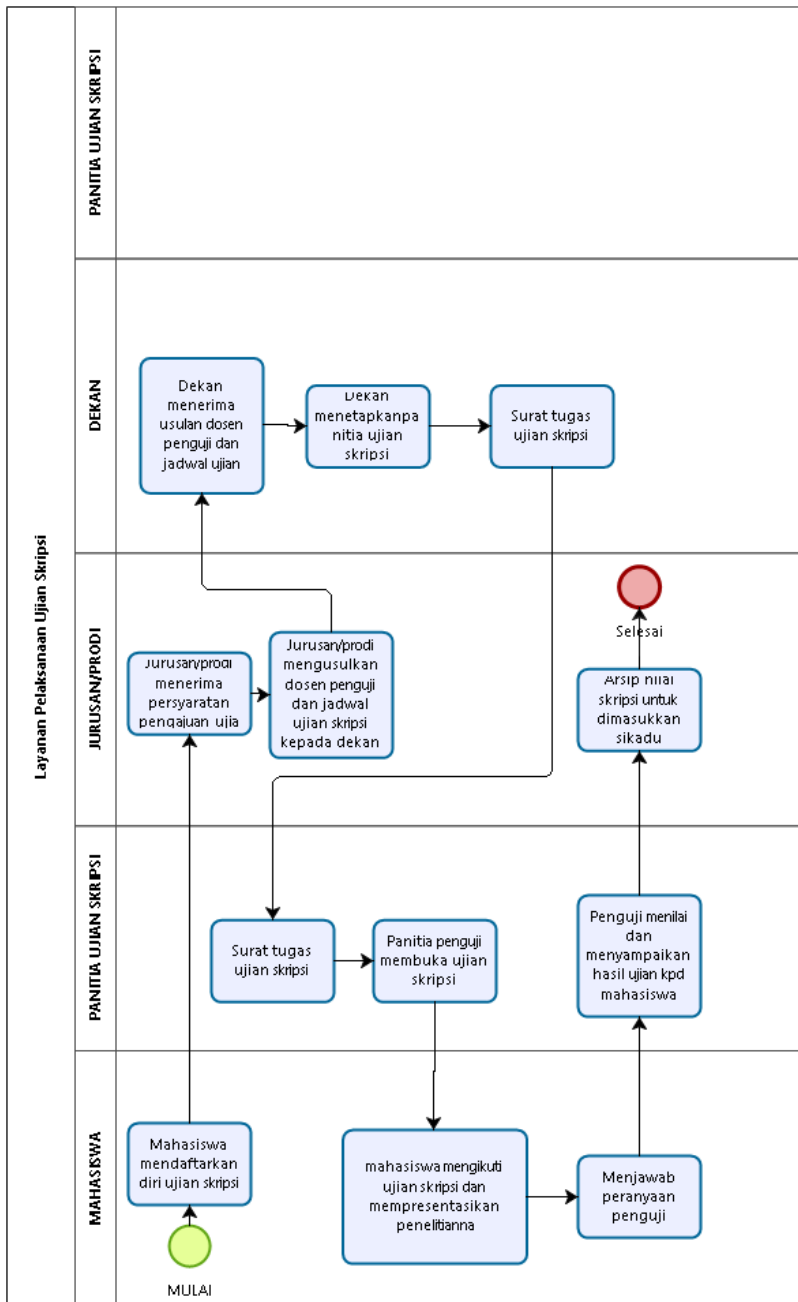

Level 3 Layanan Penggunaan Laboratorium Komputer

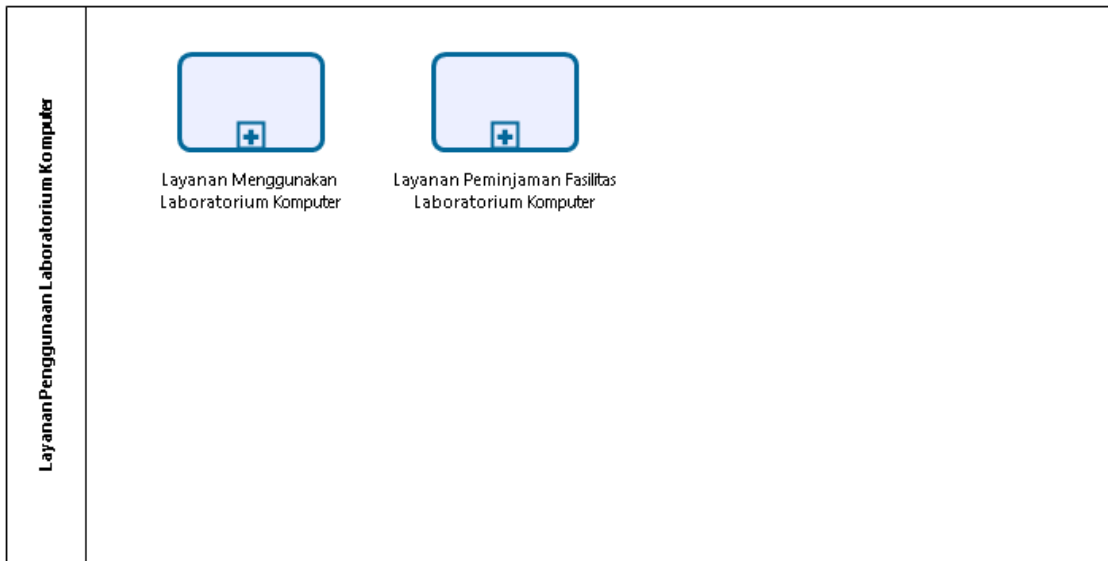

Level 4 Layanan Menggunakan Laboratorium Komputer

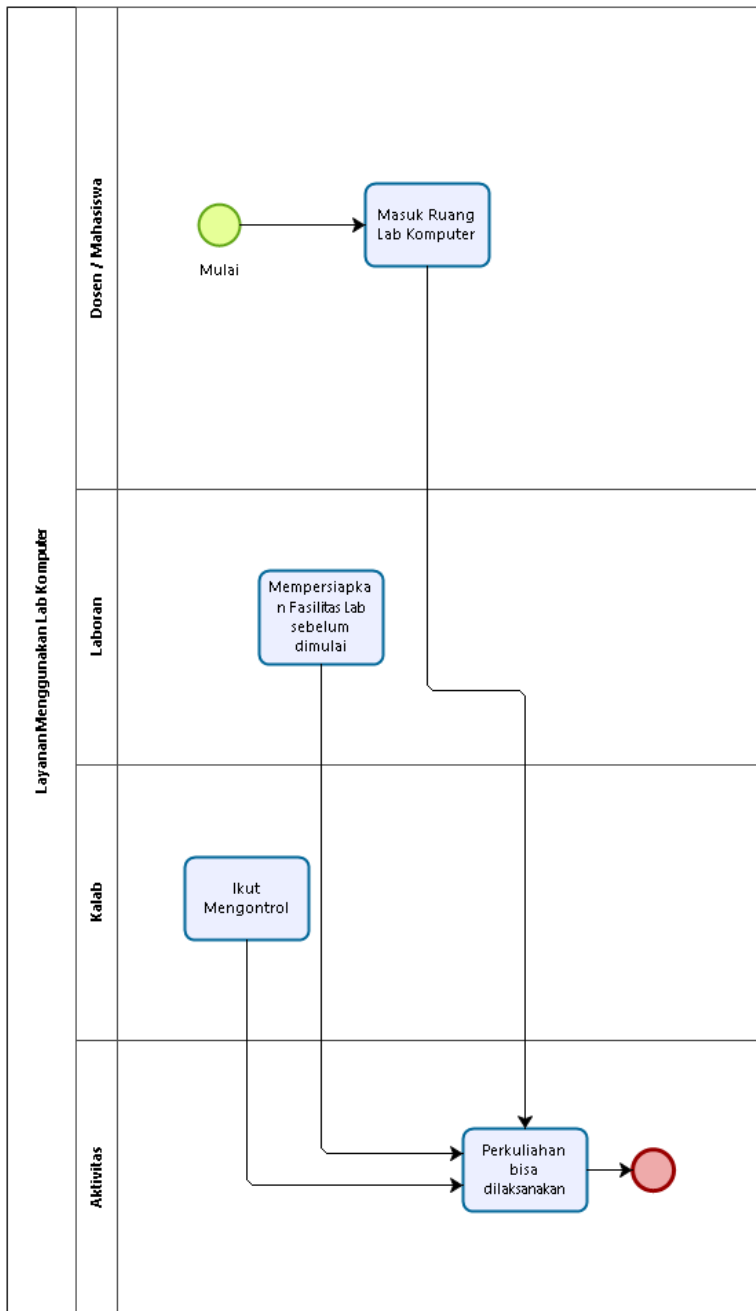

Level 4 Layanan Peminjaman Fasilitas Laboratorium Komputer

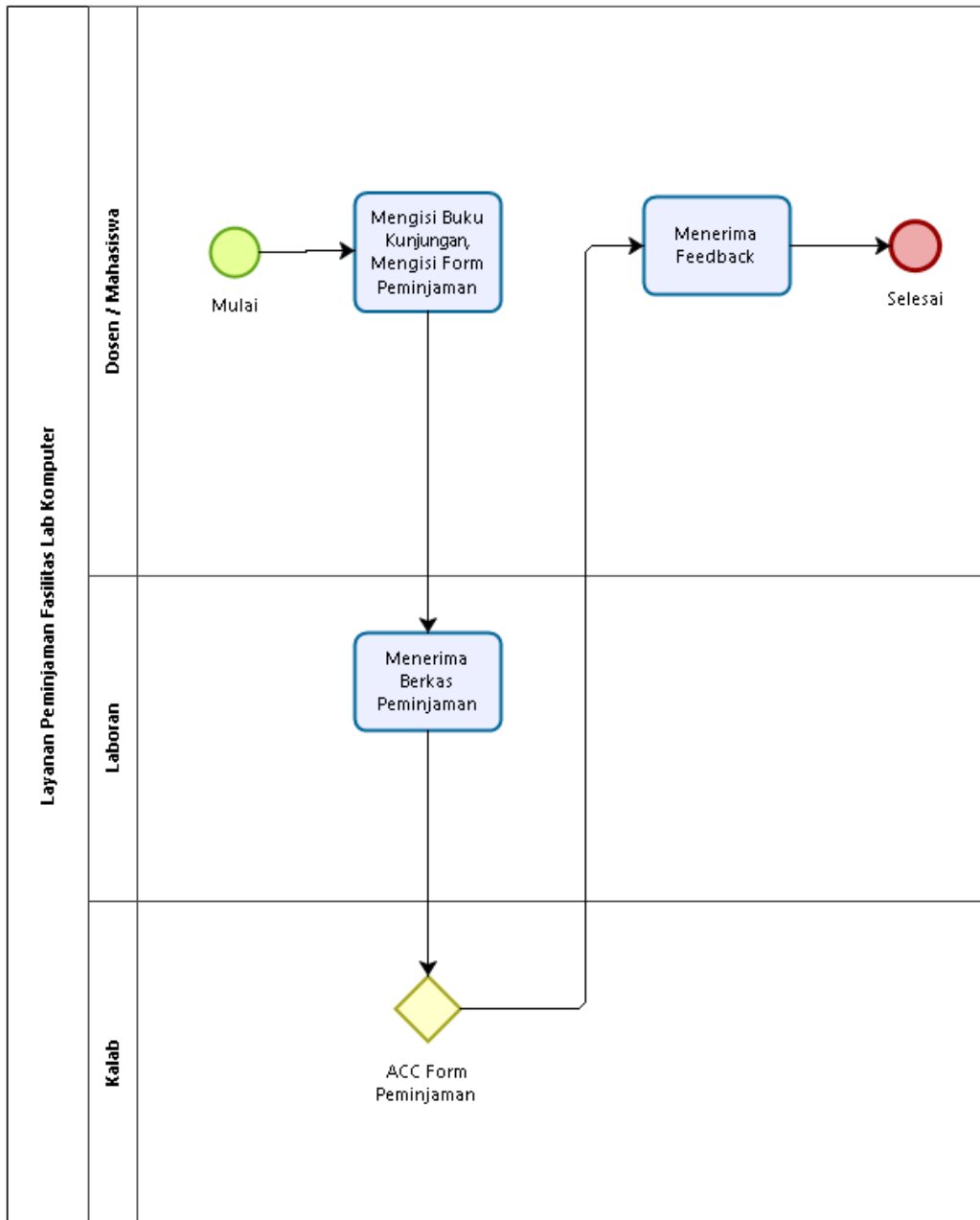

Level 3 Layanan Evaluasi Kurikulum

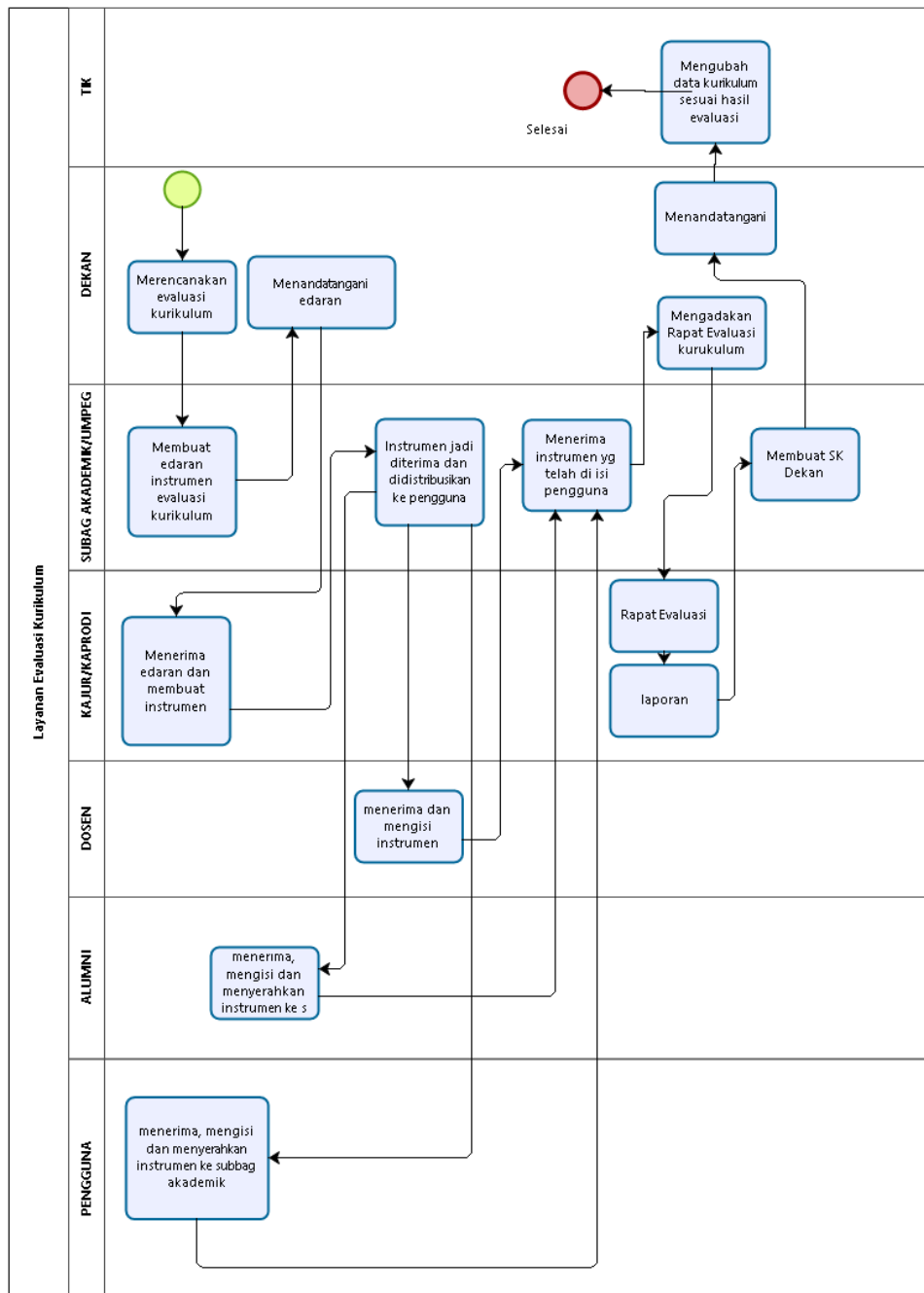

Level 3 Layanan Pelaksanaan Ujian Akhir Semester

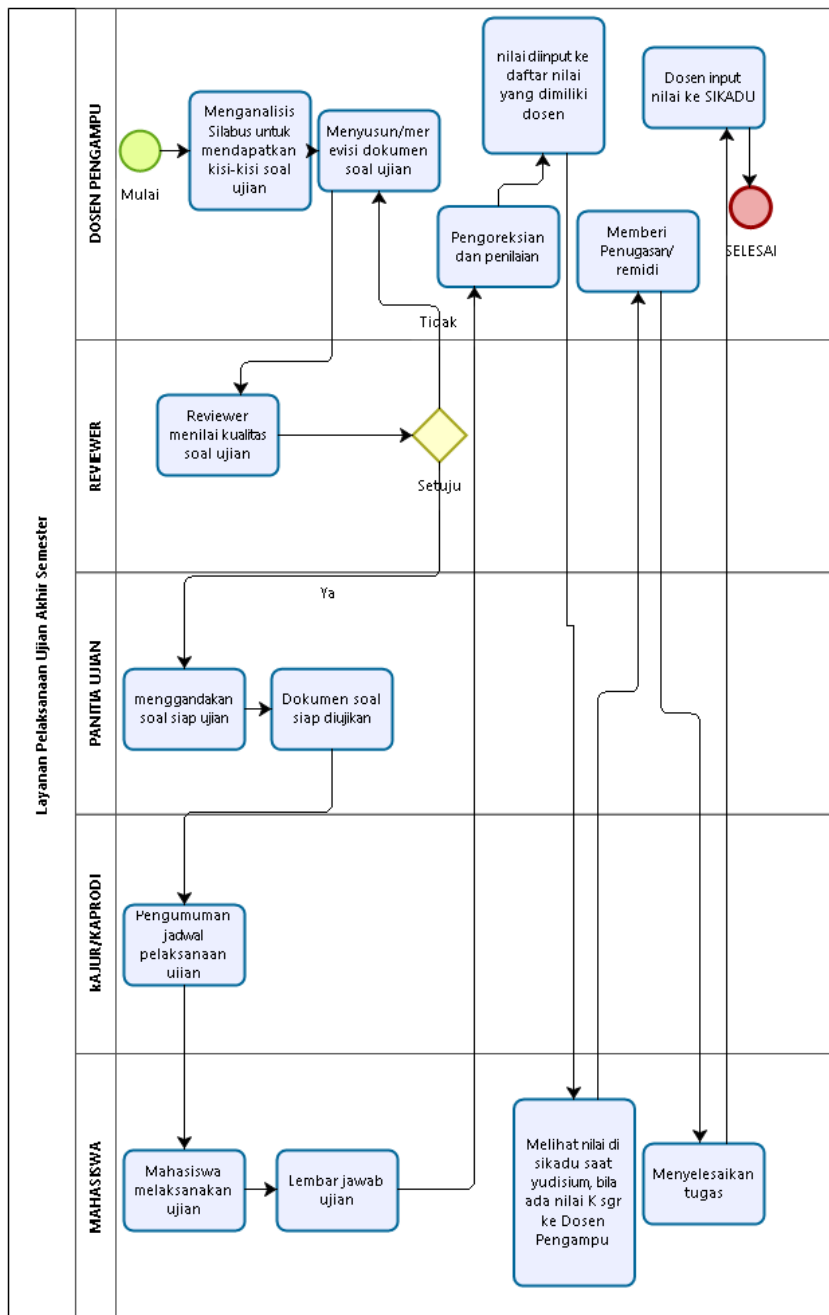

Level 3 Layanan Pelaksanaan Kuliah Kerja Lapangan (KKL)

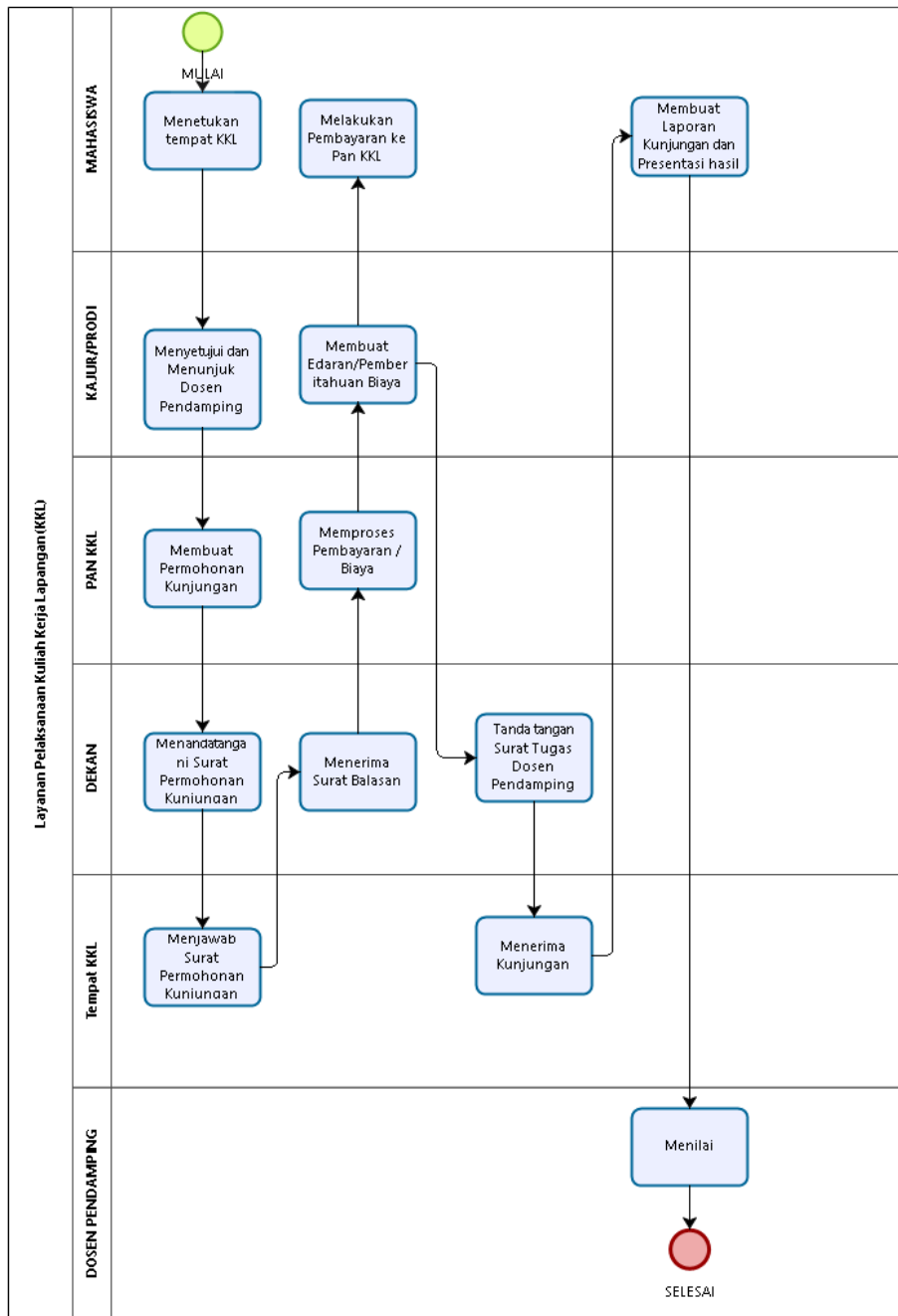

Level 3 Layanan Pelaksanaan Praktik Kerja Lapangan (PKL)

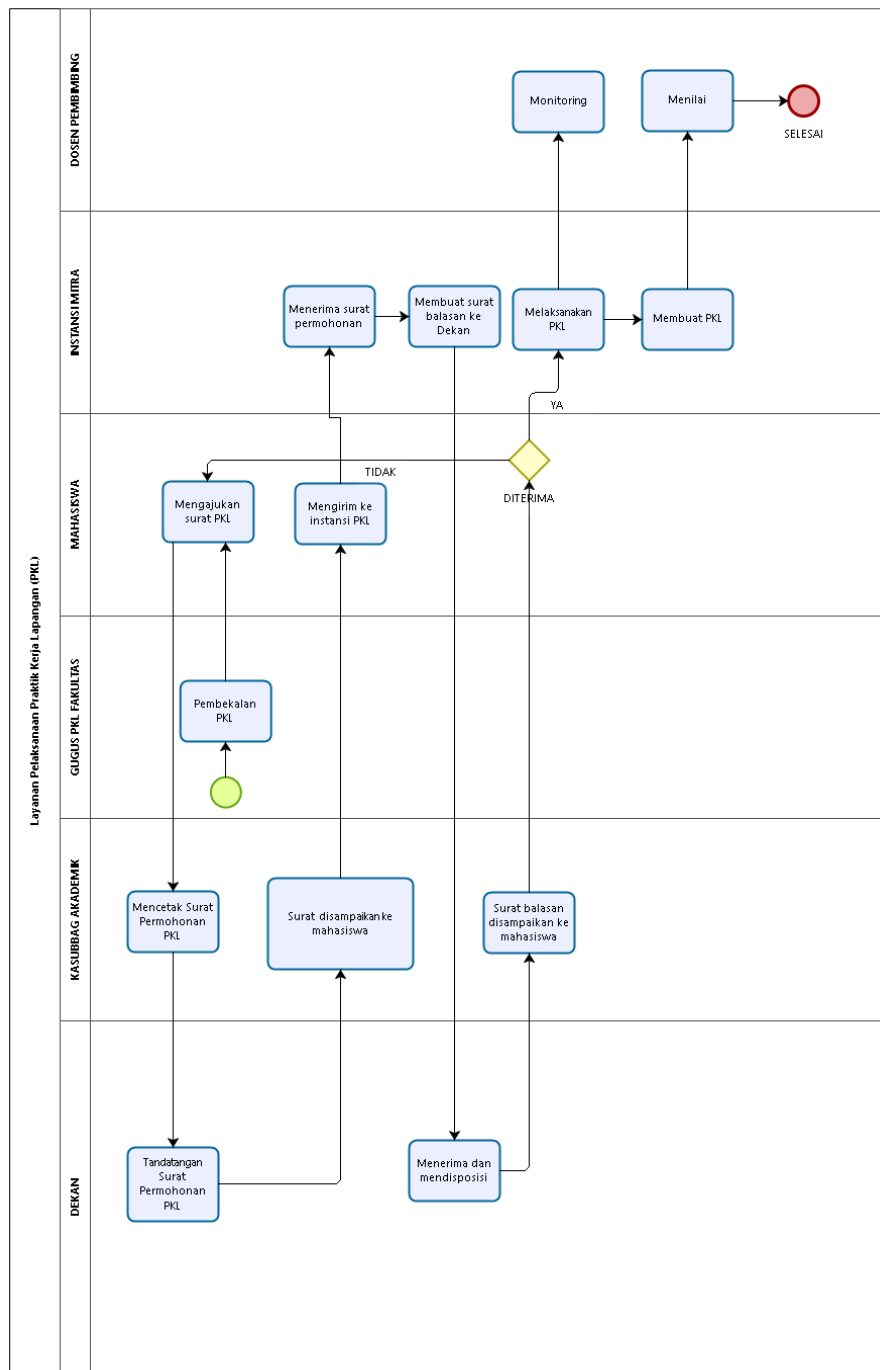

Level 3 Layanan UNNES LANTIP

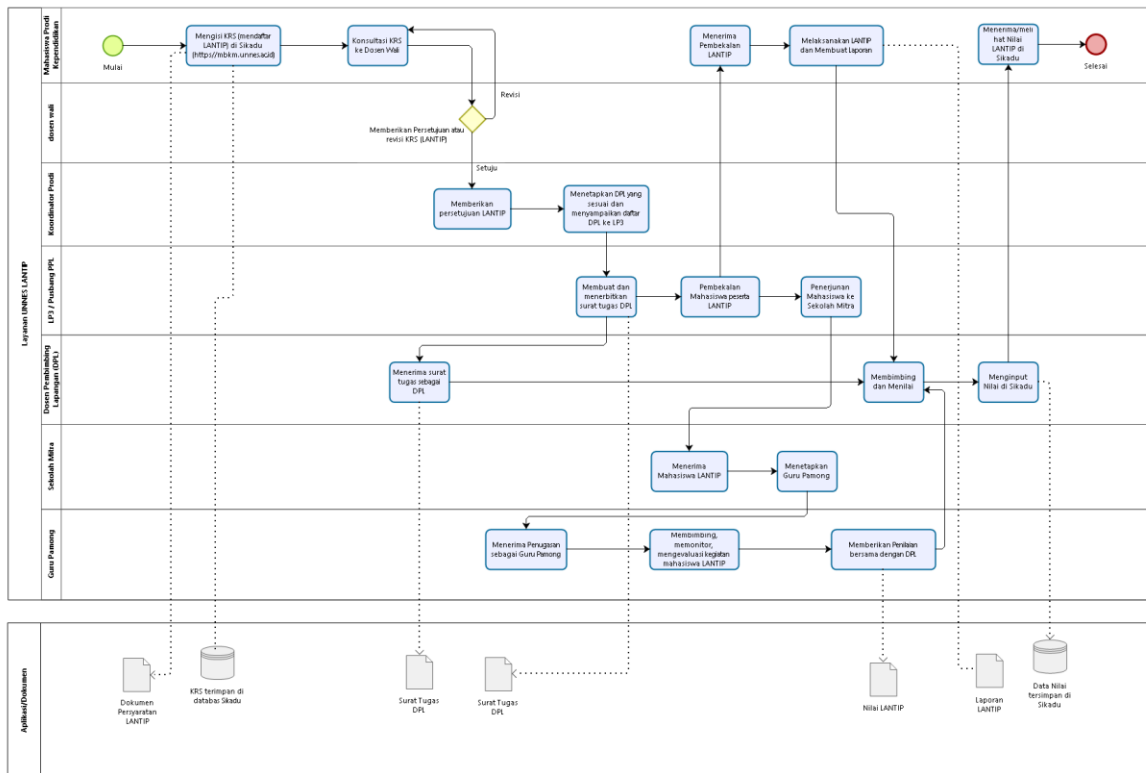

Level 3 Layanan UNNES PRIGEL

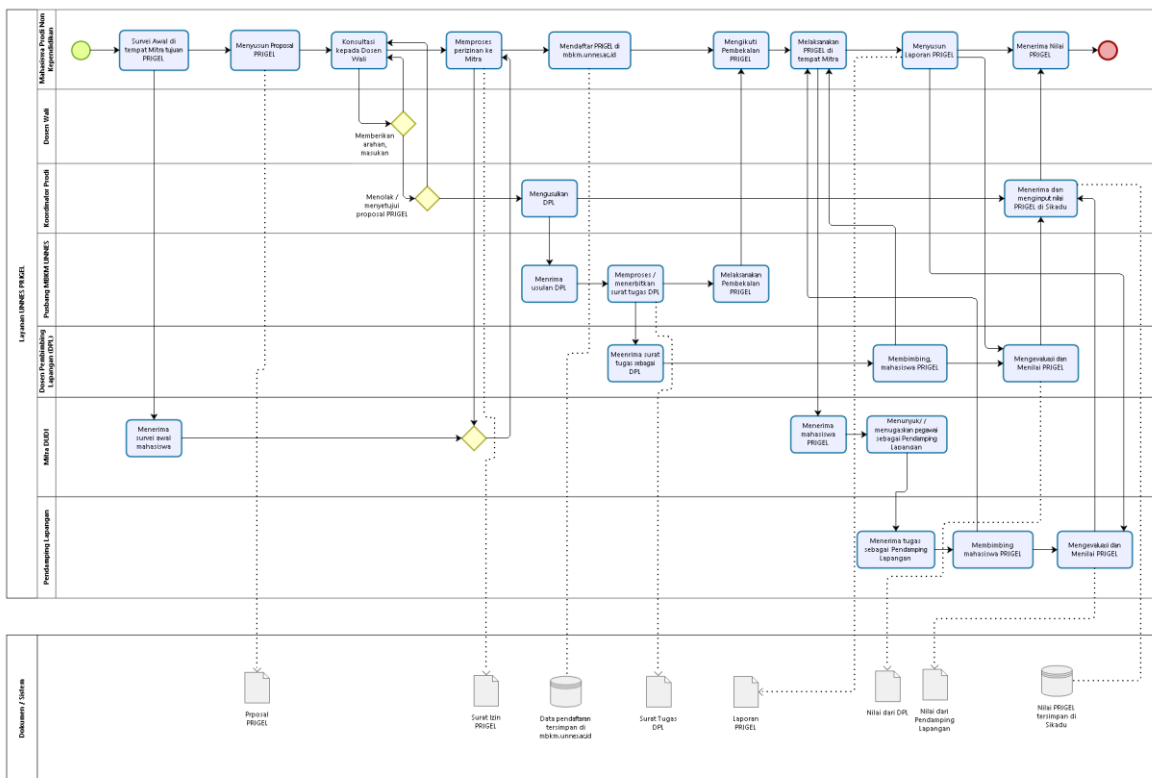

Level 3 Layanan UNNES GIAT

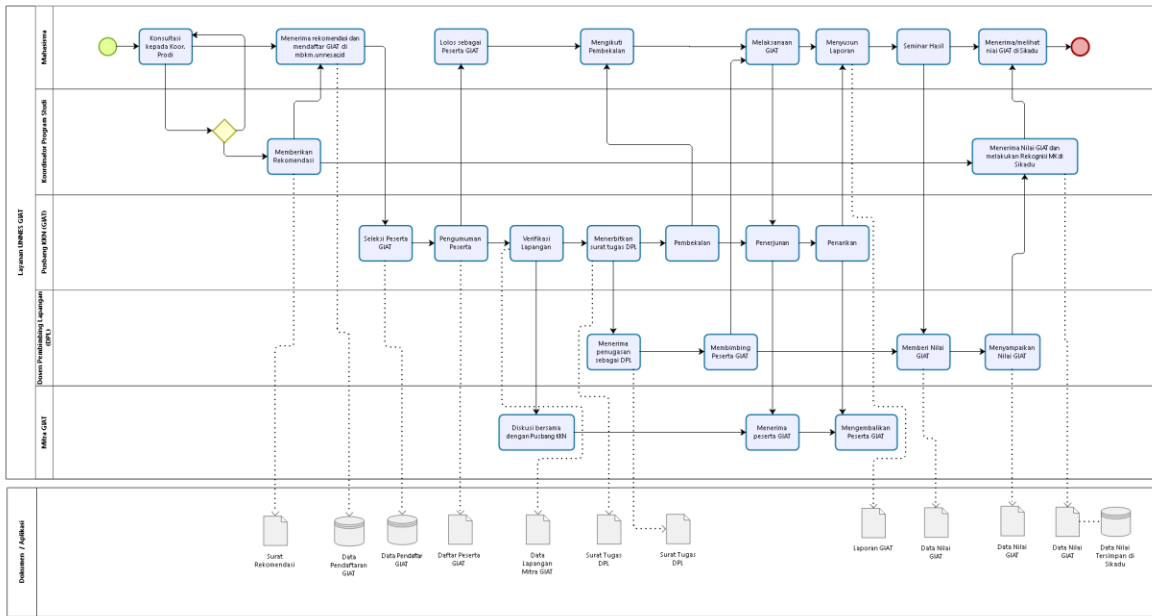

Level 3 Layanan Peminjaman Fasilitas Laboratorium

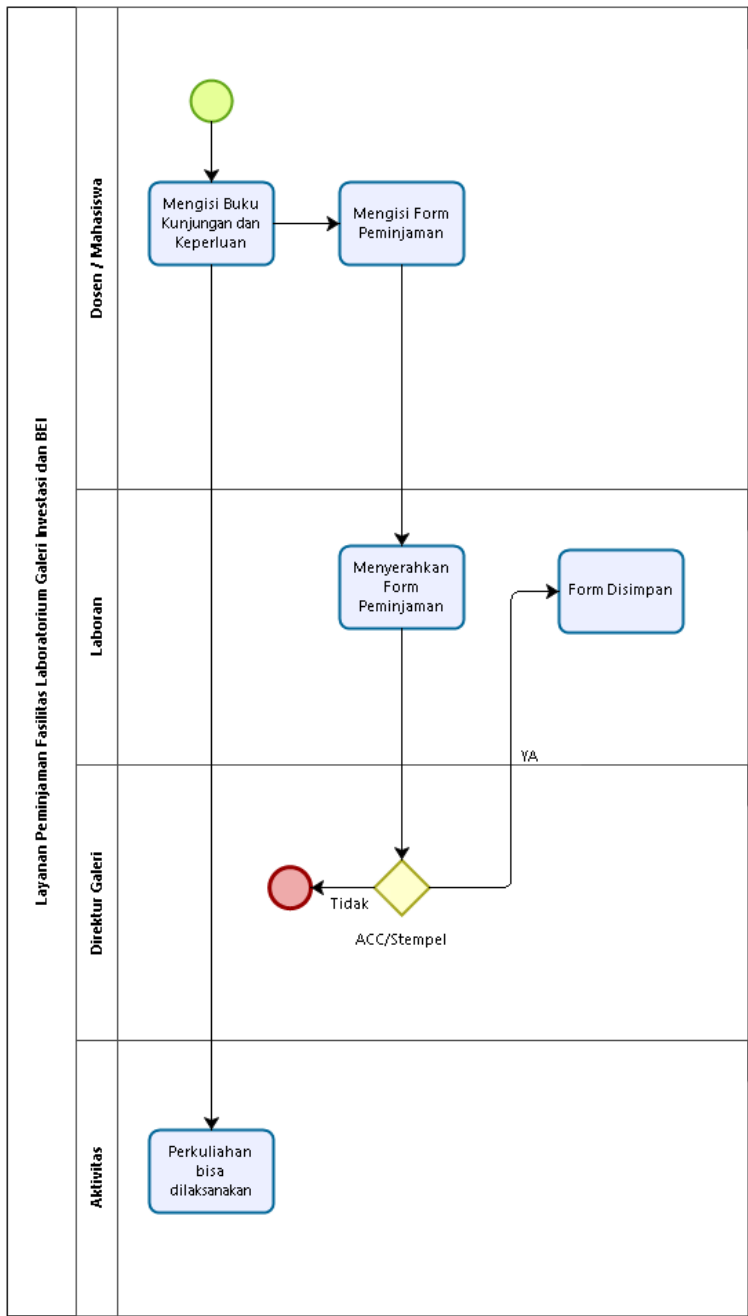

Level 3 Layanan Pelatihan Fakultas / Pascasarjana

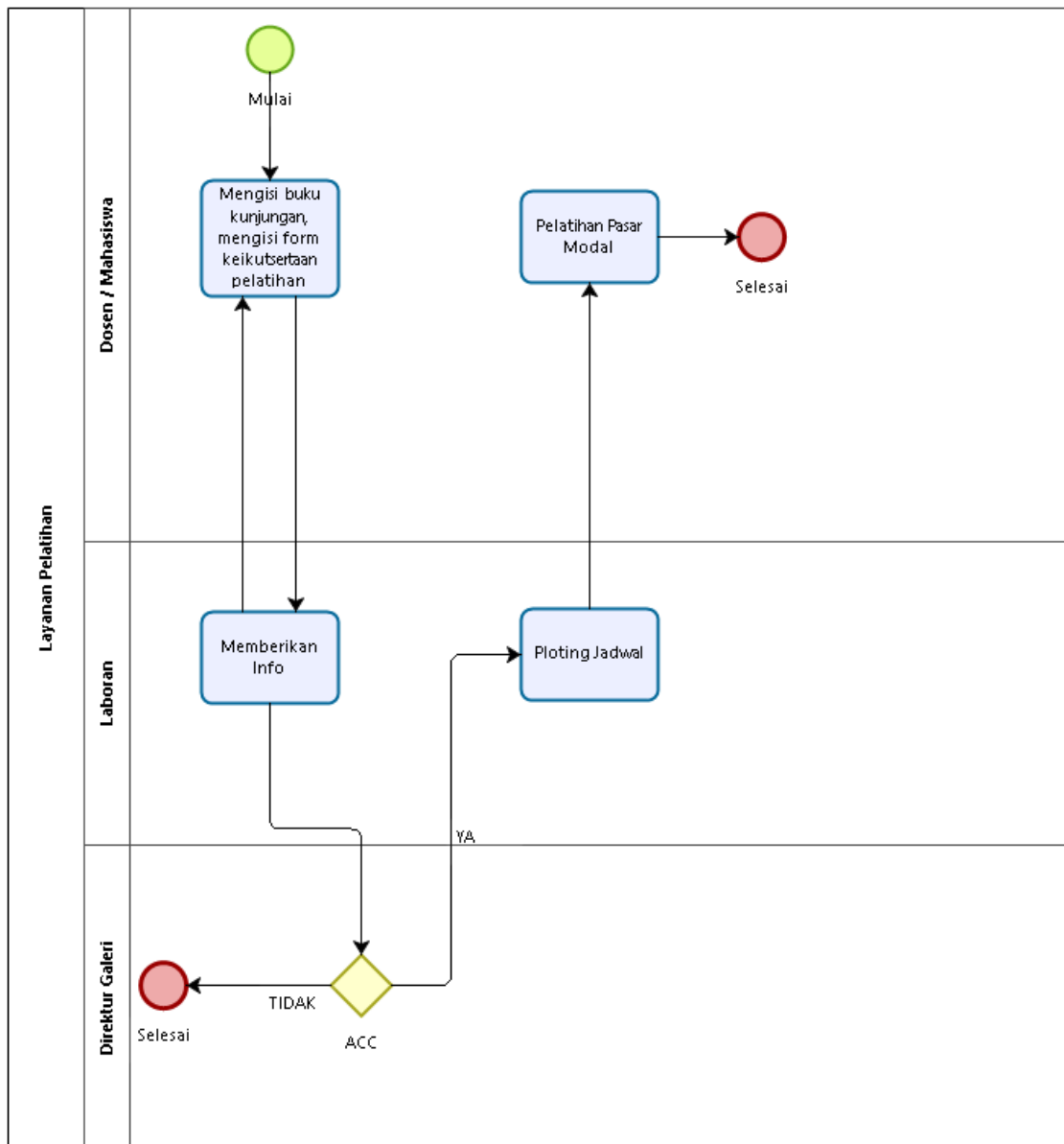

Level 3 Layanan Akses Data

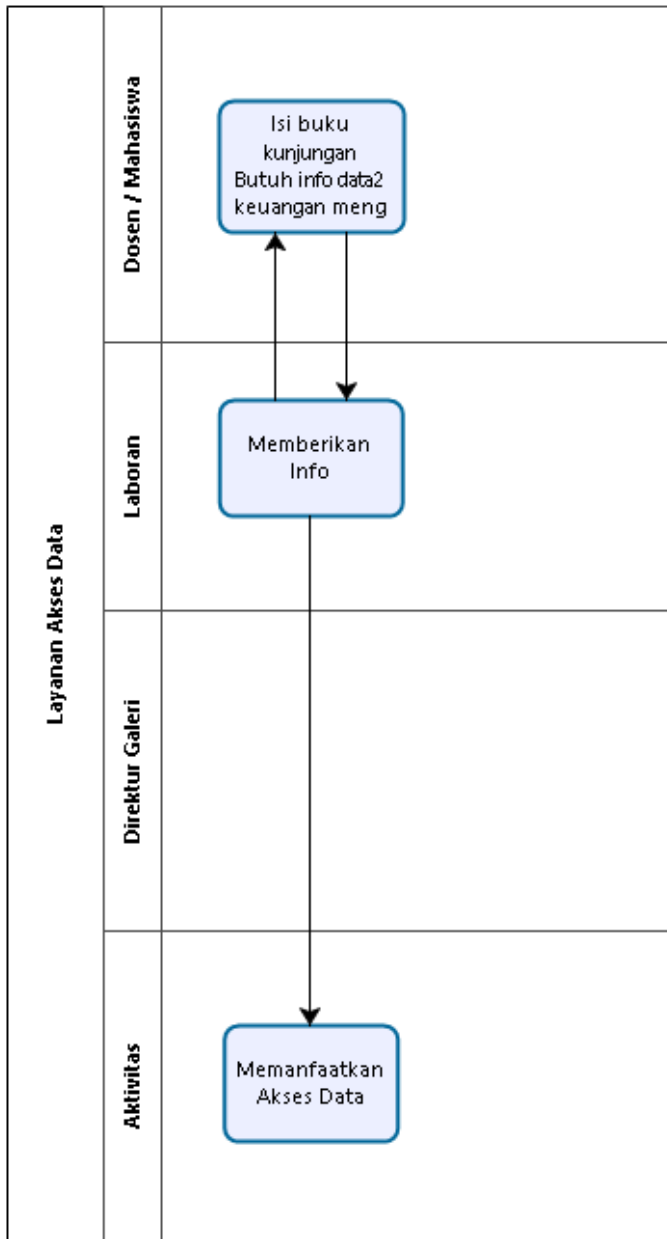

Level 3 Layanan Surat Aktif Kuliah, dll

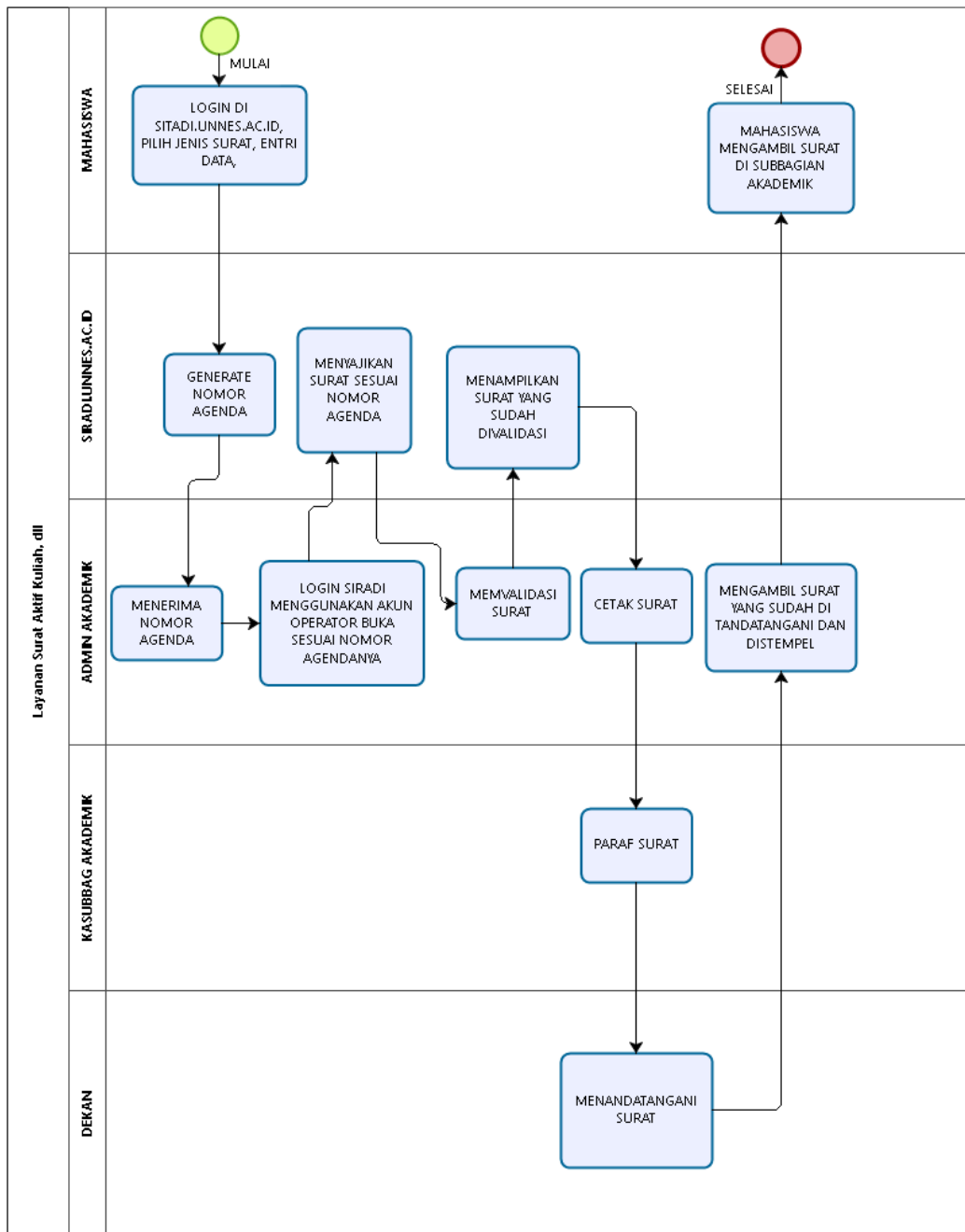

Level 2 Layanan Keuangan Fakultas / Pascasarjana

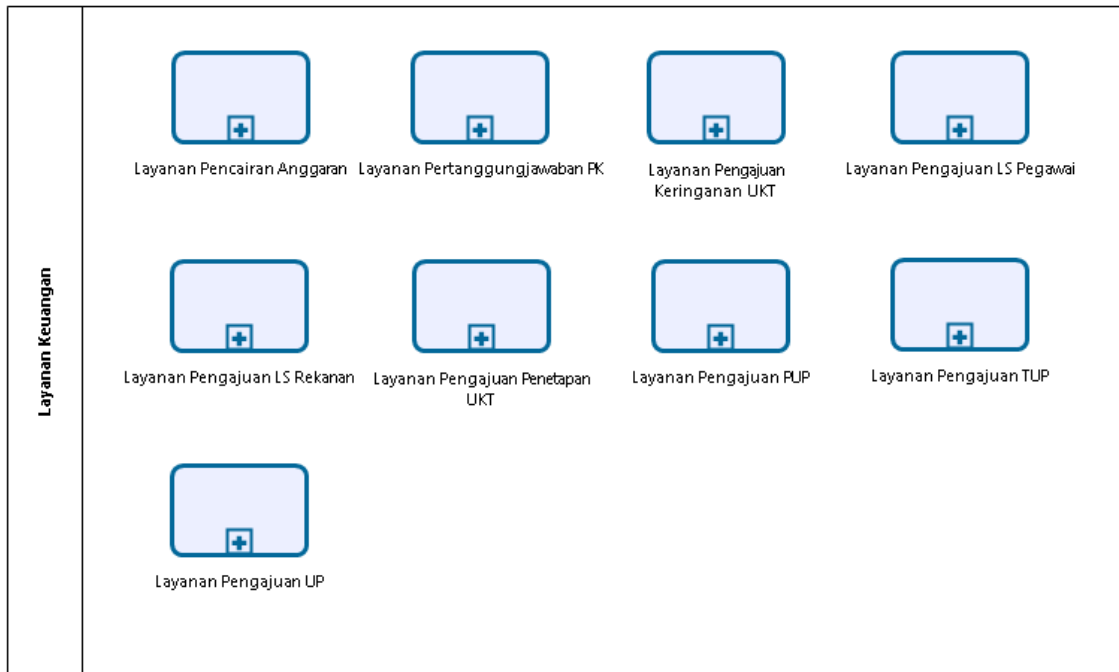

Level 3 Layanan Pencairan Anggaran

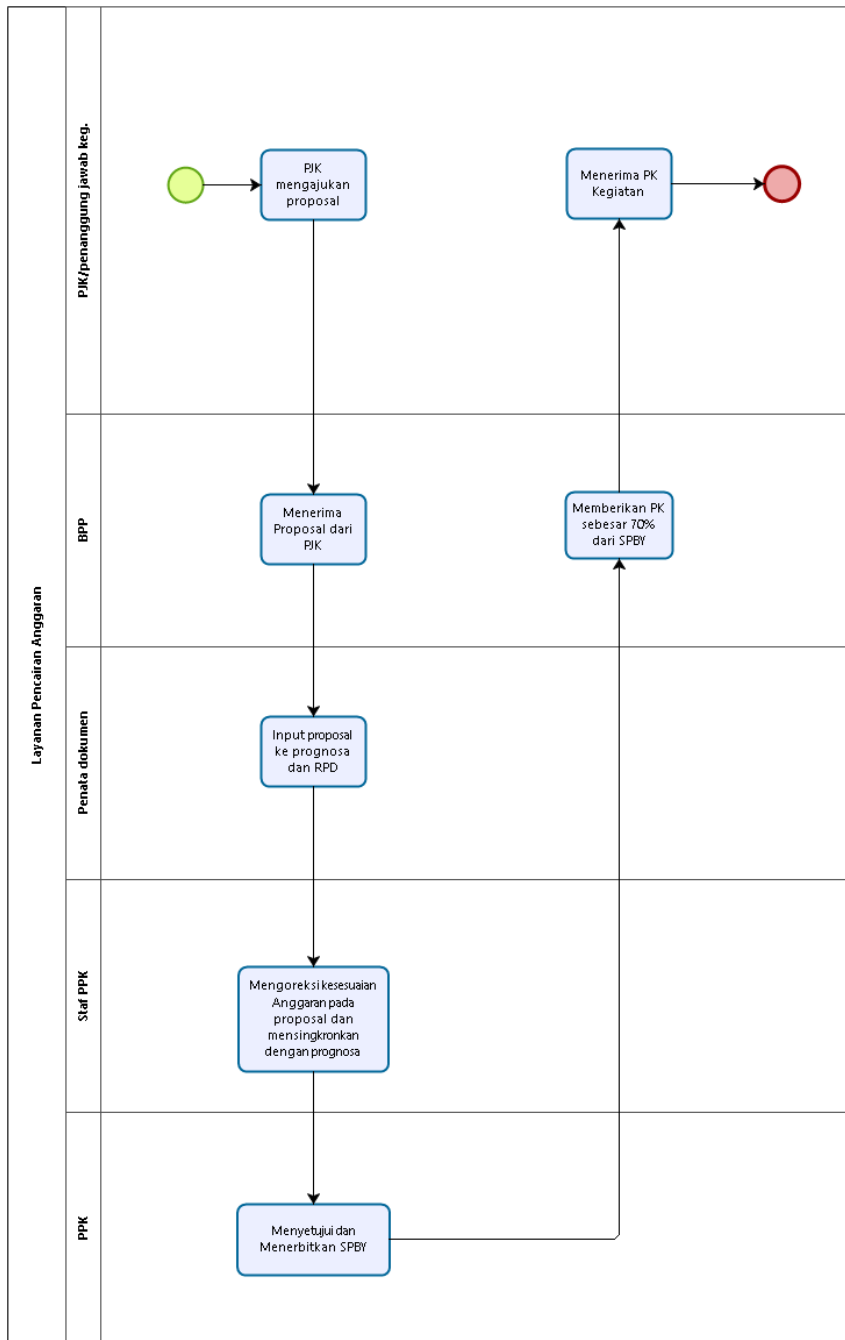

Level 3 Layanan Pertanggungjawaban PK

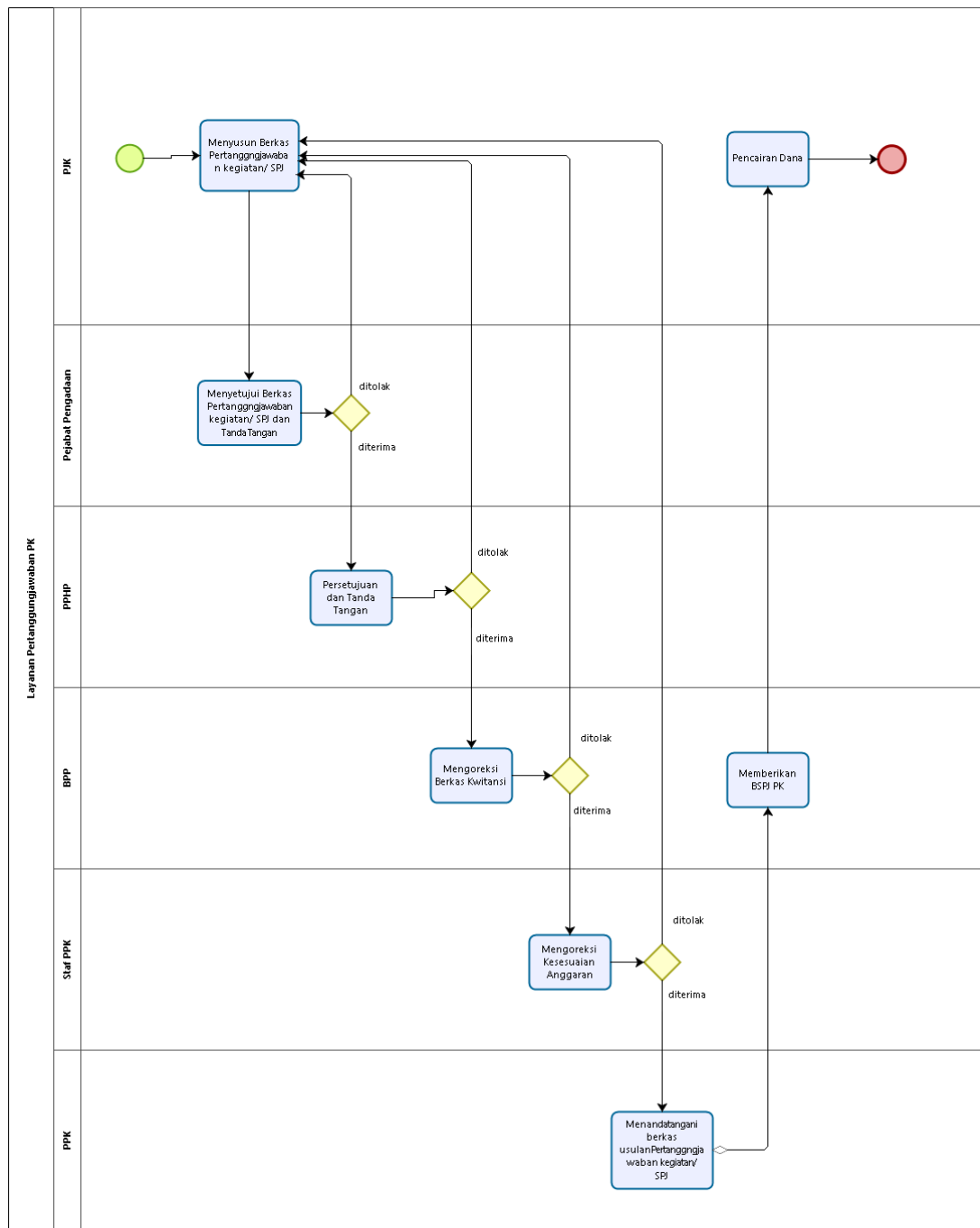

Level 3 Layanan Pengajuan Keringanan UKT

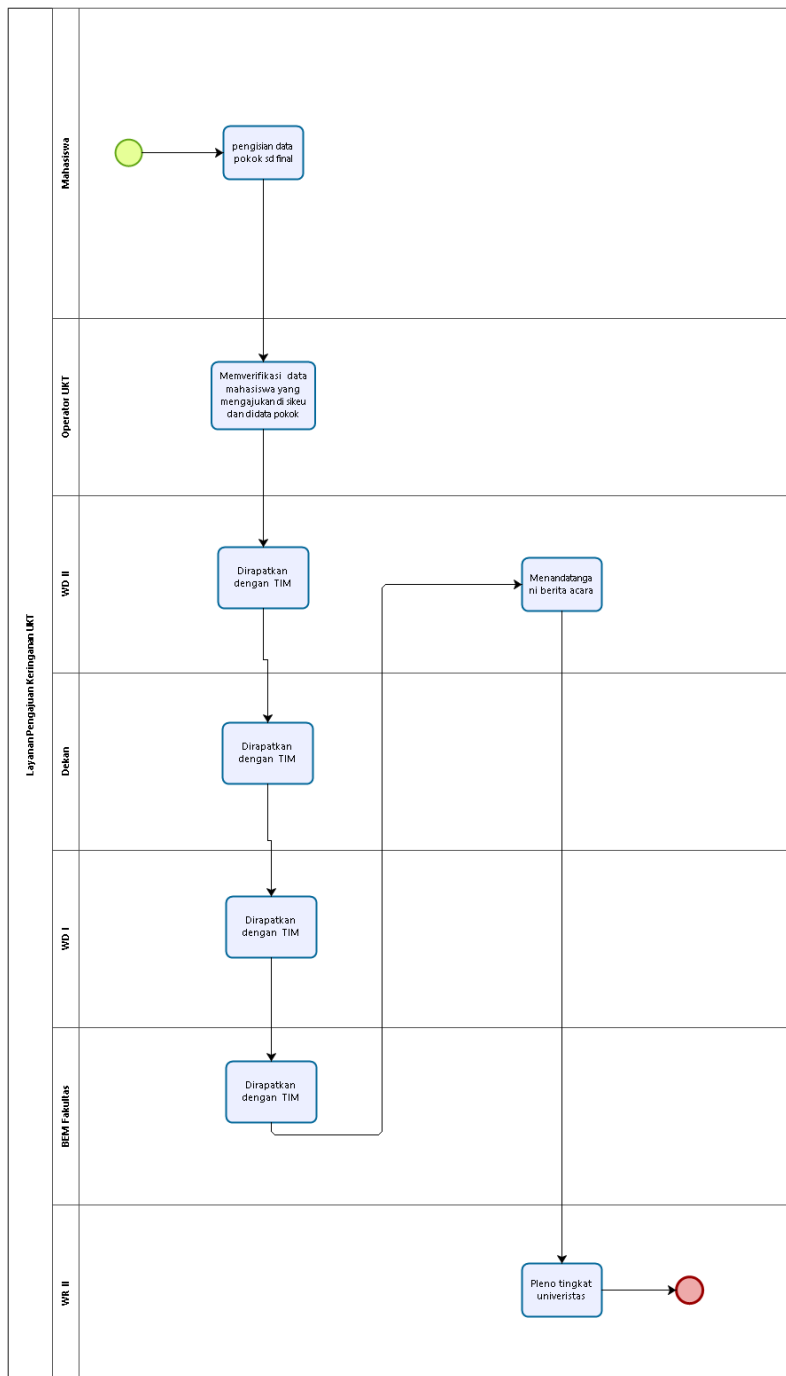

Powered by
bizagi
Modeler

Level 3 Layanan Pengajuan LS Pegawai

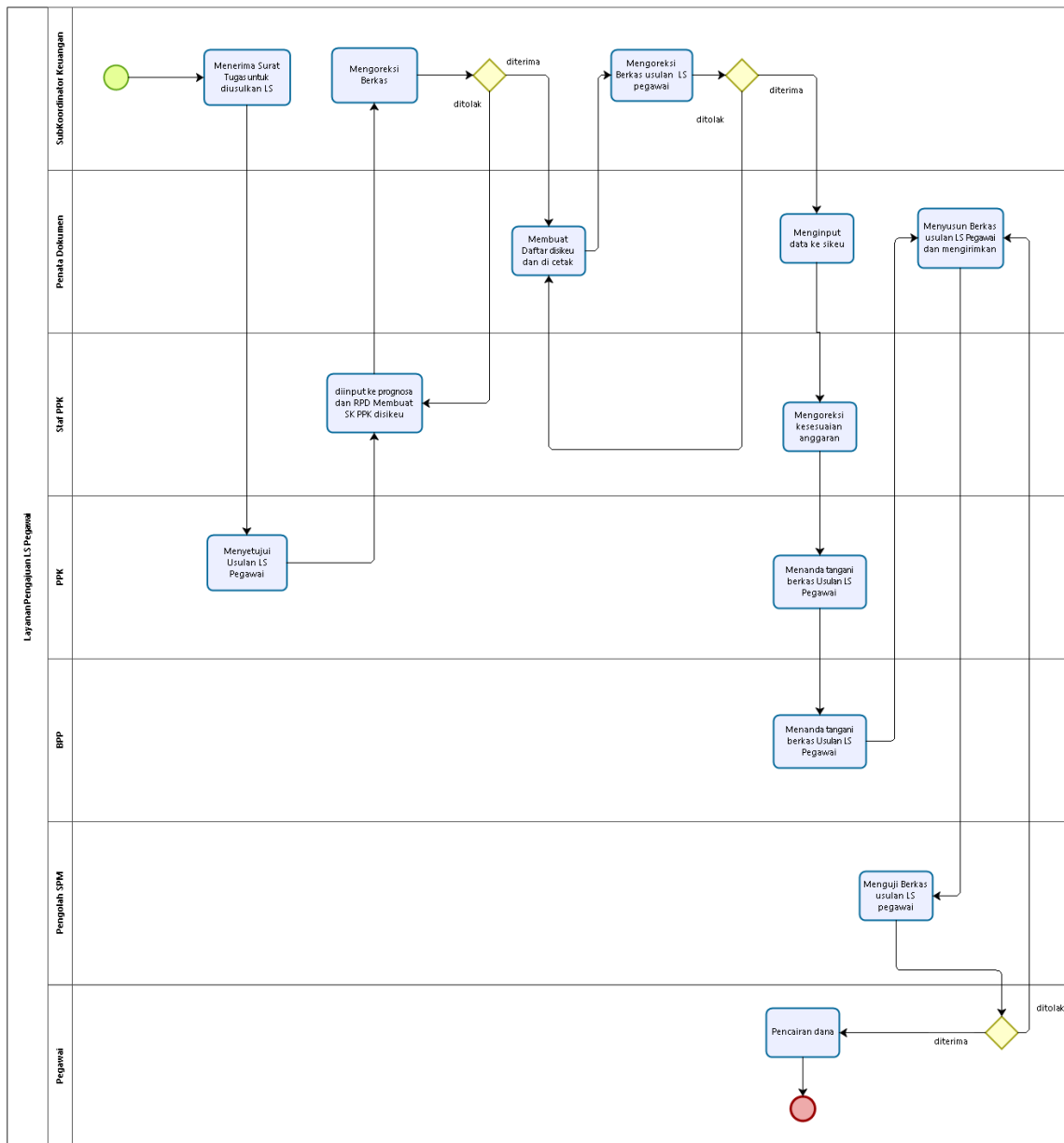

Level 3 Layanan Pengajuan LS Rekanan

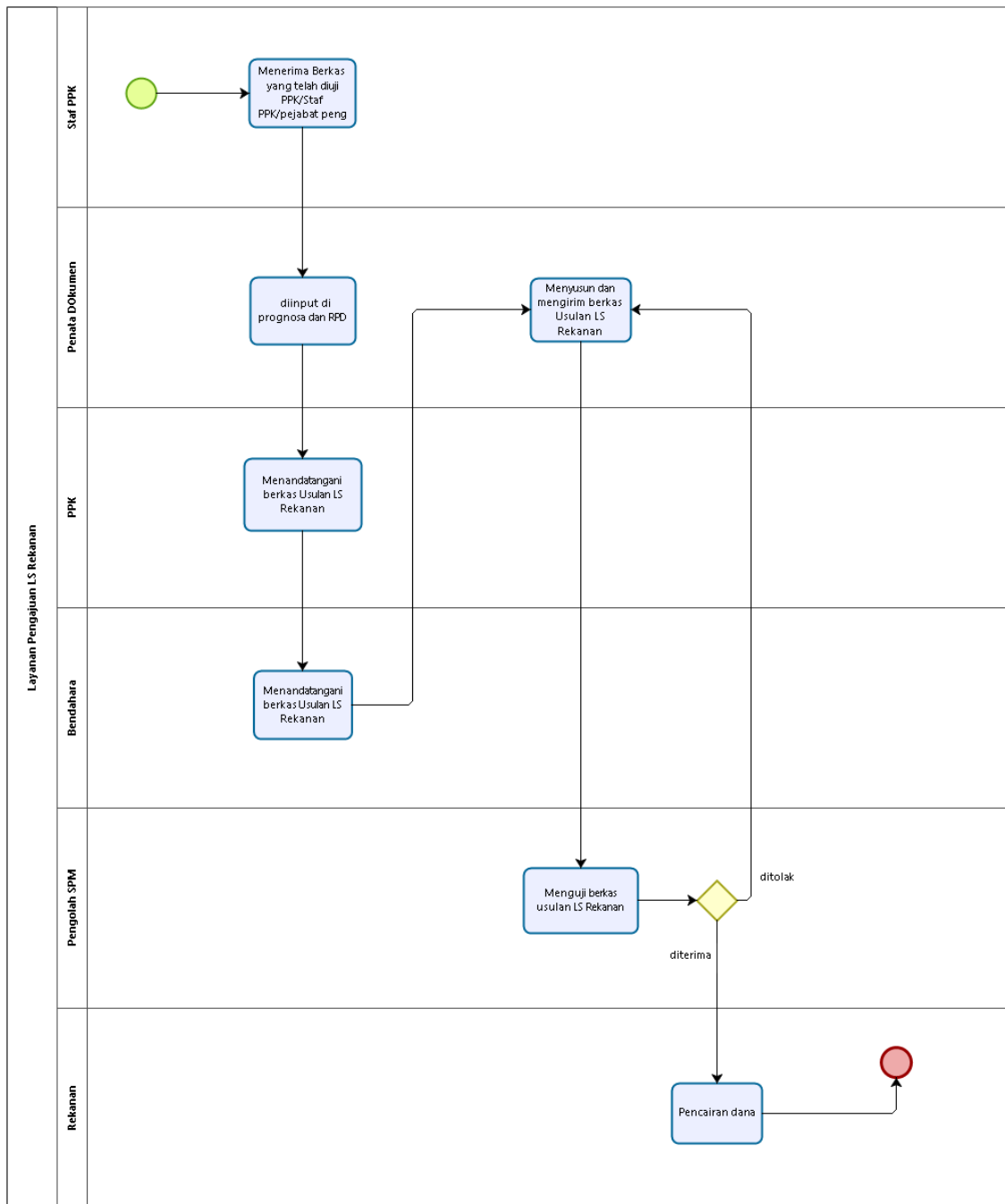

Level 3 Layanan Pengajuan Penetapan UKT

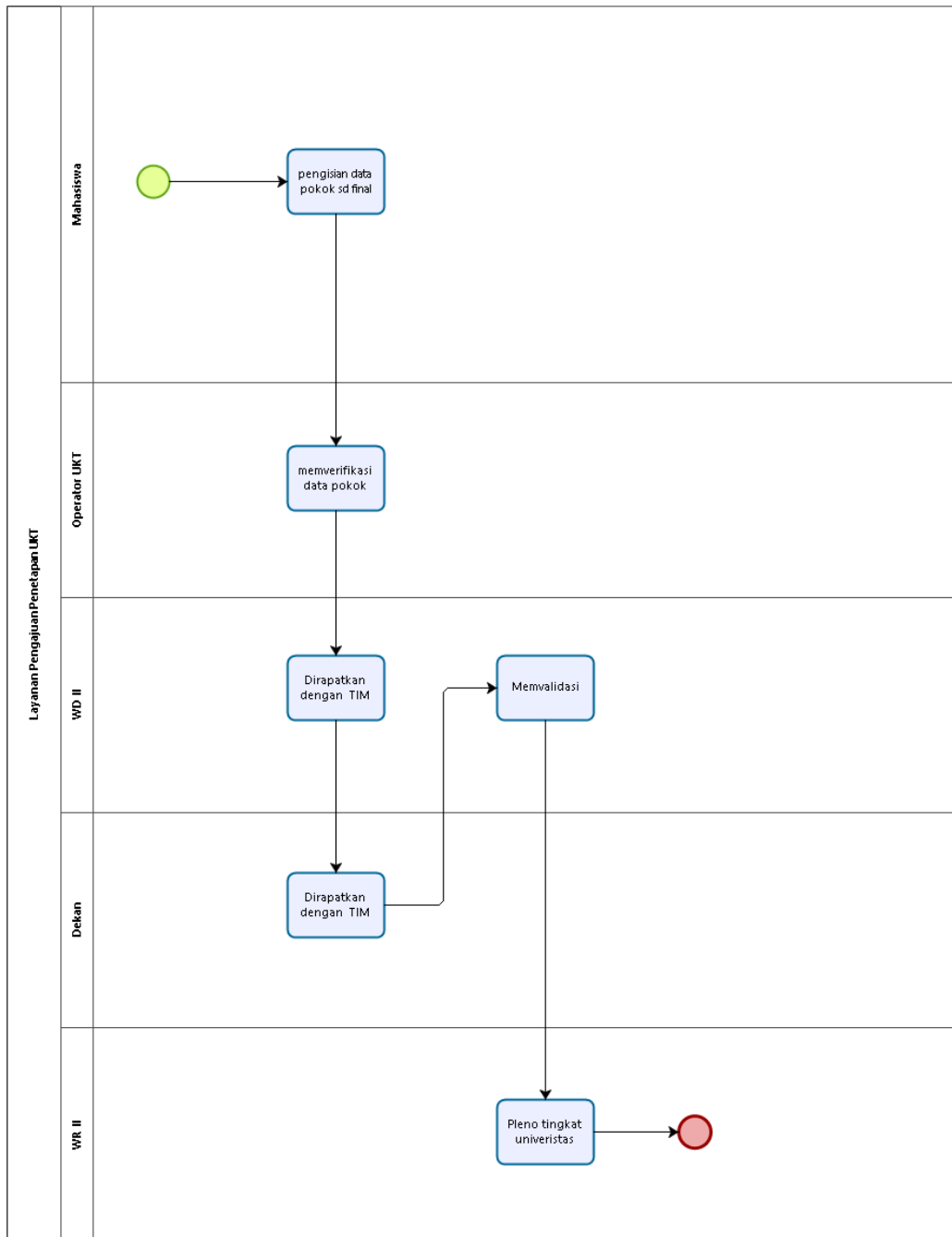

Level 3 Layanan Pengajuan PUP

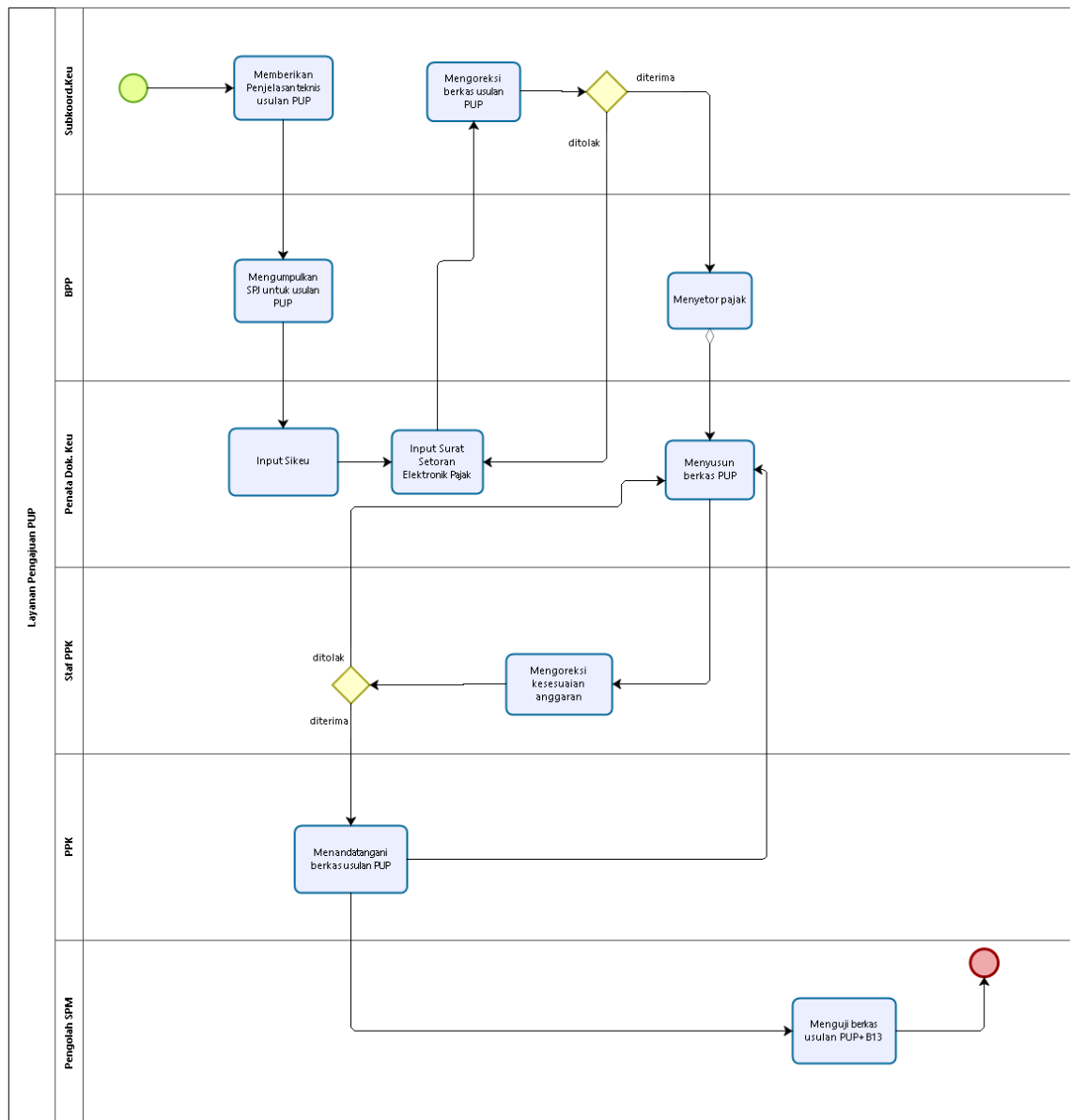

Level 3 Layanan Pengajuan TUP

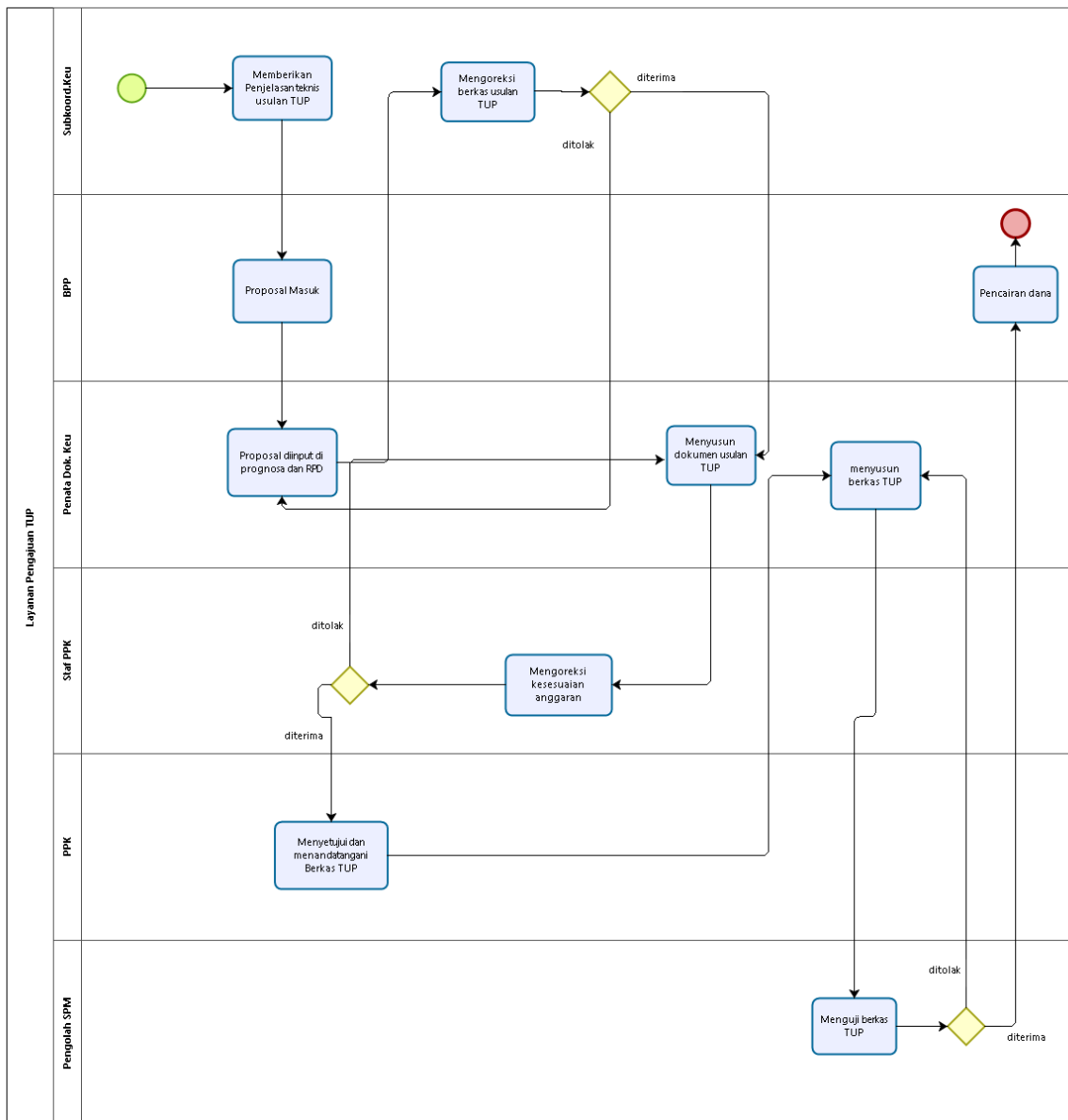

Level 2 Layanan Akuntansi Fakultas / Pascasarjana

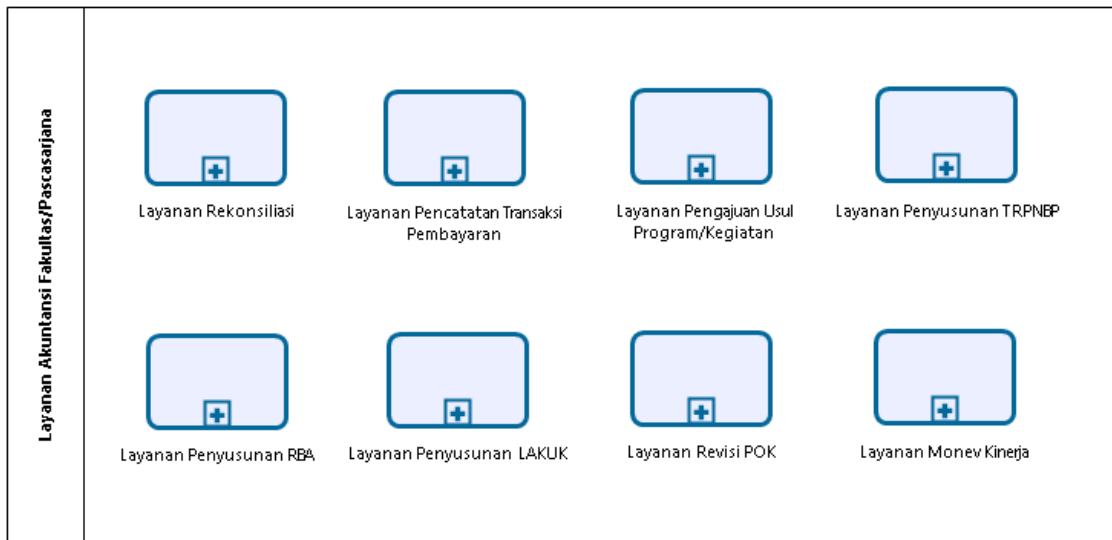

Powered by
bizagi
Modeler

Level 3 Layanan Rekonsiliasi

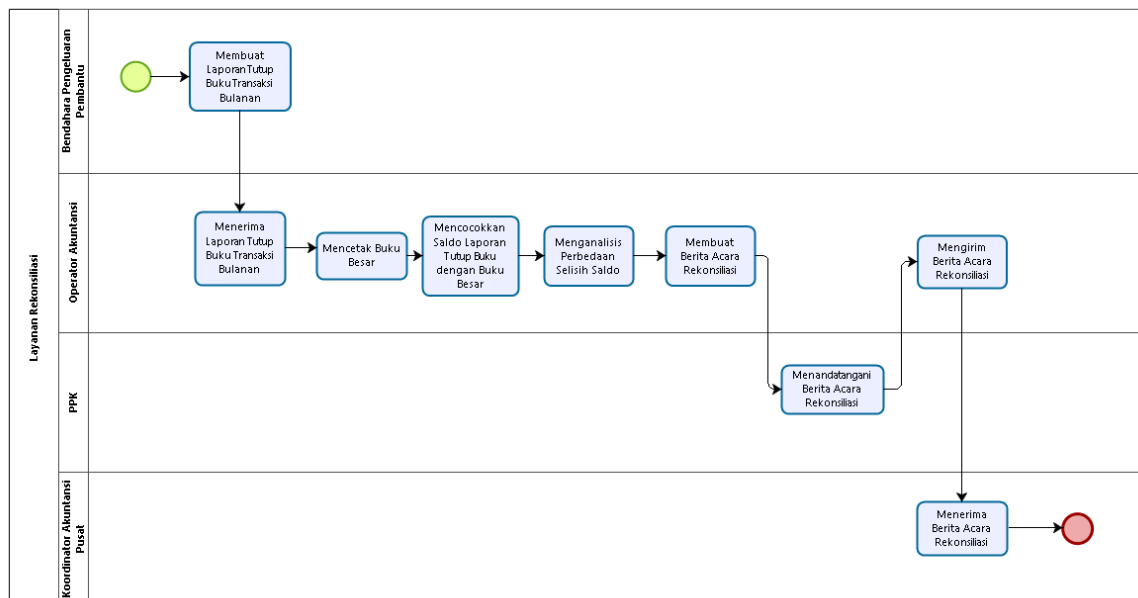

Powered by
bizagi
Modeler

Level 3 Layanan Pencatatan Transaksi Pembayaran

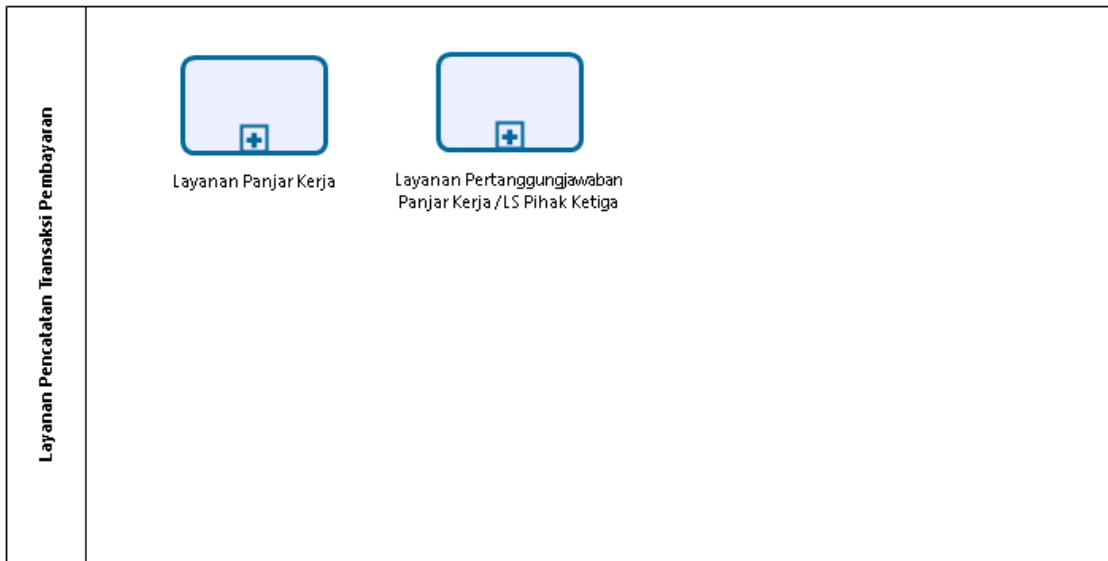

Level 4 Layanan Panjar Kerja

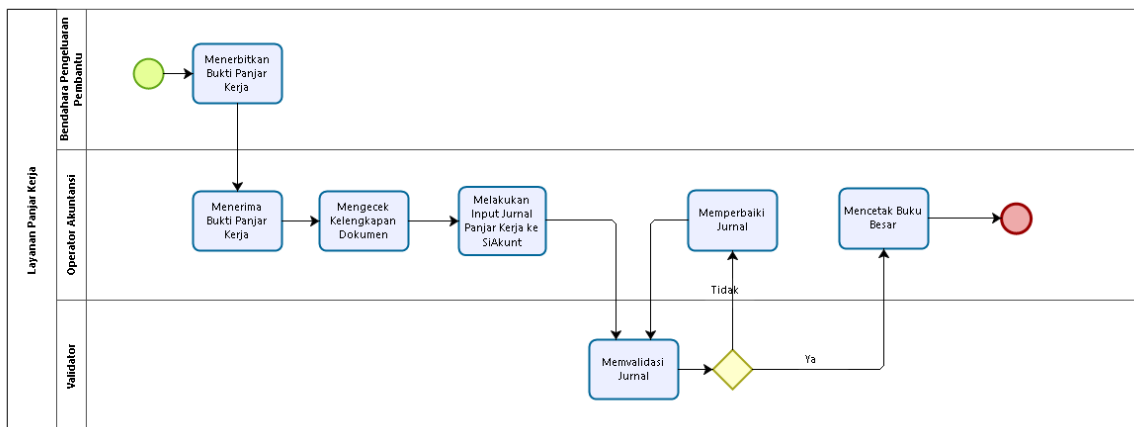

Level 4 Layanan Pertanggungjawaban Panjar Kerja / LS Pihak Ketiga

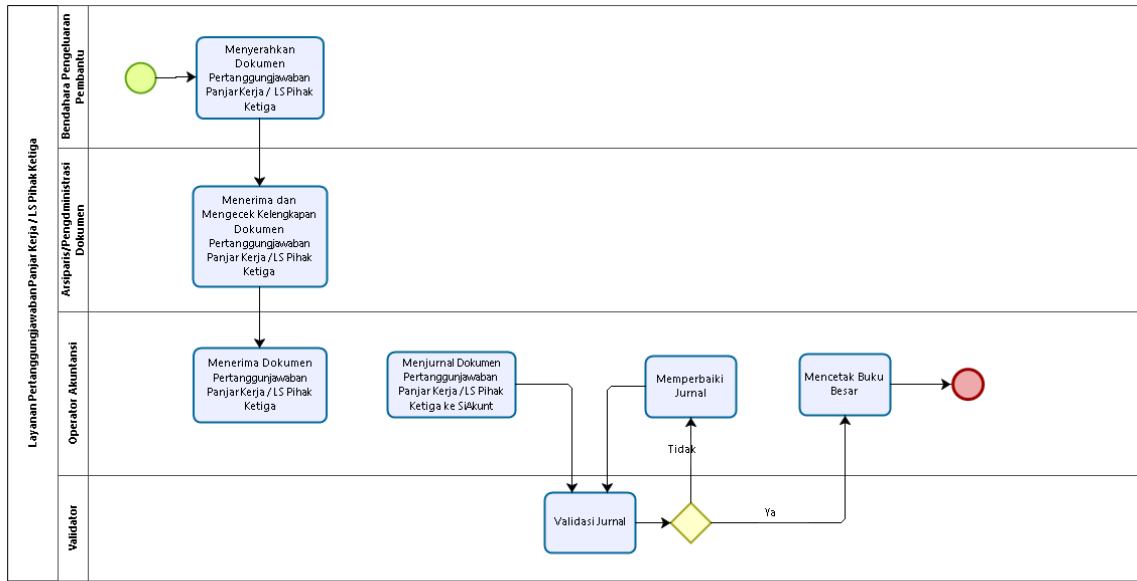

Level 3 Layanan Pengajuan Usul Program / Kegiatan

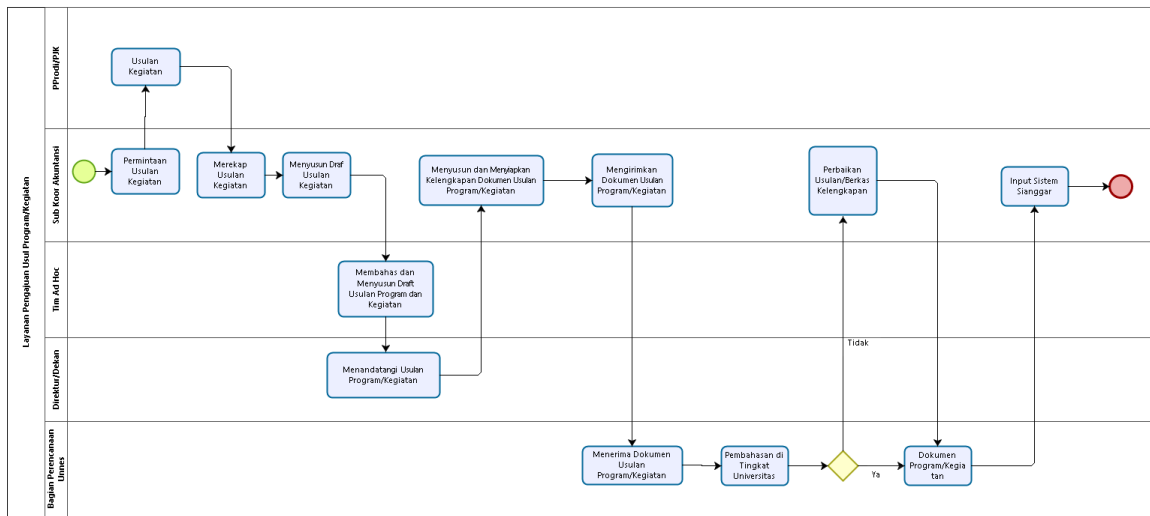

Level 3 Layanan Penyusunan TRPNBP

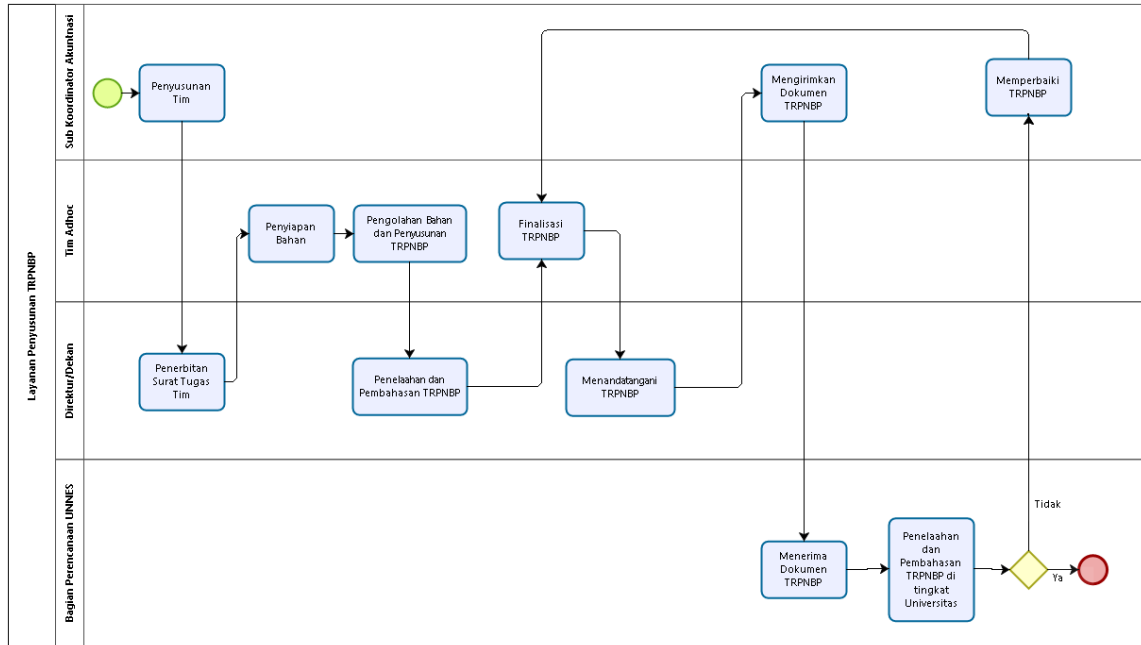

Powered by bizagi Modeler

Level 3 Layanan Penyusunan RBA

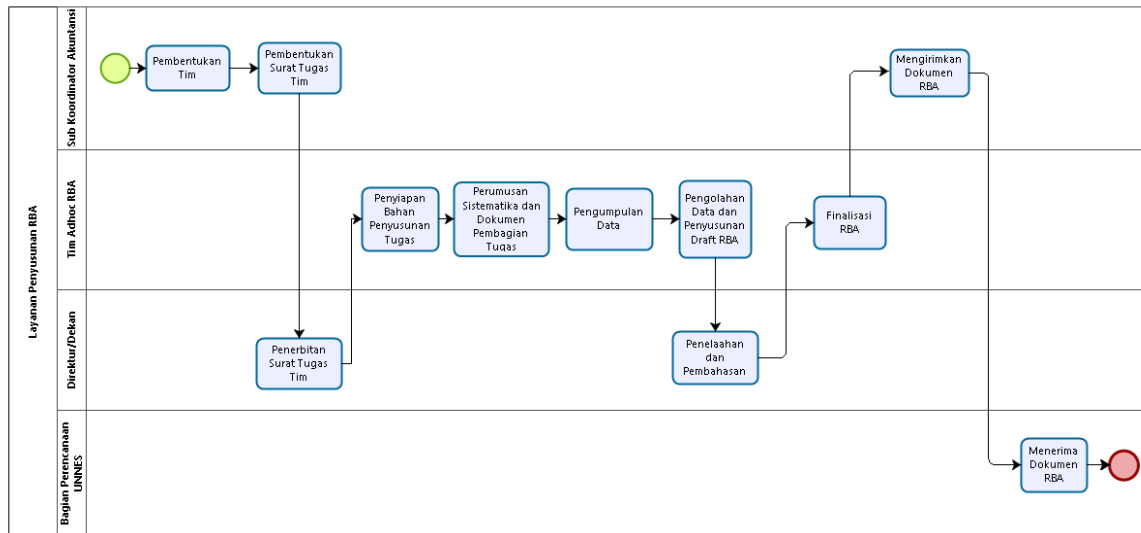

Powered by bizagi Modeler

Level 3 Layanan Penyusunan LAKUK

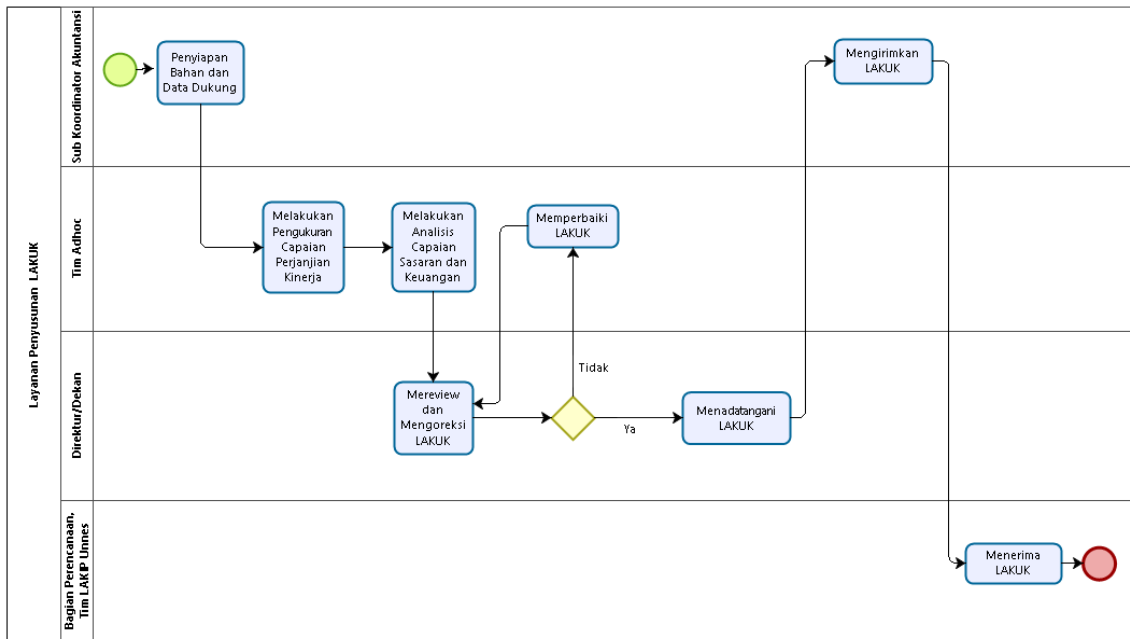

Level 3 Layanan Revisi POK

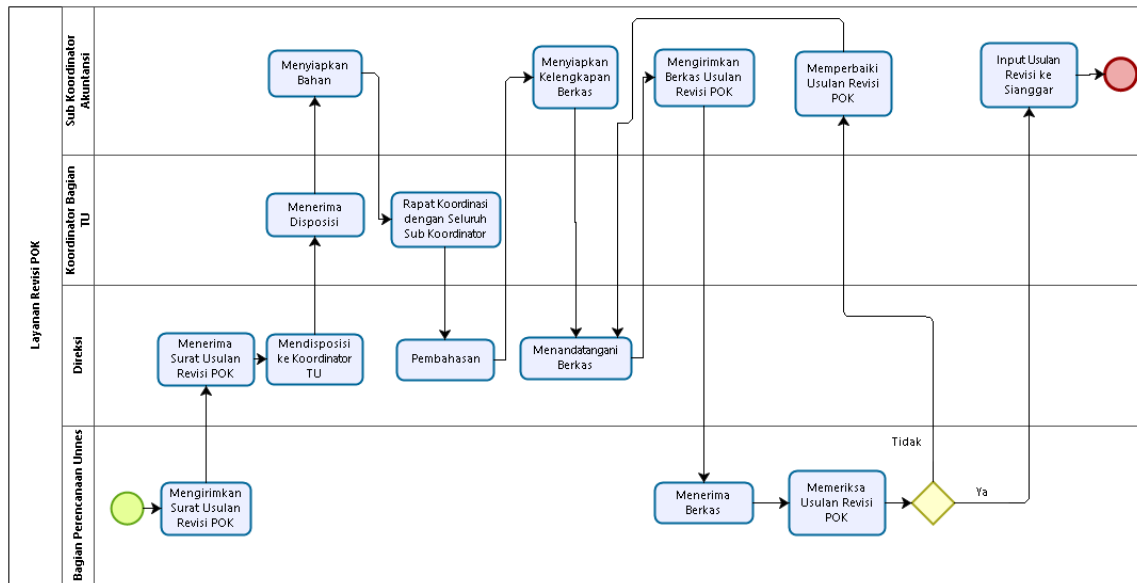

Powered by
bizagi
Modeler

Level 3 Layanan Monev Kinerja

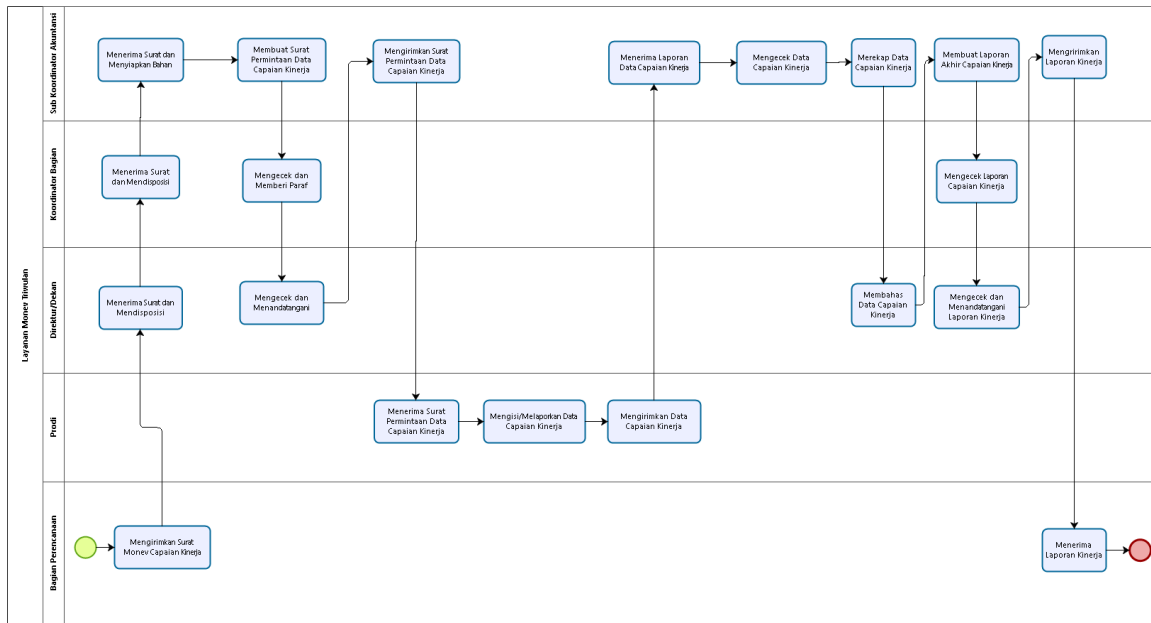

Level 2 Layanan Umum dan Kepegawaian

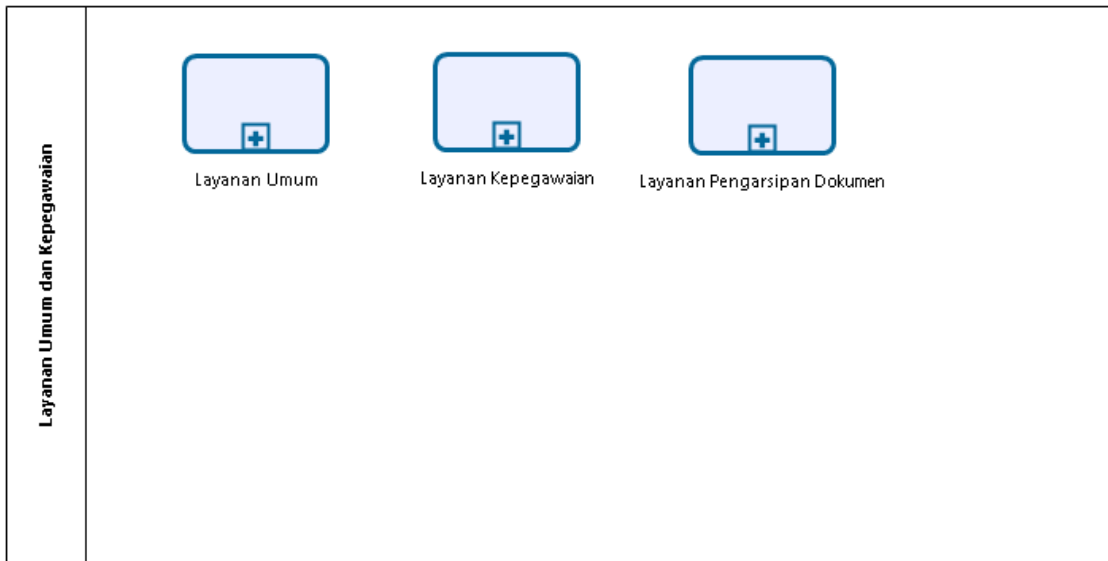

Powered by
bizagi
Modeler

Level 3 Layanan Umum

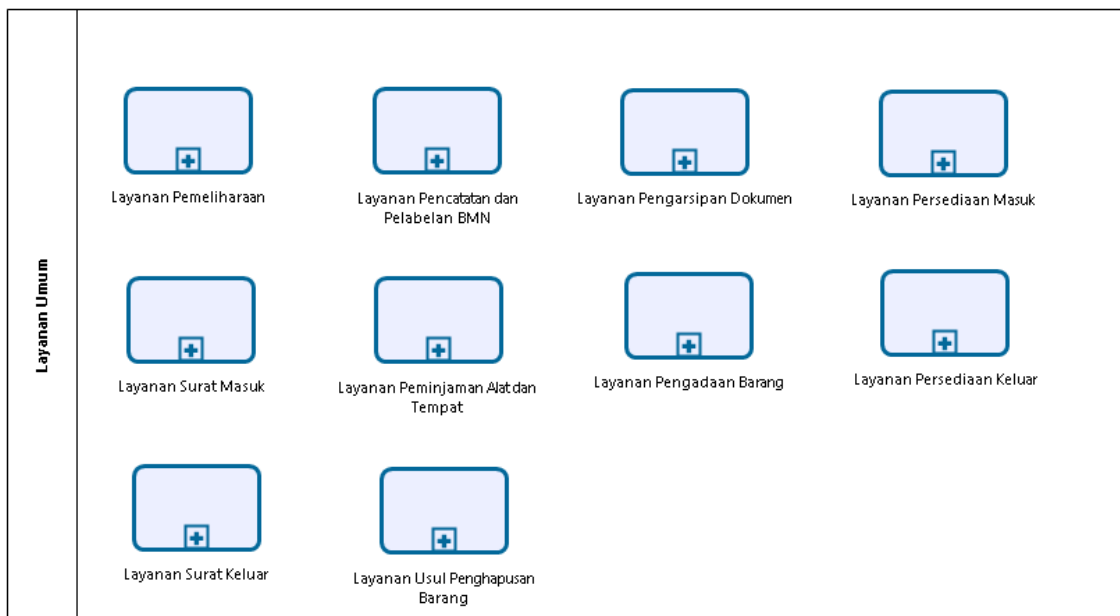

Powered by
bizagi
Modeler

Level 4 Layanan Pemeliharaan Fakultas / Pascasarjana

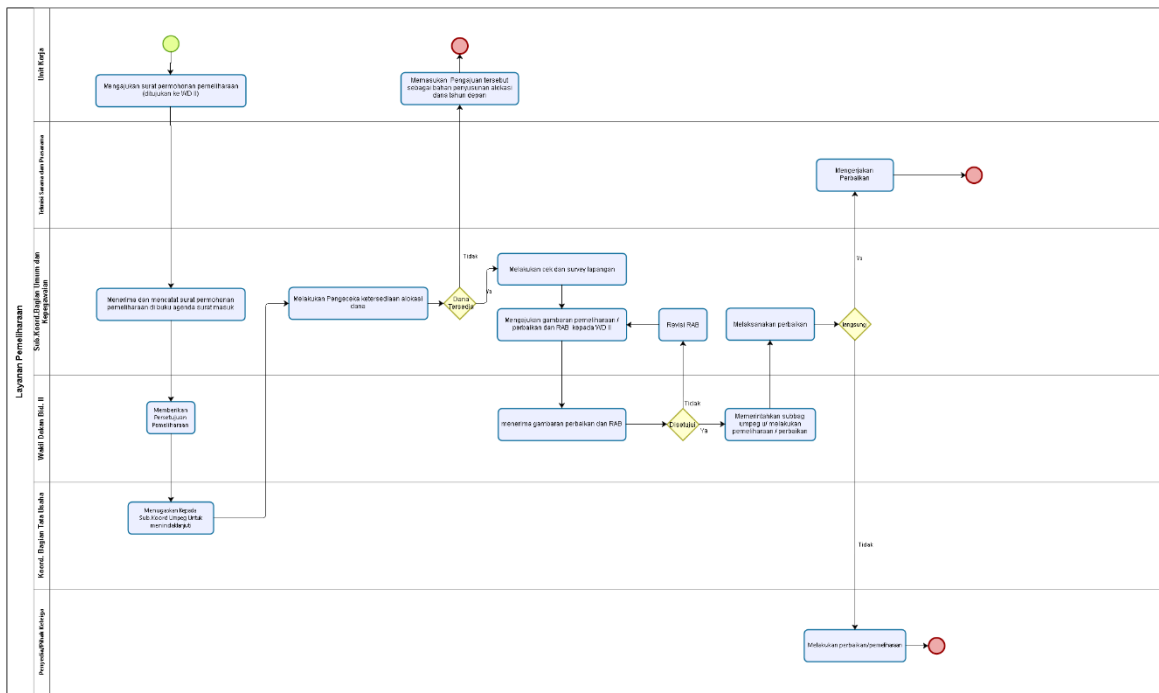

Level 4 Layanan Pencatatan dan Pelabelan BMN

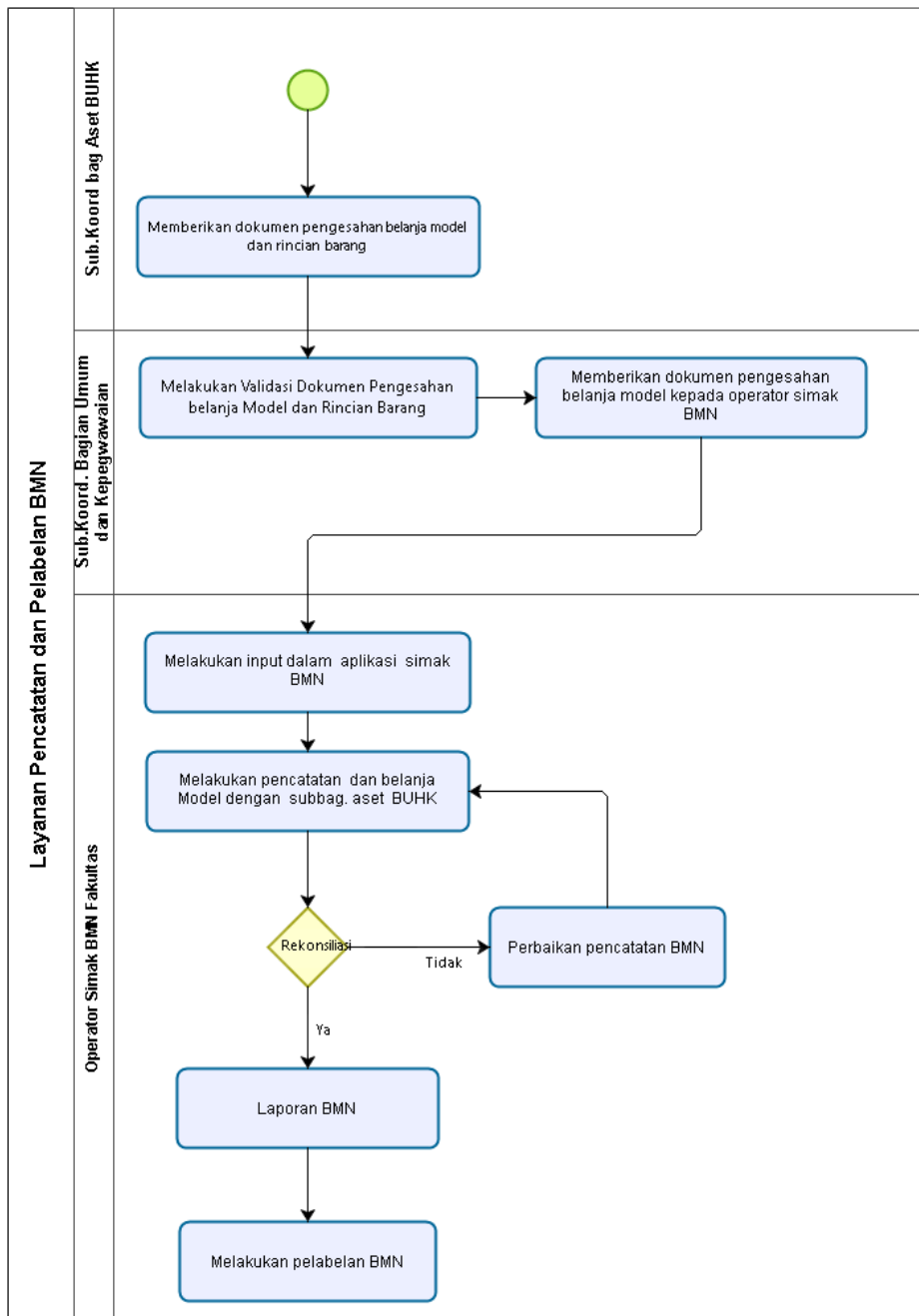

Level 4 Layanan Pengarsipan Dokumen

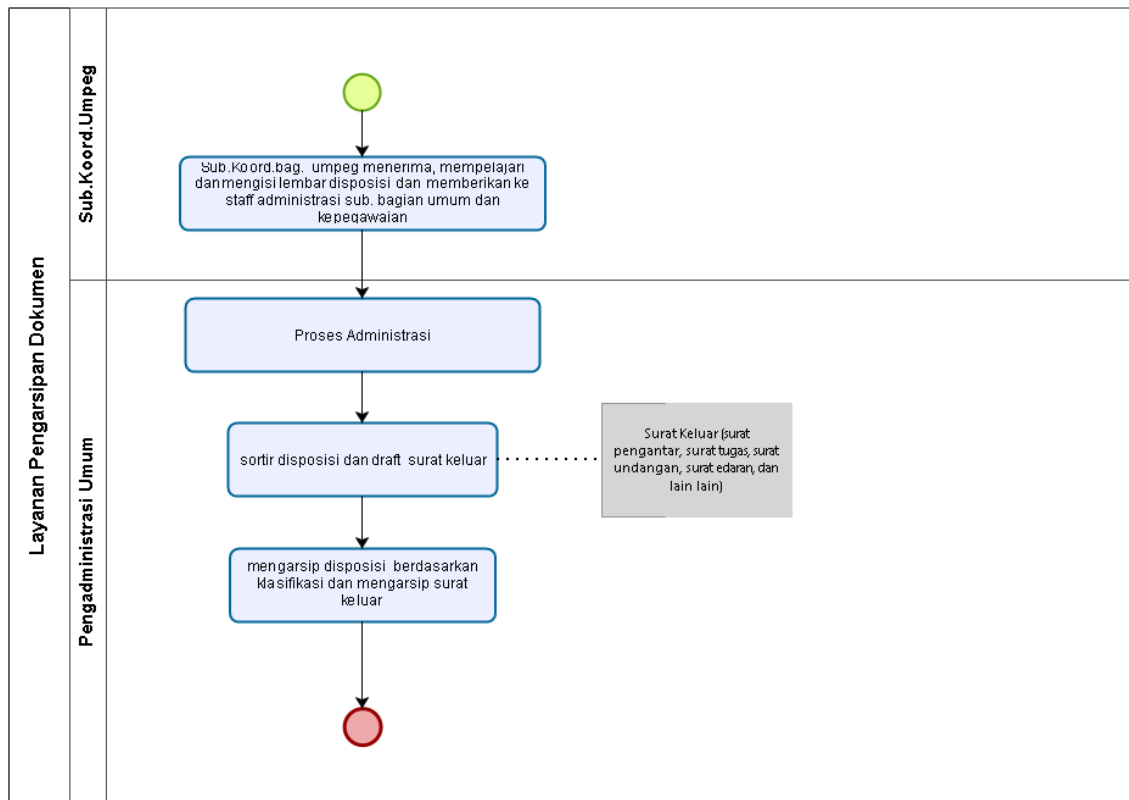

Level 4 Layanan Persediaan Masuk

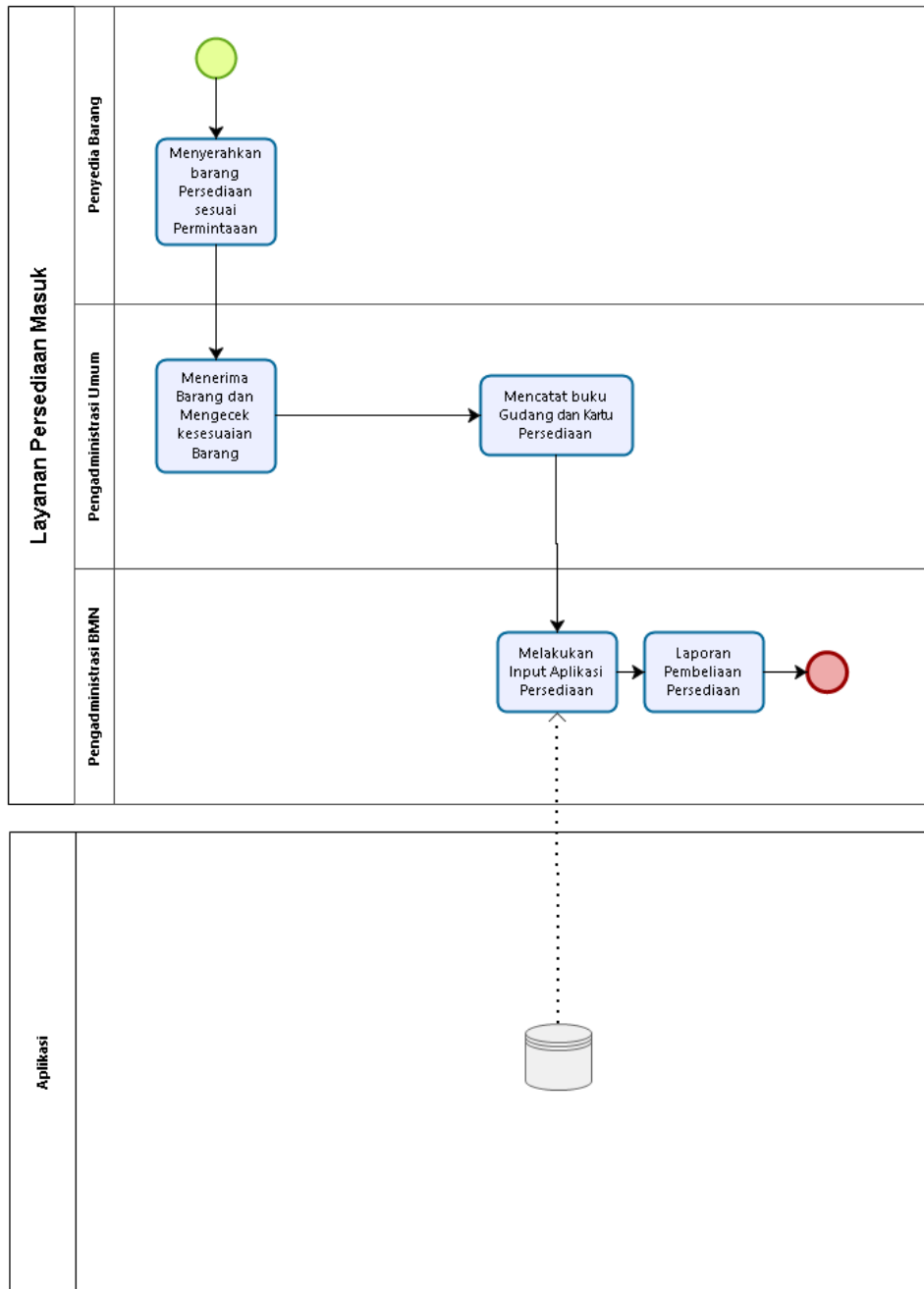

Level 4 Layanan Surat Masuk

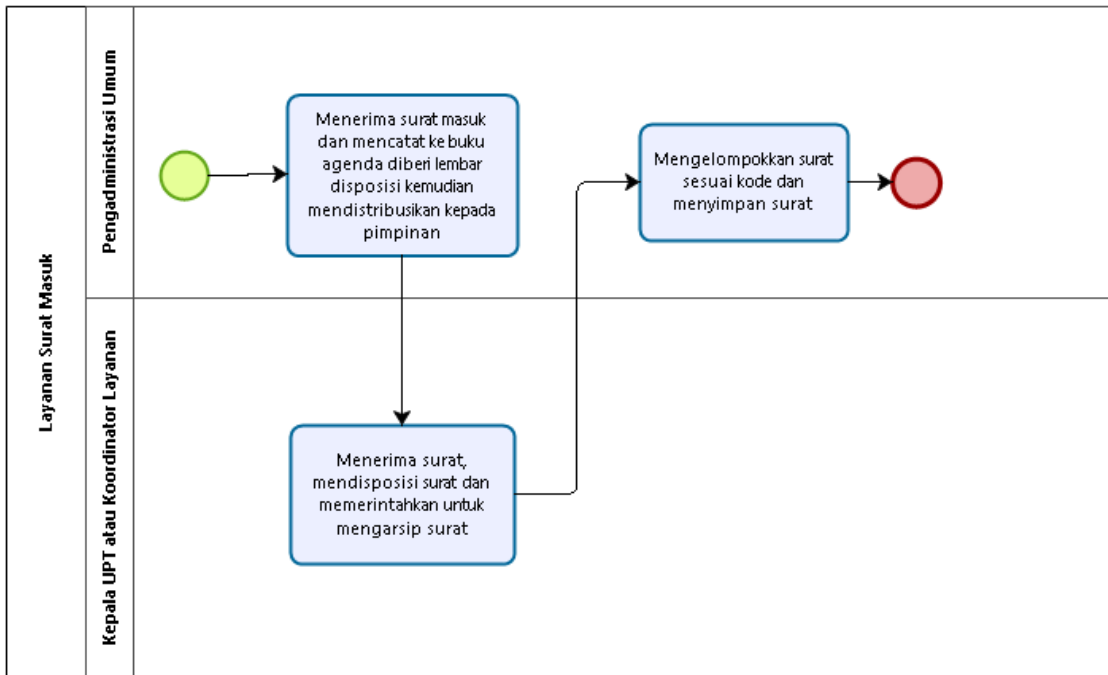

Level 4 Layanan Peminjaman Alat dan Tempat

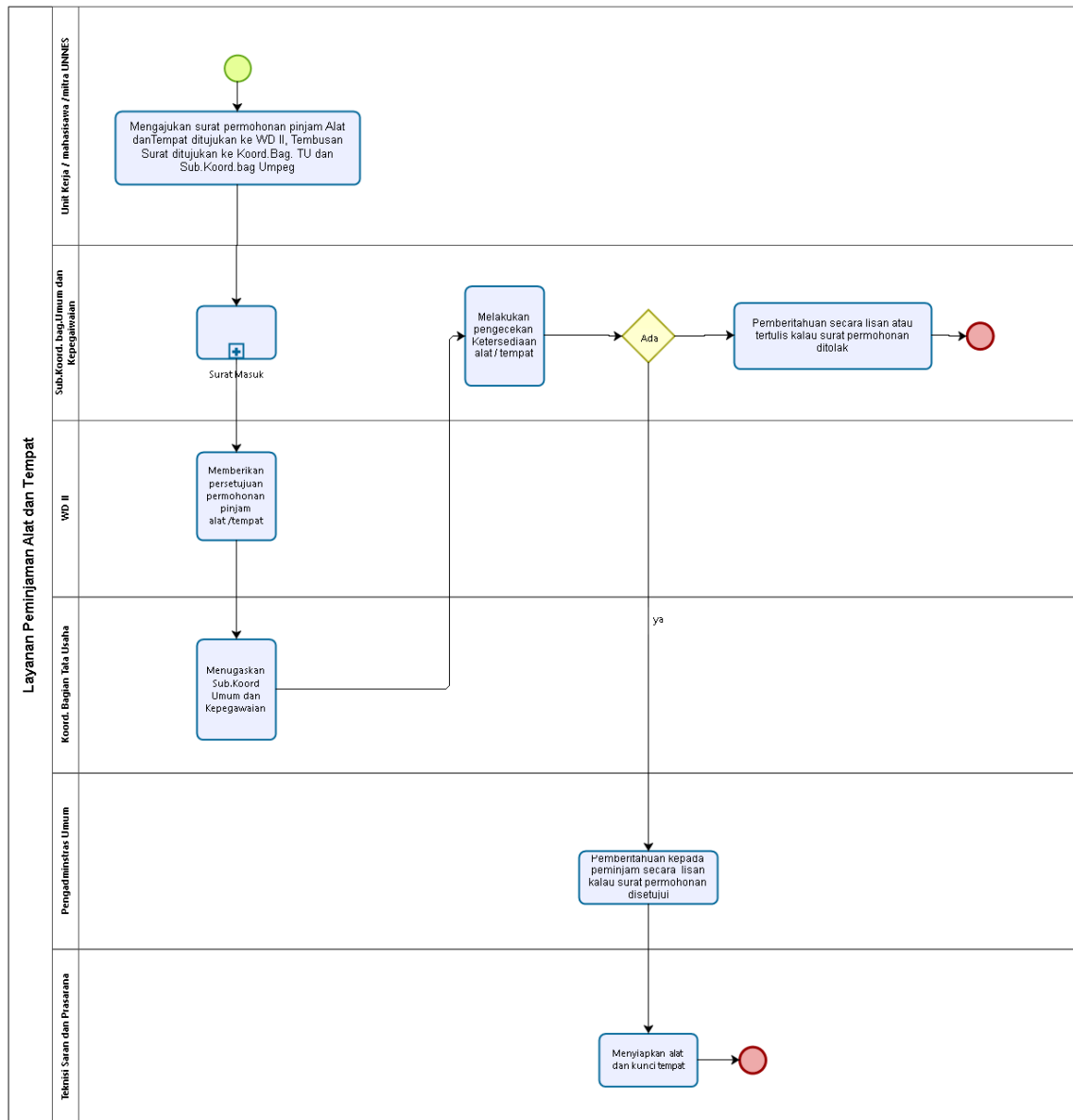

Level 4 Layanan Pengadaan Barang

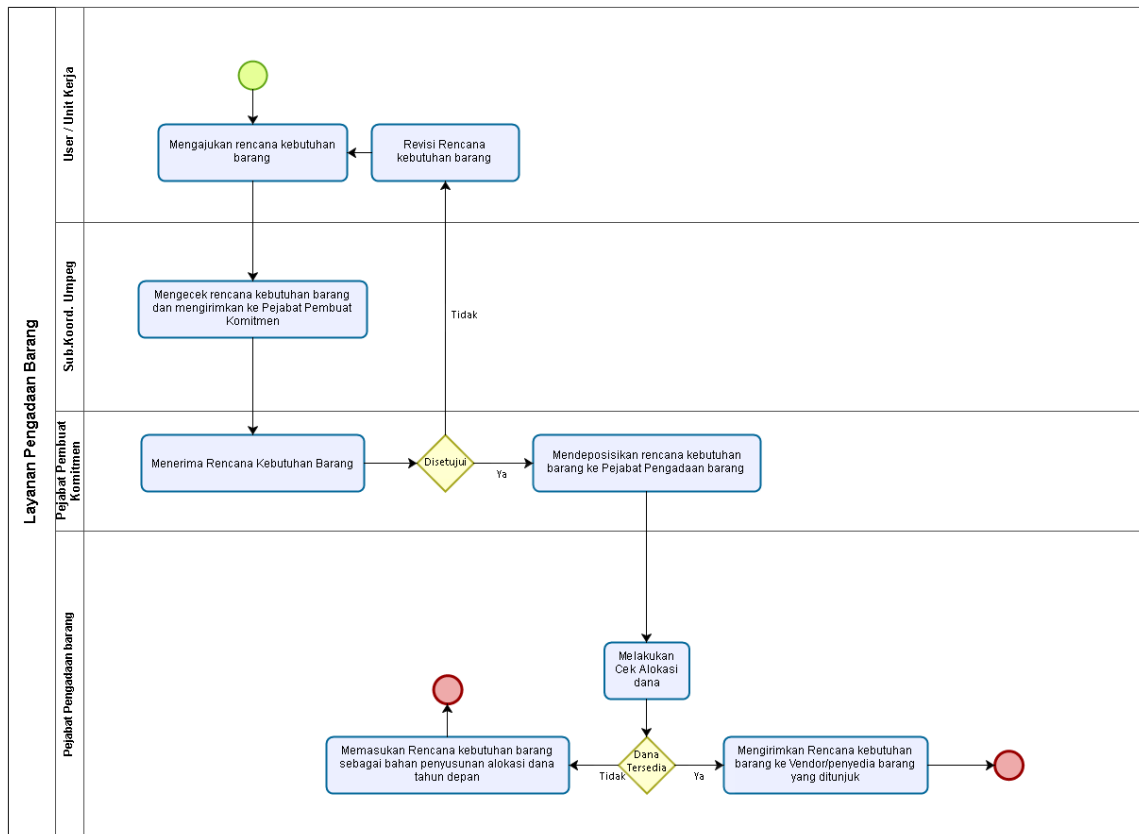

Level 4 Layanan Persediaan Keluar

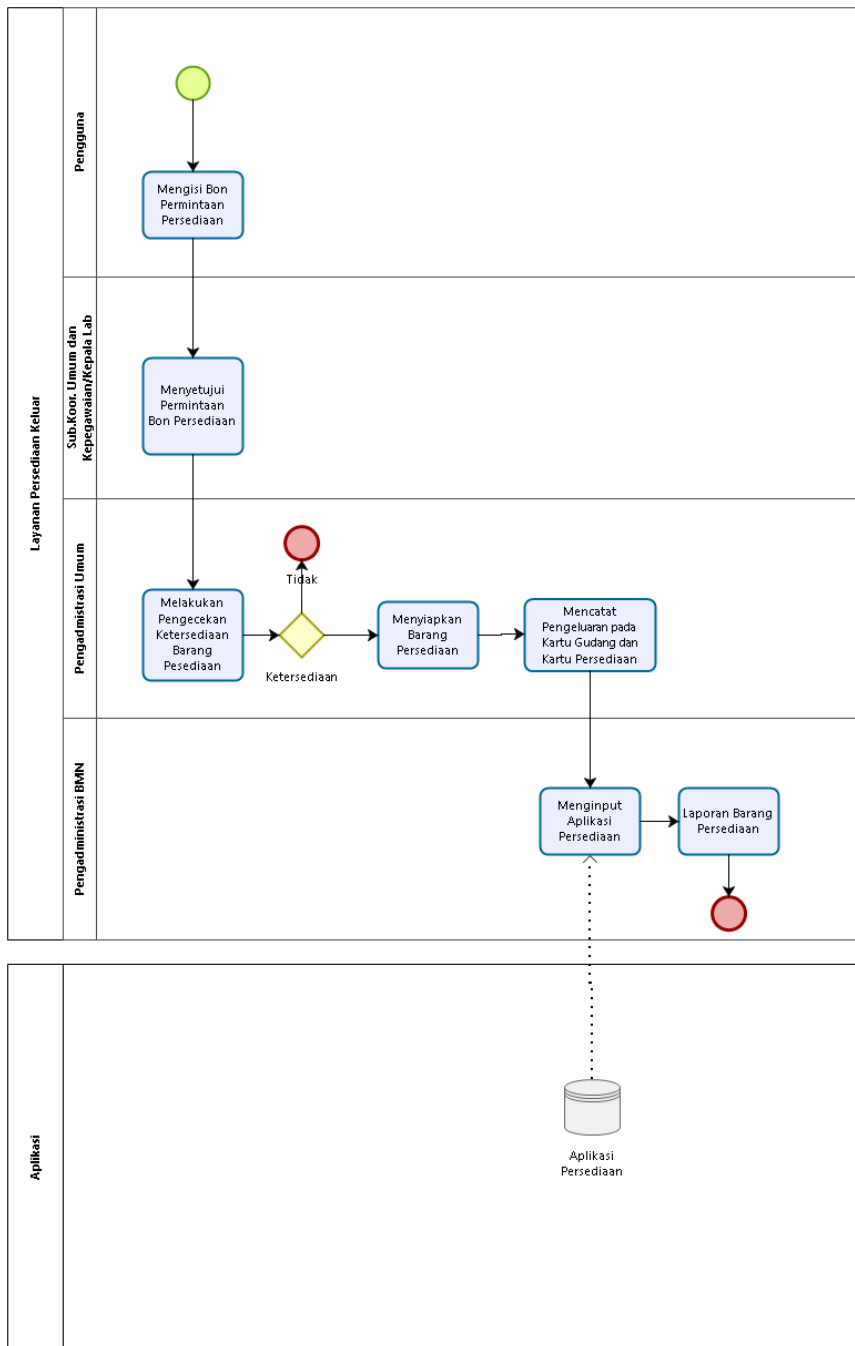

Level 4 Layanan Surat Keluar

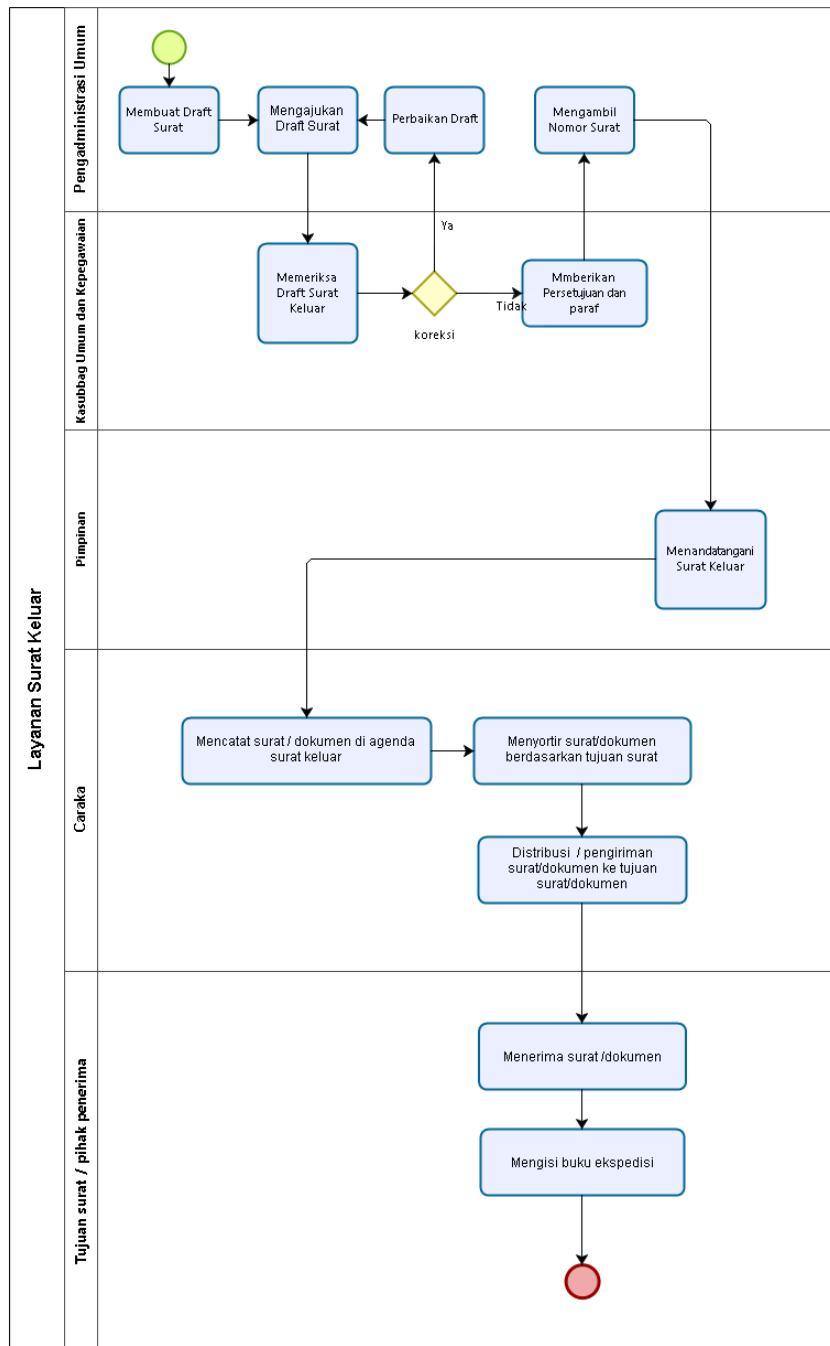

Level 4 Layanan Usul Penghapusan Barang

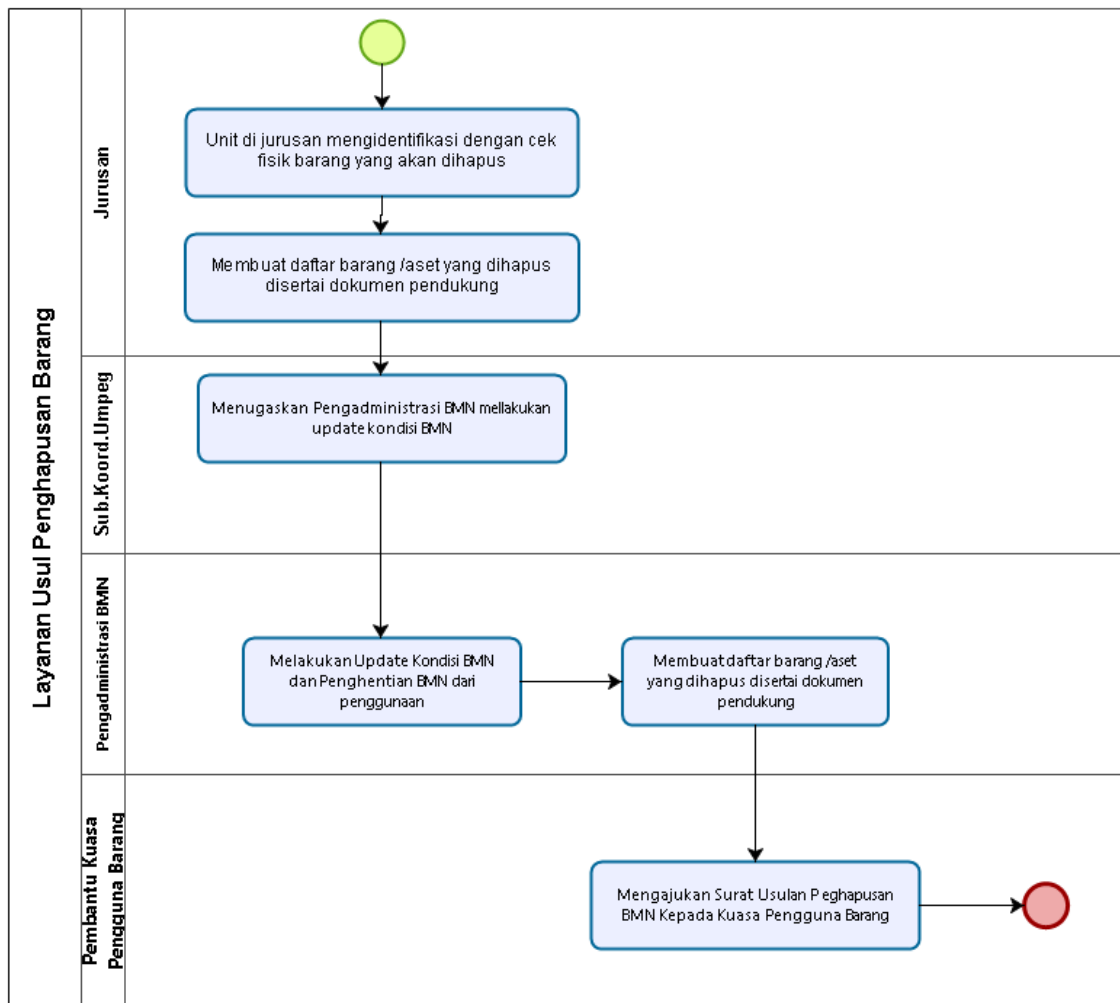

Level 3 Layanan Kepegawaian

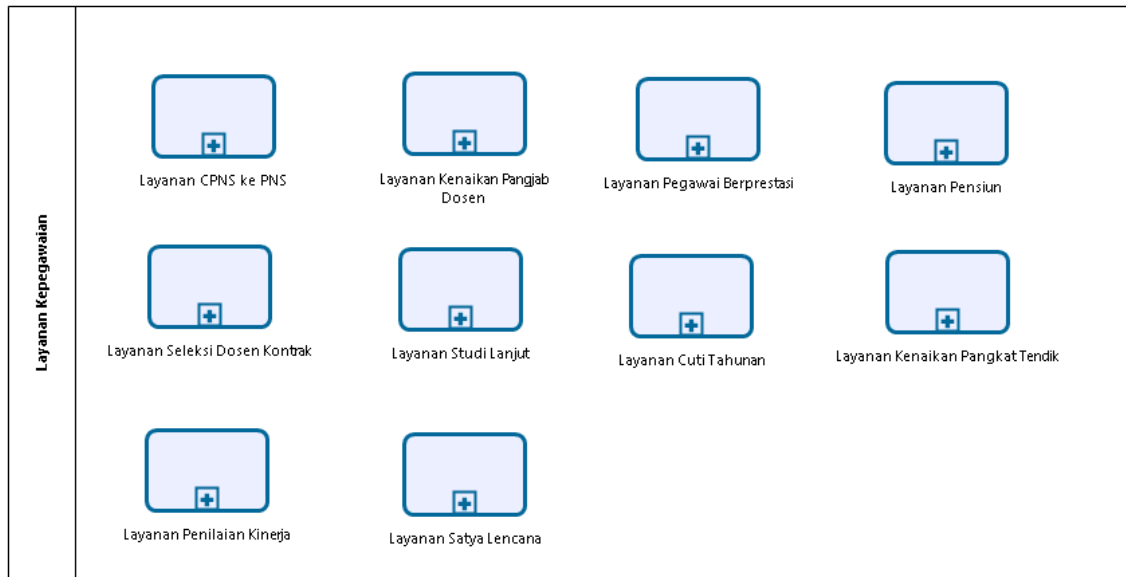

Level 4 Layanan CPNS ke PNS

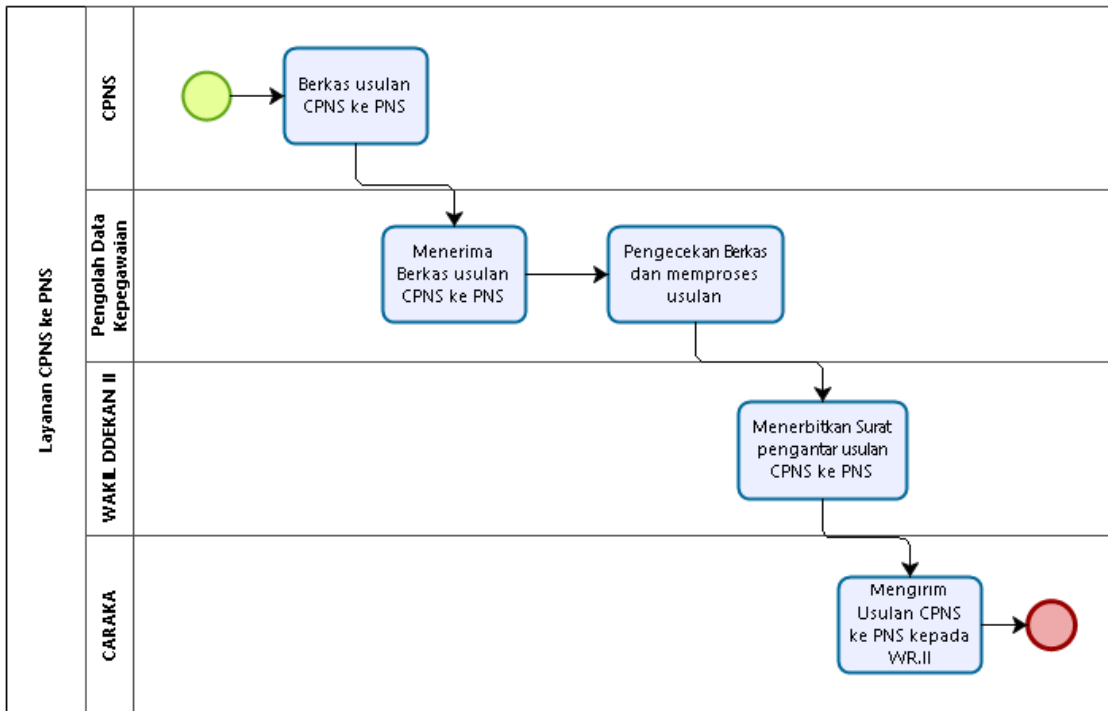

Powered by
bizagi
 Modeler

Level 4 Layanan Kenaikan Pangjab Dosen

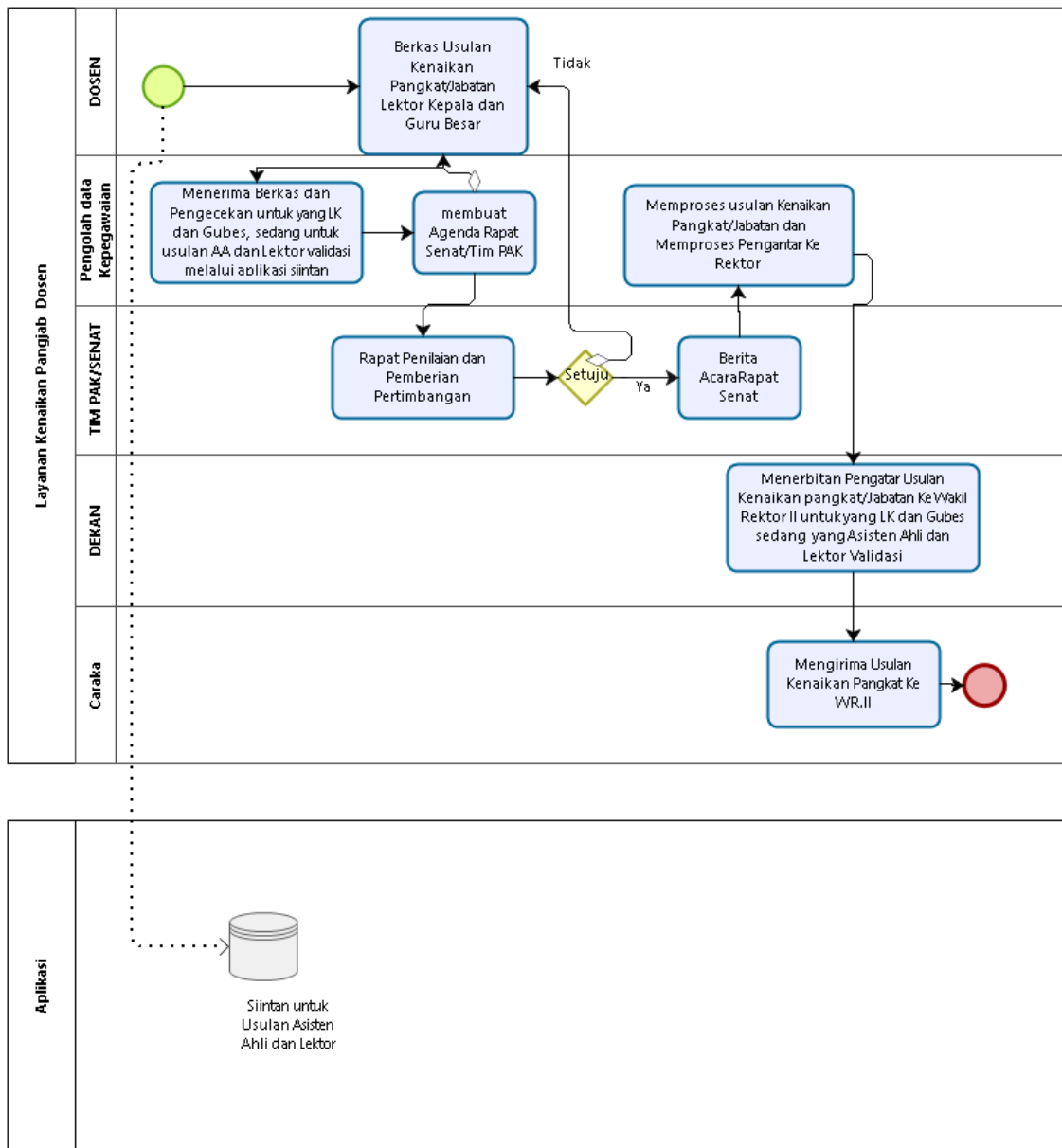

Level 4 Layanan Pegawai Berprestasi

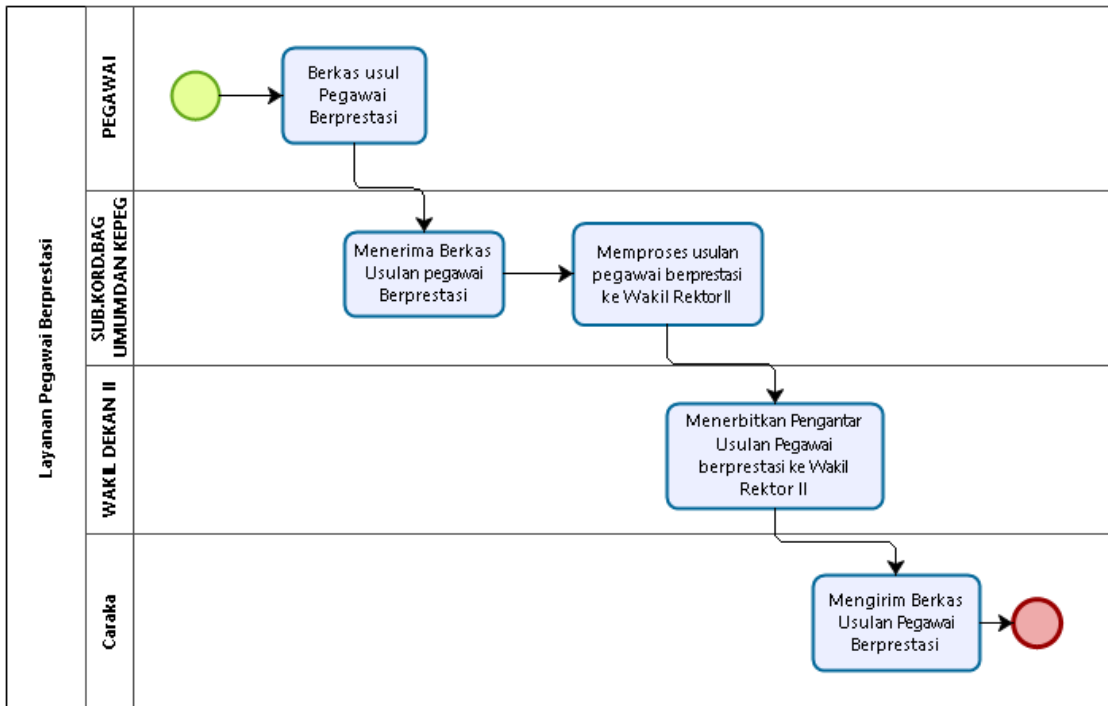

Level 4 Layanan Pensiun

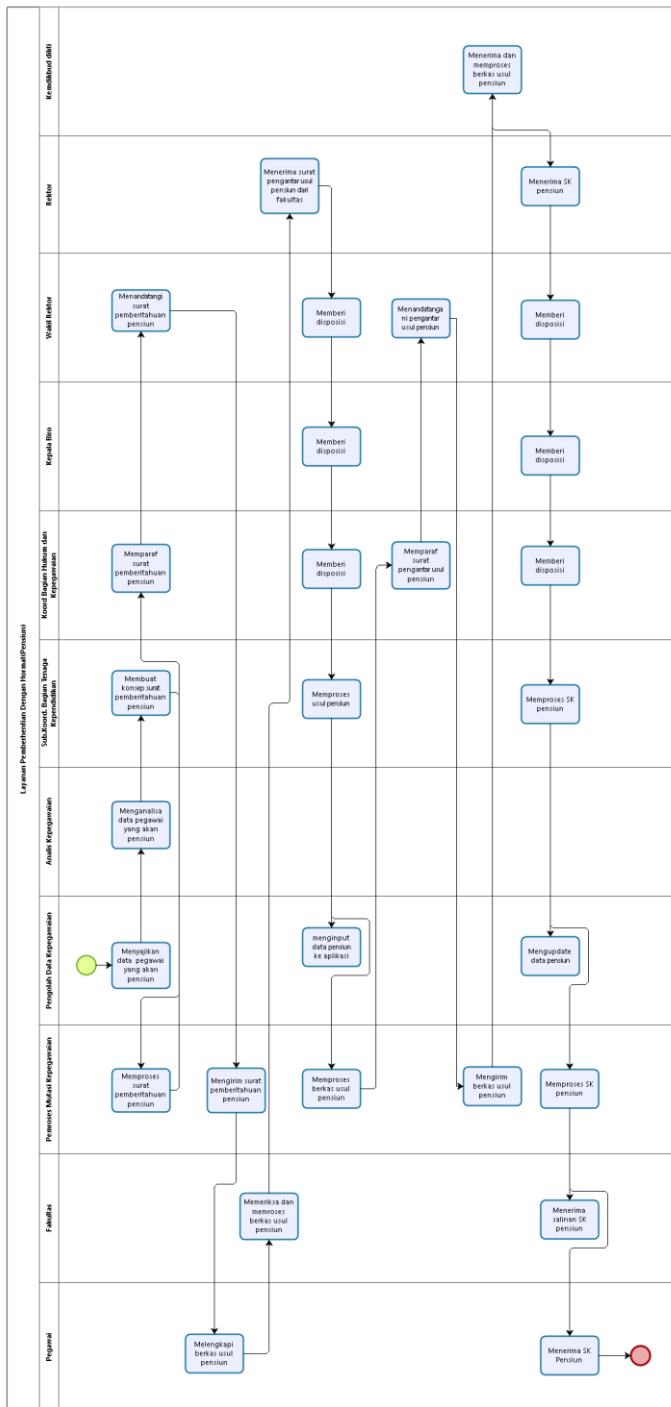

Level 4 Layanan Seleksi Dosen Kontrak

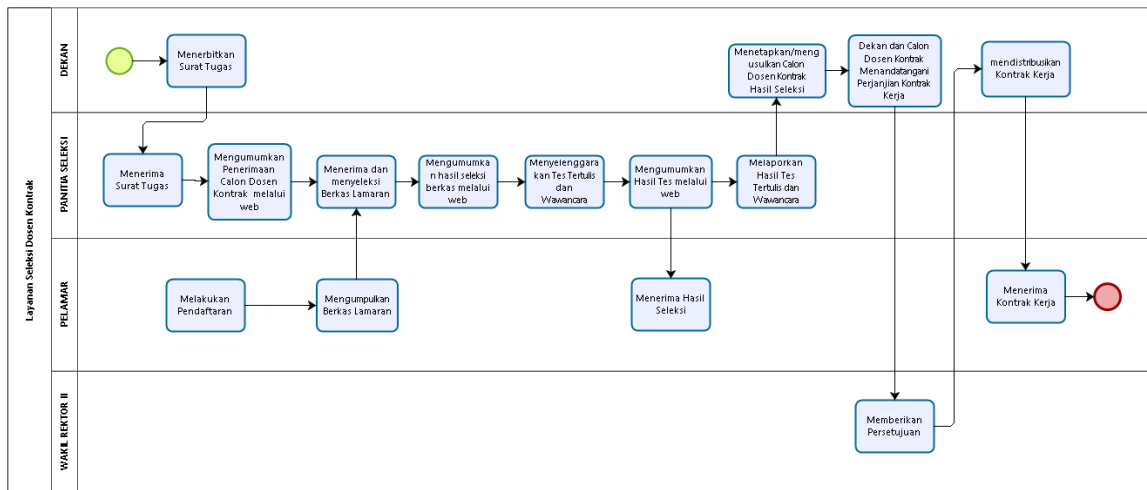

Level 4 Layanan Studi Lanjut

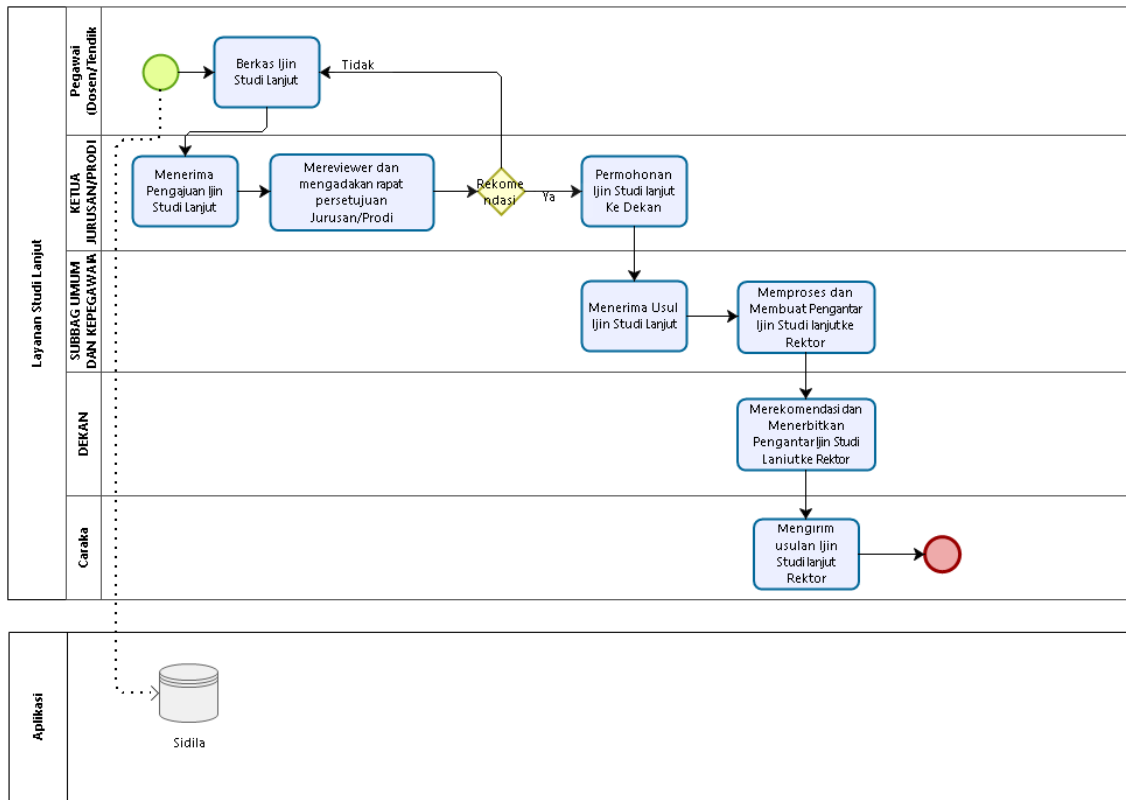

Level 4 Layanan Cuti Tahunan

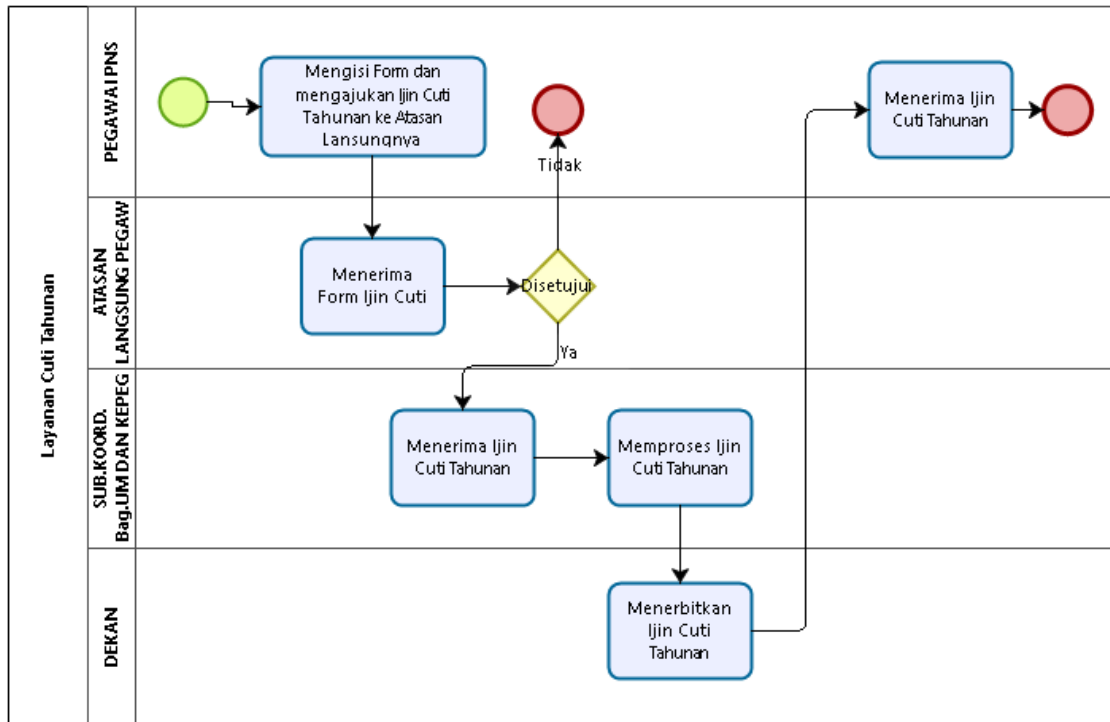

Level 4 Layanan Kenaikan Pangkat Tendik

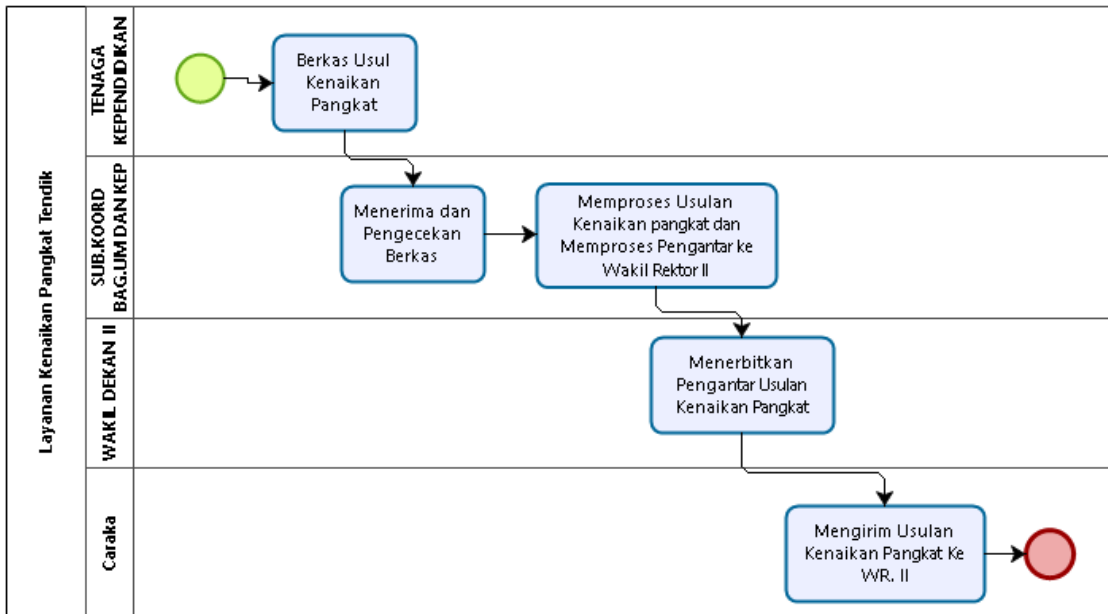

Level 4 Layanan Penilaian Kinerja

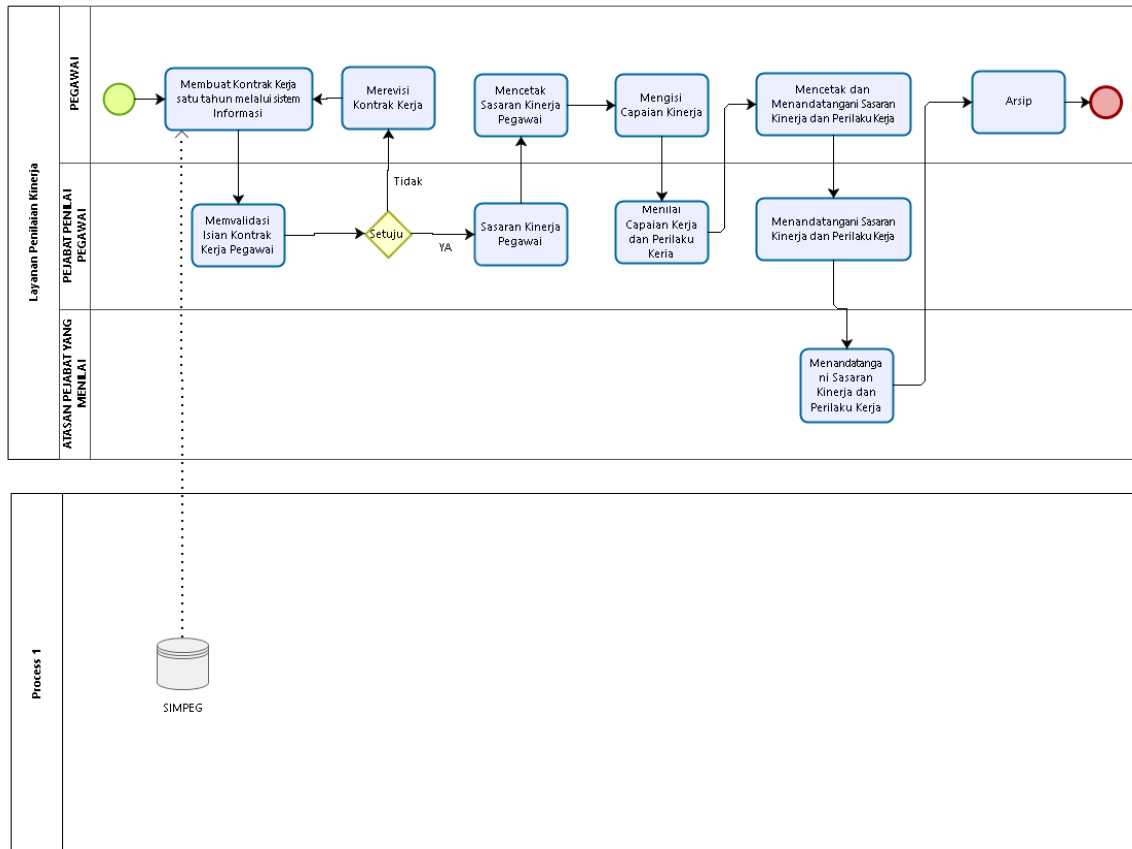

Level 4 Layanan Satya Lancana

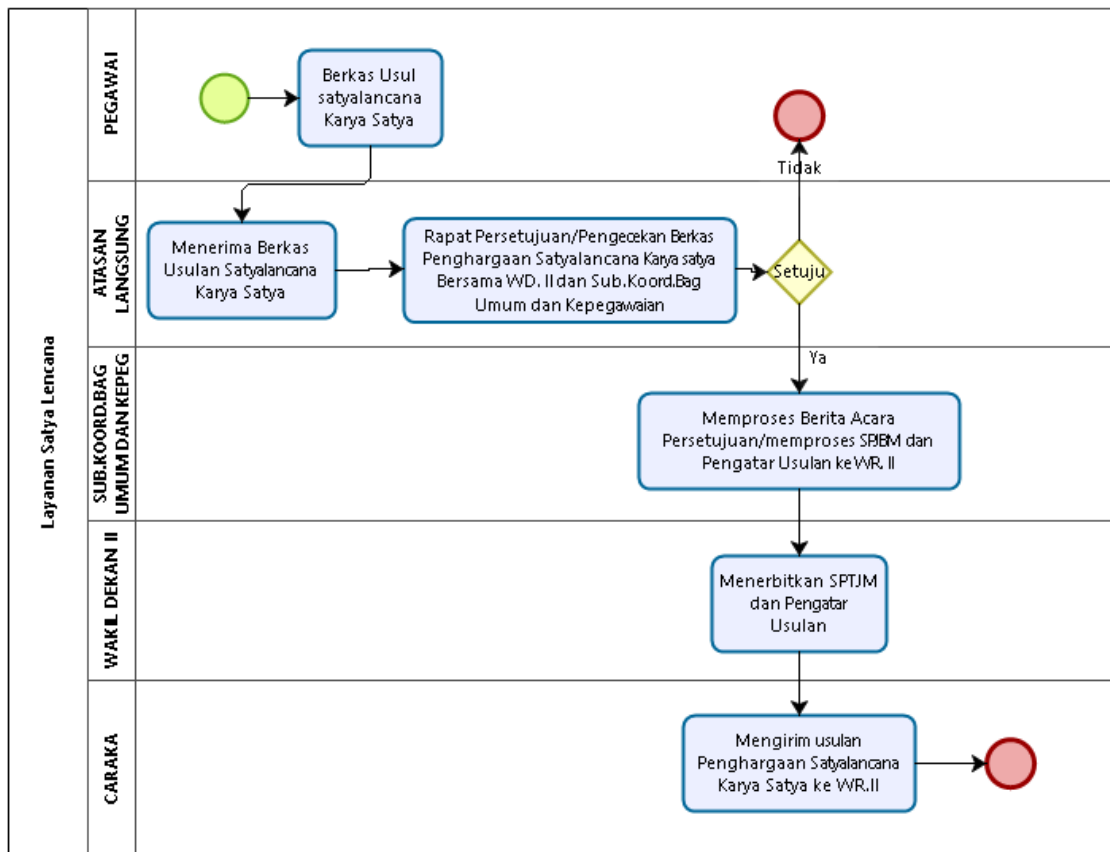

Level 3 Layanan Pengarsipan Dokumen Fakultas / Pascasarjana

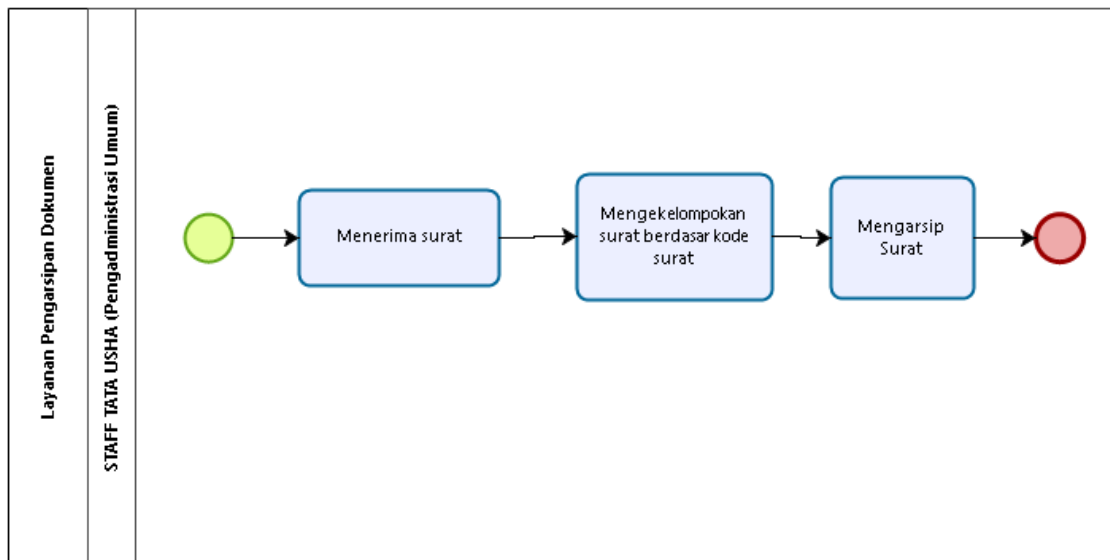

Powered by
bizagi
Modeler

Level 1 Layanan Urusan Administrasi Lembaga

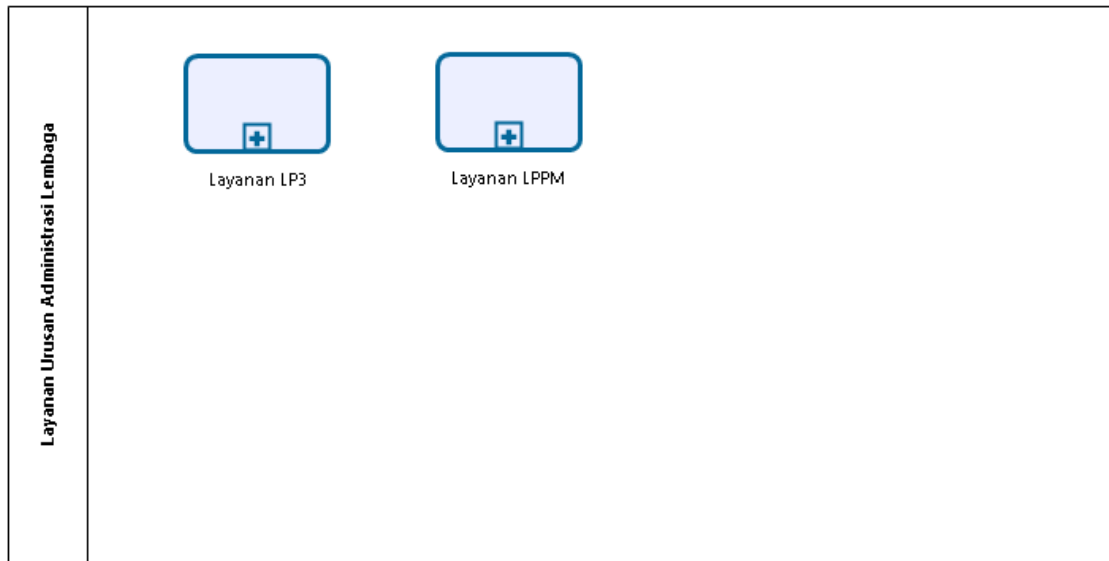

Powered by
bizagi
Modeler

Level 2 Layanan LP3

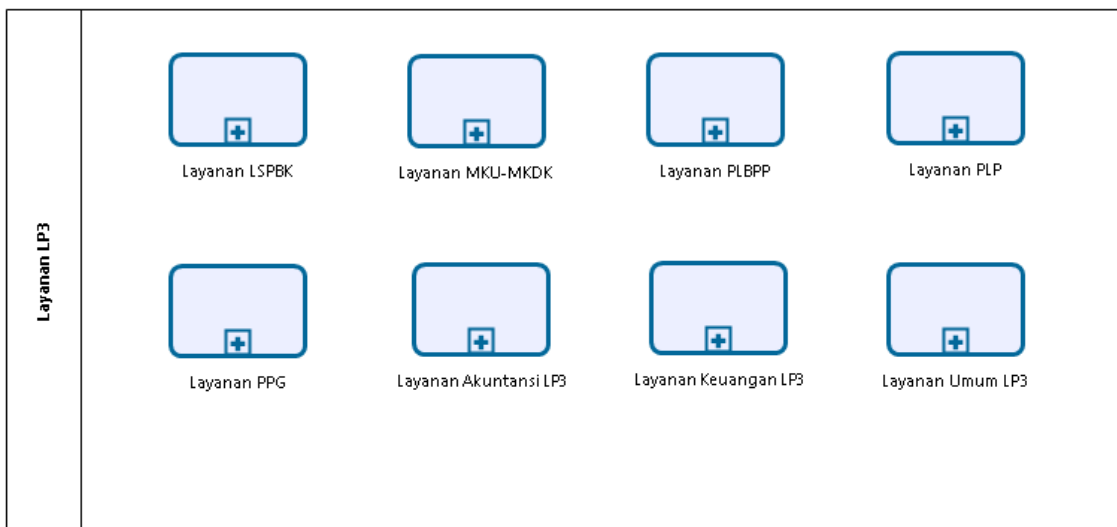

Powered by
bizagi
Modeler

Level 3 Layanan LSPBK

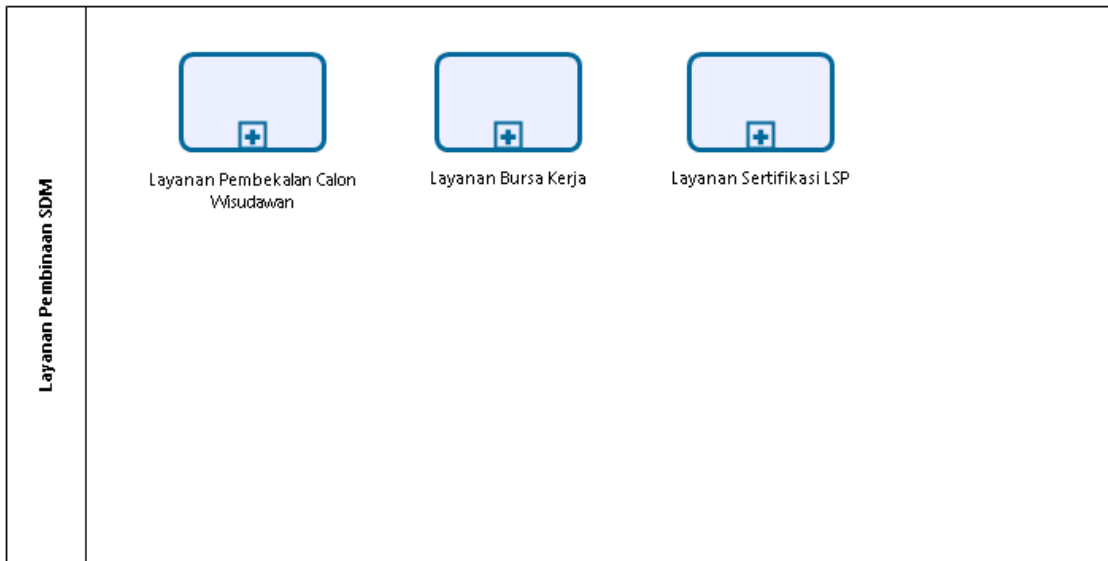

Level 4 Layanan Pembekalan Calon Wisudawan

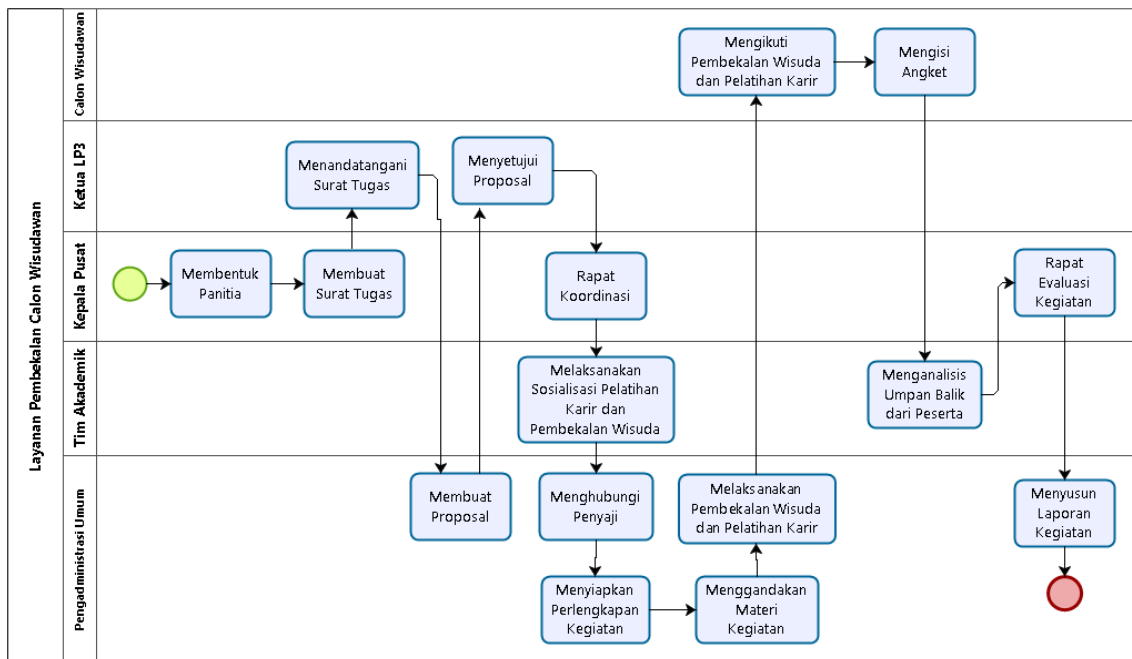

Level 4 Layanan Bursa Kerja

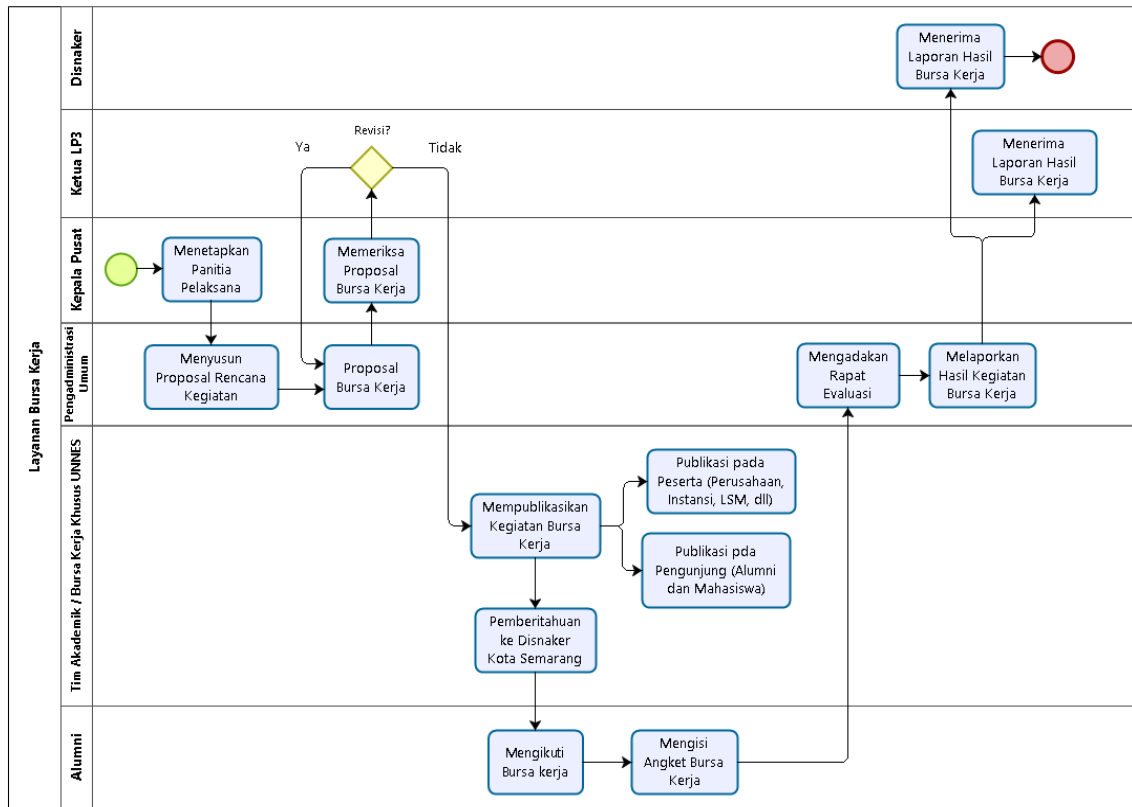

Powered by
bizagi
Modeler

Level 4 Layanan Sertifikasi LSP

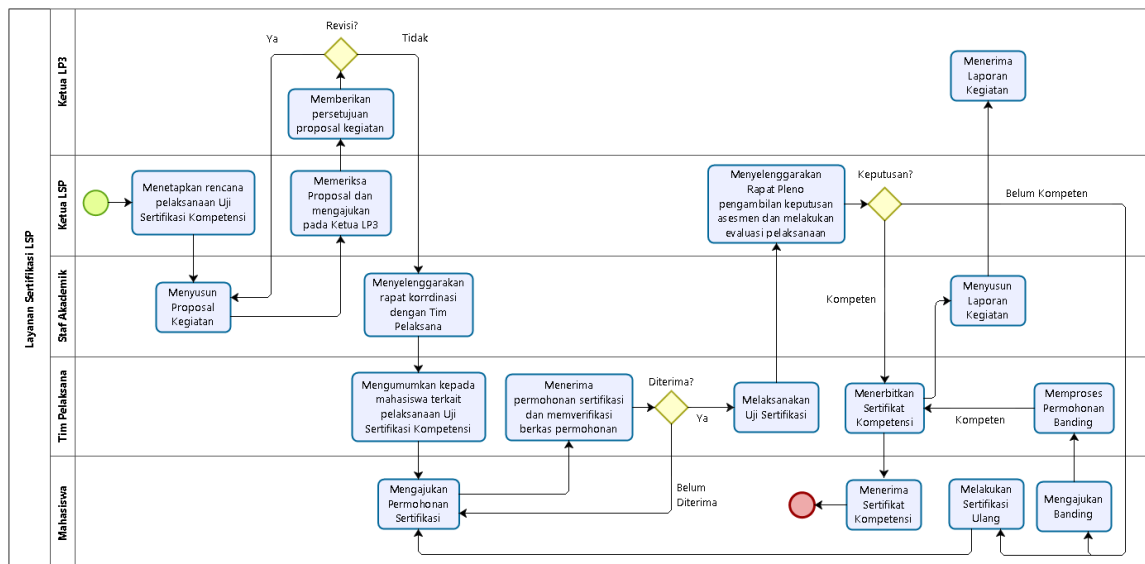

Powered by
bizagi
Modeler

Level 3 Layanan Inovasi Pembelajaran dan MKU-MKDK

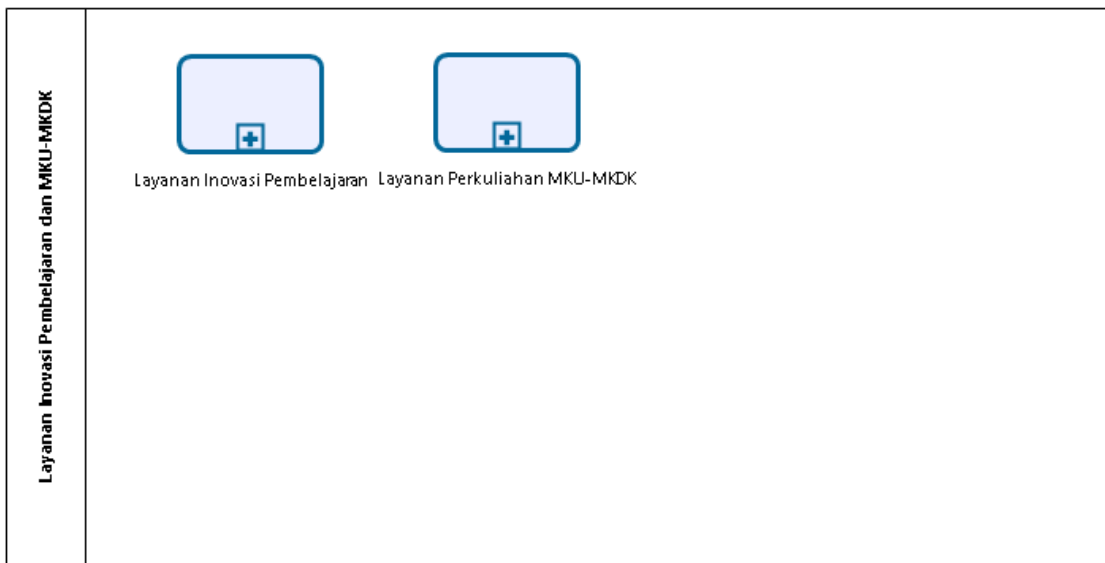

Level 4 Layanan Inovasi Pembelajaran

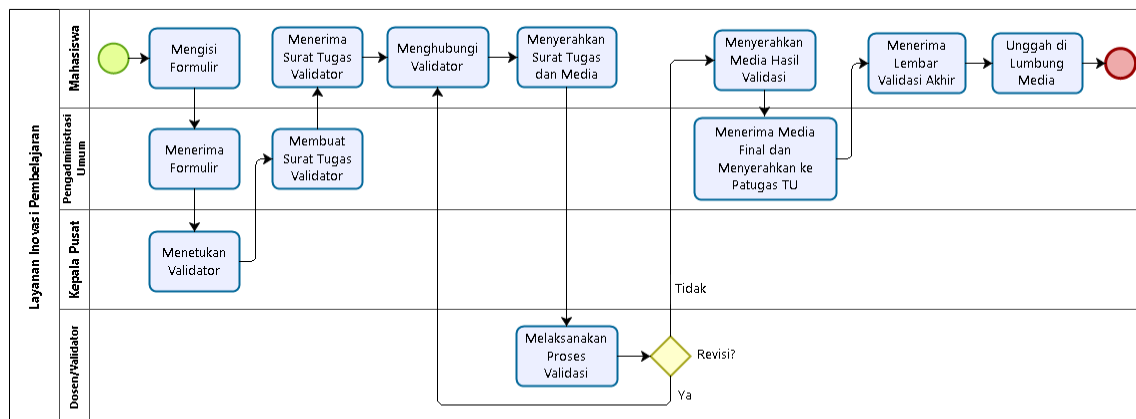

Level 4 Layanan Perkuliahan MKU-MKDK

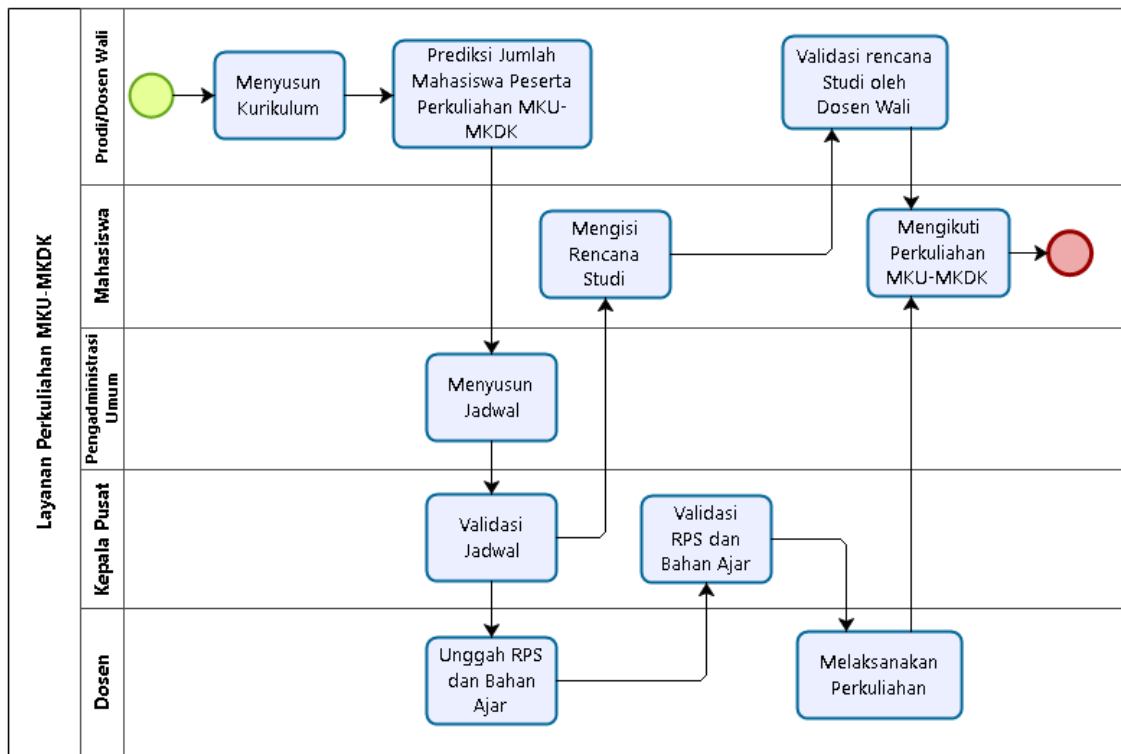

Level 3 Layanan PLBPP

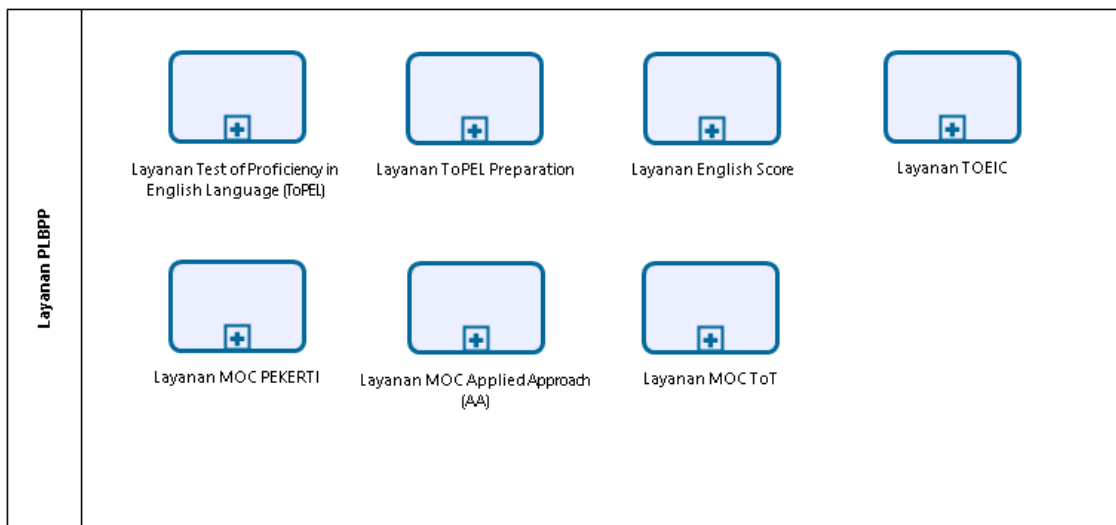

Powered by
bizagi
Modeler

Level 4 Layanan Test of Proficiency of English Language (TOPEL)

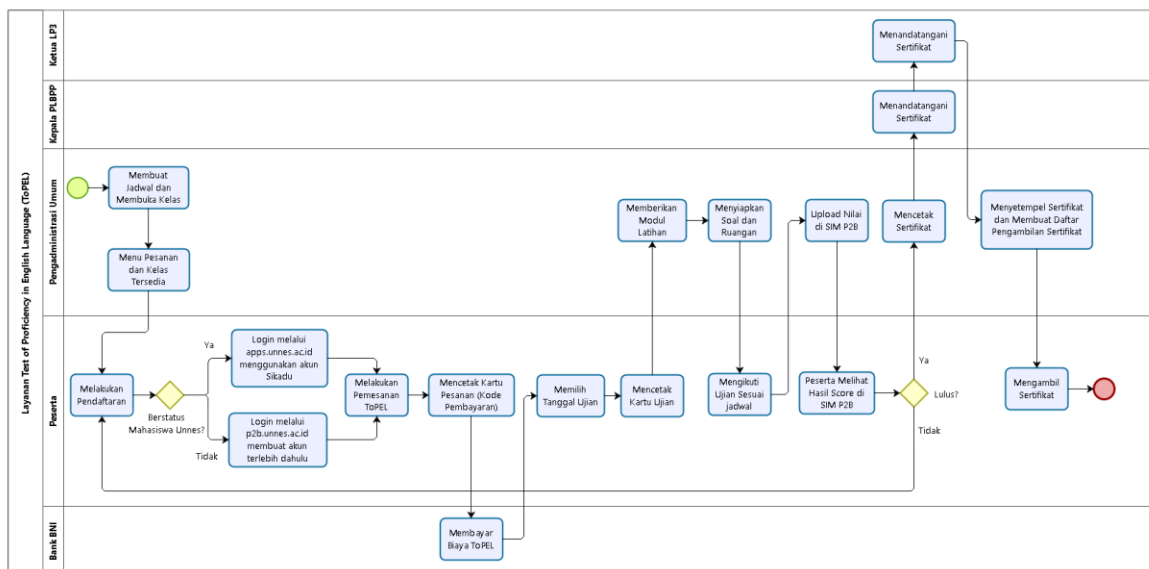

Powered by
bizagi
Modeler

Level 4 Layanan TOPEL Preparation

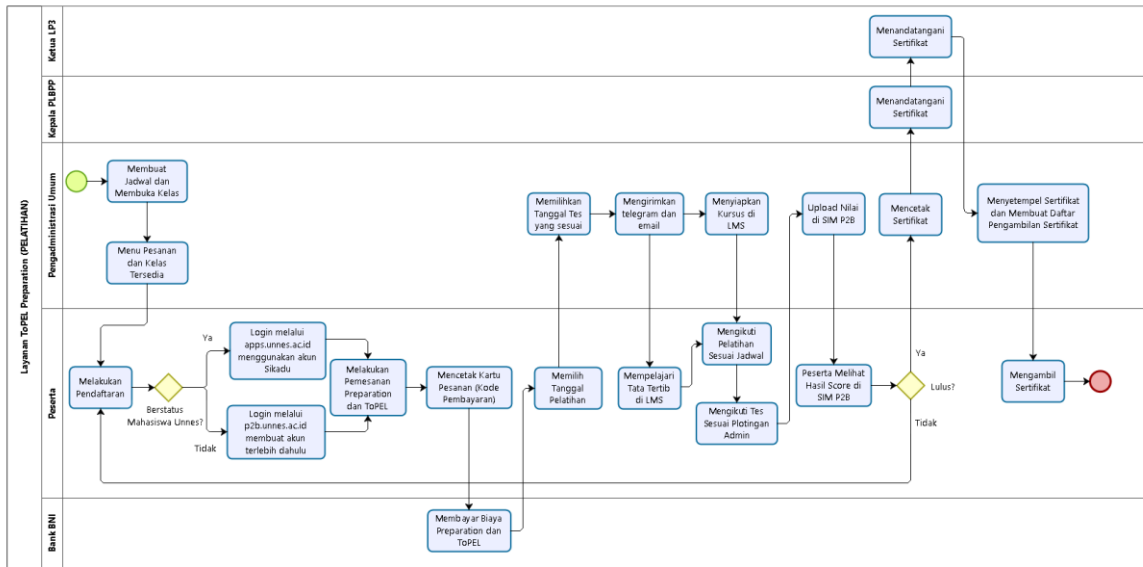

Powered by bizagi

Level 4 Layanan English Score

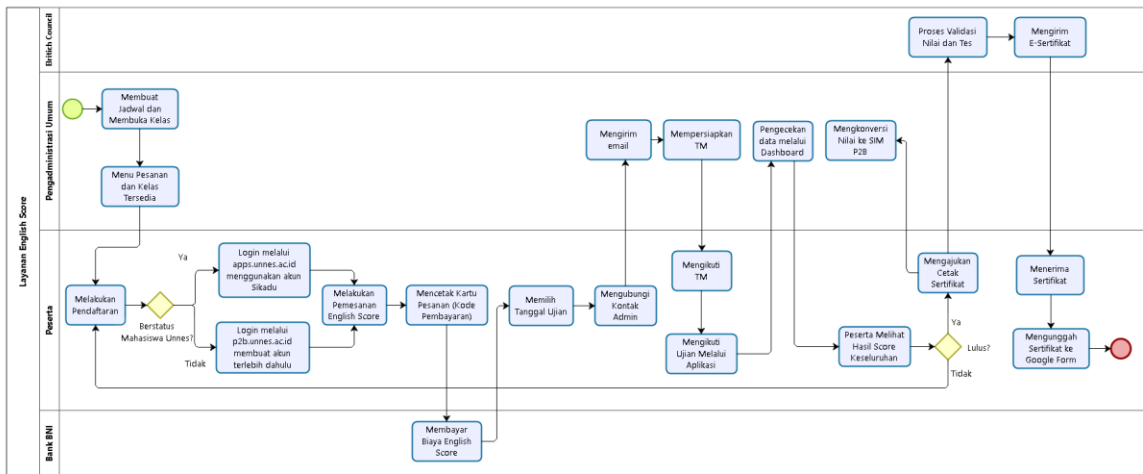

Powered by bizagi

Level 4 Layanan TOEIC

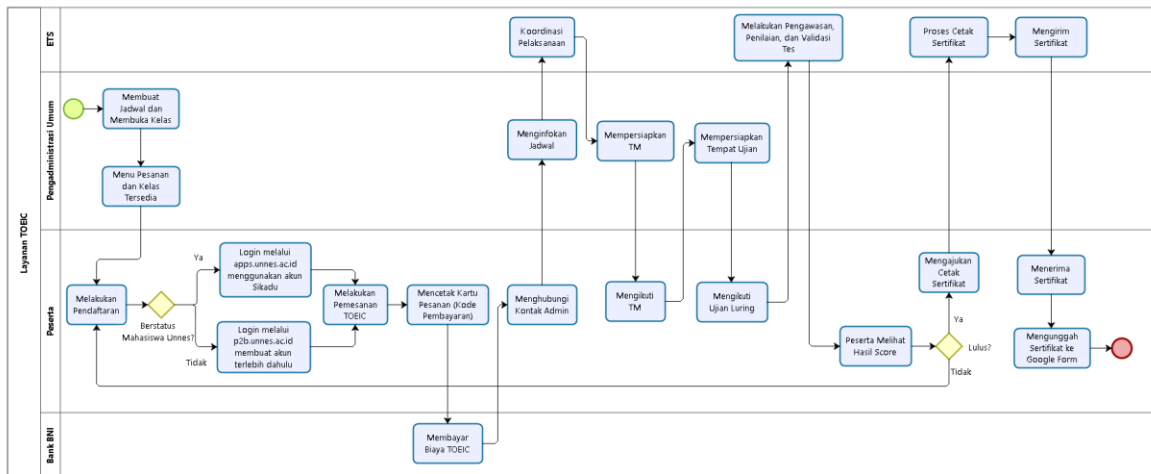

Level 4 Layanan MOC PEKERTI

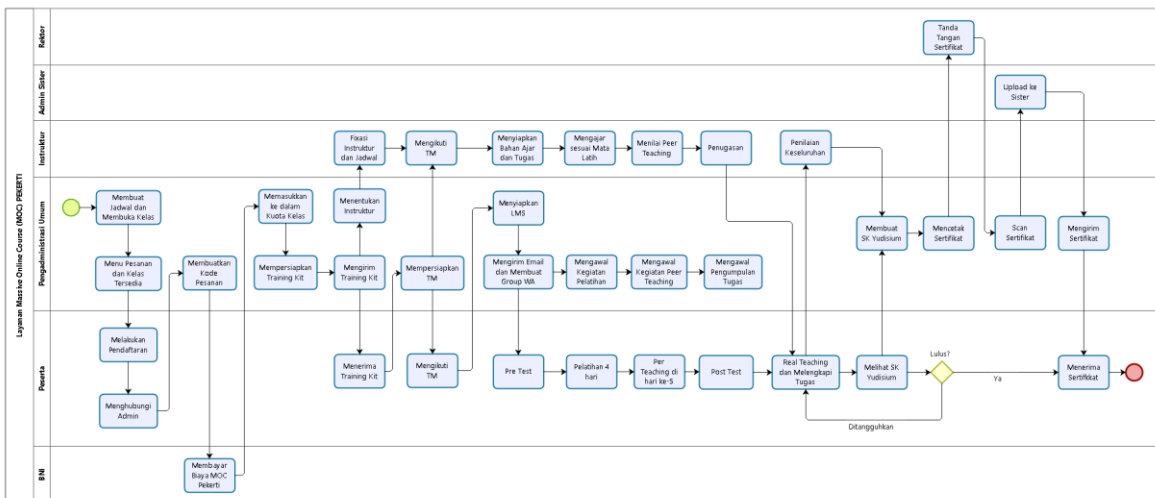

Level 4 Layanan MOC Applied Approach (AA)

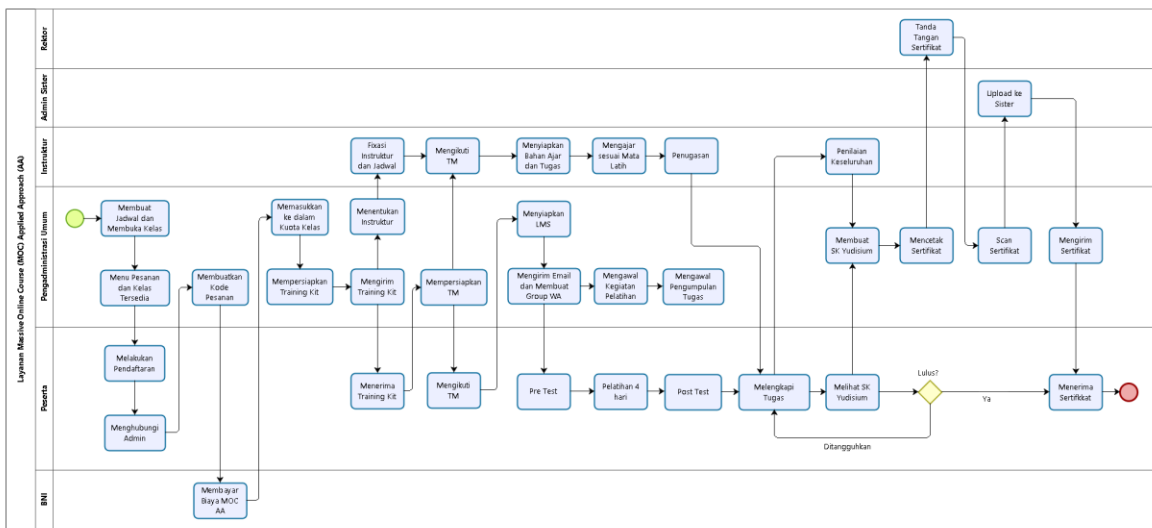

Level 4 Layanan MOC ToT

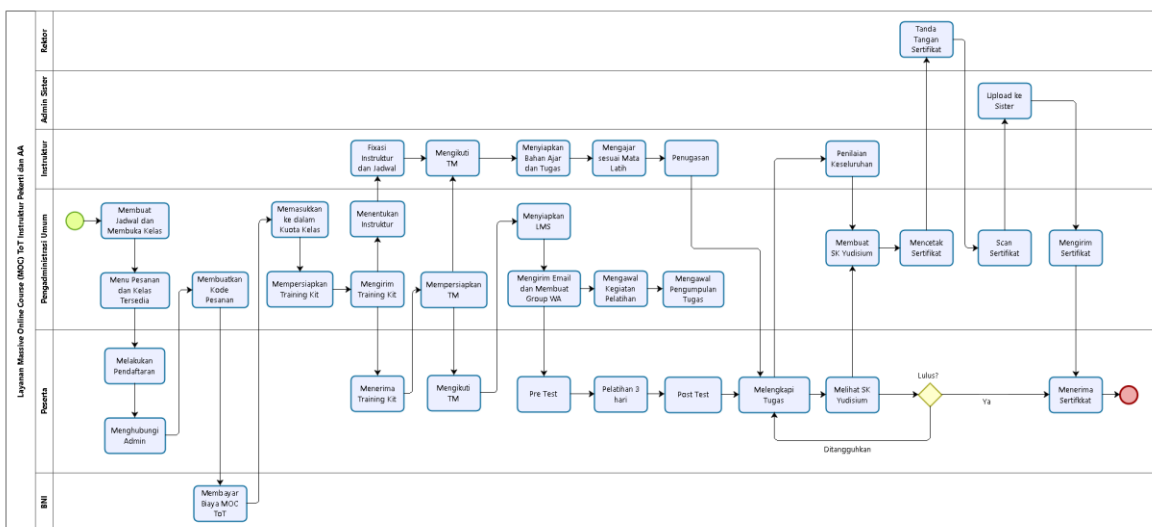

Level 3 Layanan PLP

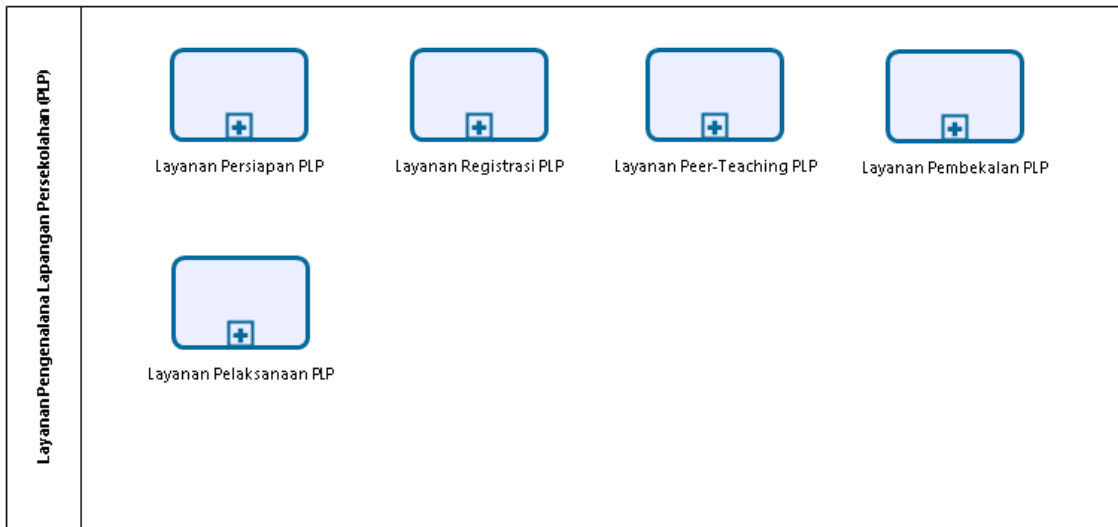

Powered by
bizagi
 Modeler

Level 4 Layanan Persiapan PLP

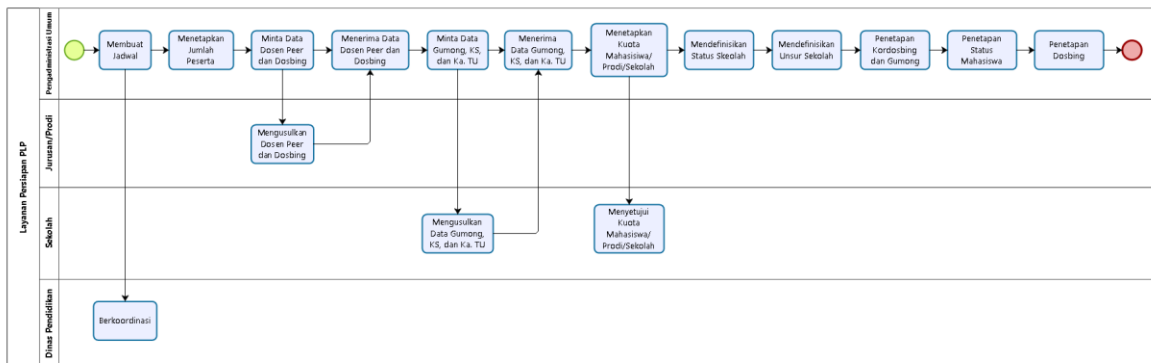

Powered by
bizagi
 Modeler

Level 4 Layanan Registrasi PLP

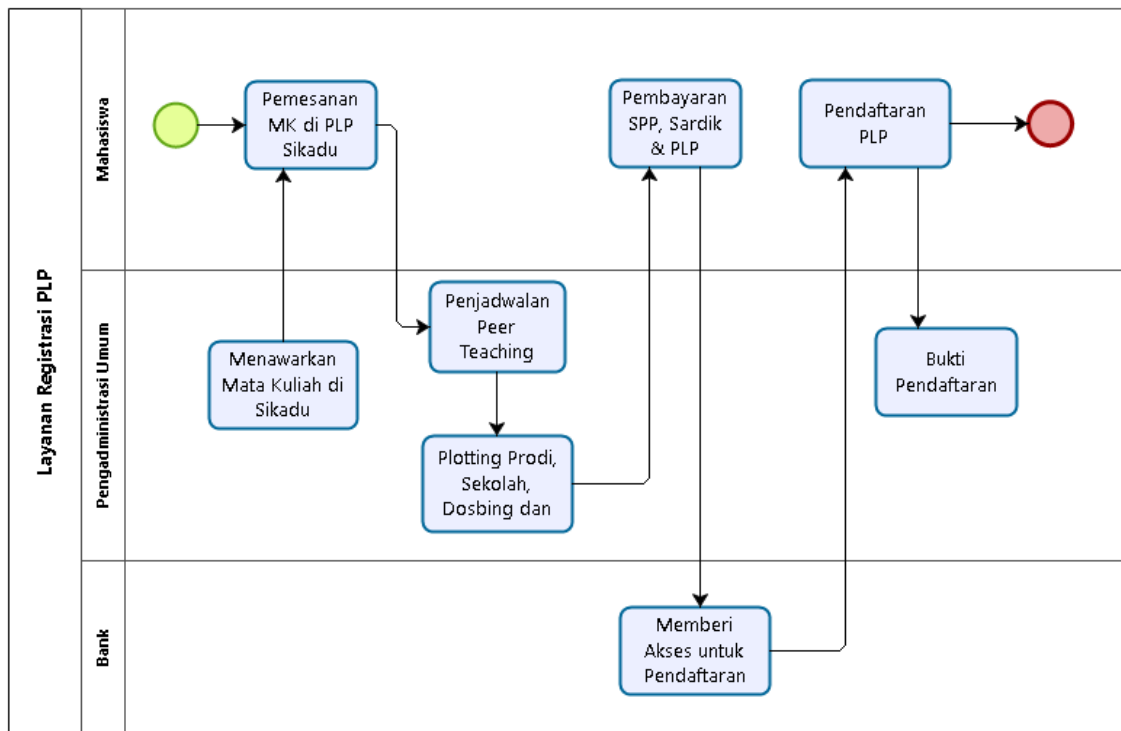

Level 4 Layanan Peer-Teaching PLP

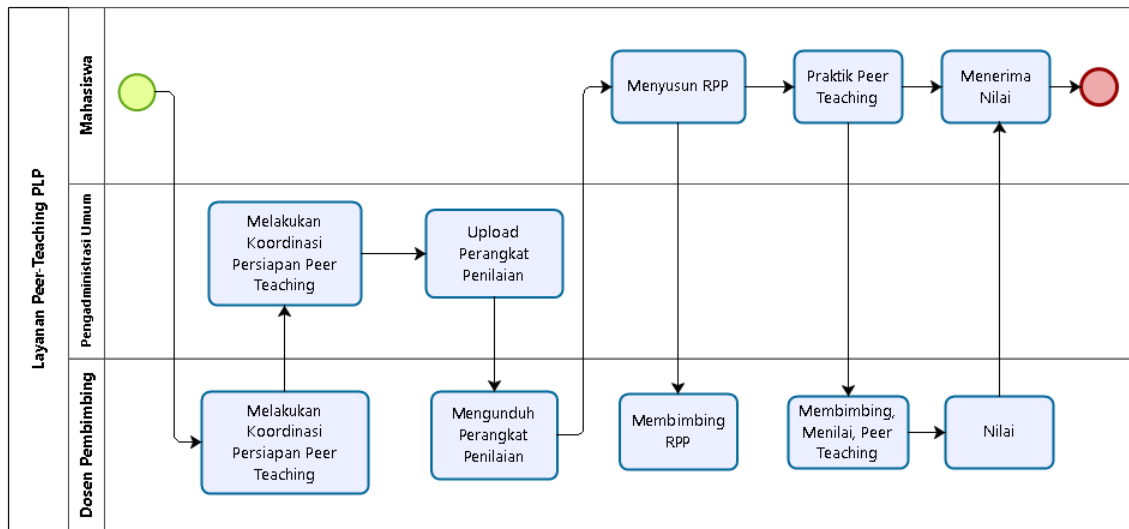

Powered by
bizagi
Modeler

Level 4 Layanan Pembekalan PLP

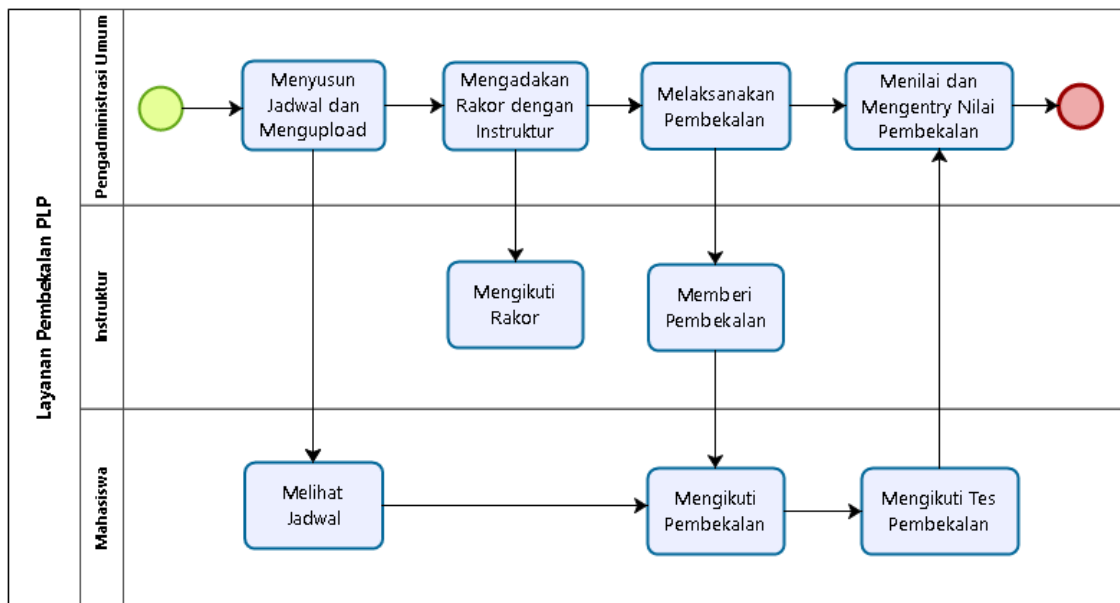

Powered by
bizagi
Modeler

Level 4 Layanan Pelaksanaan PLP

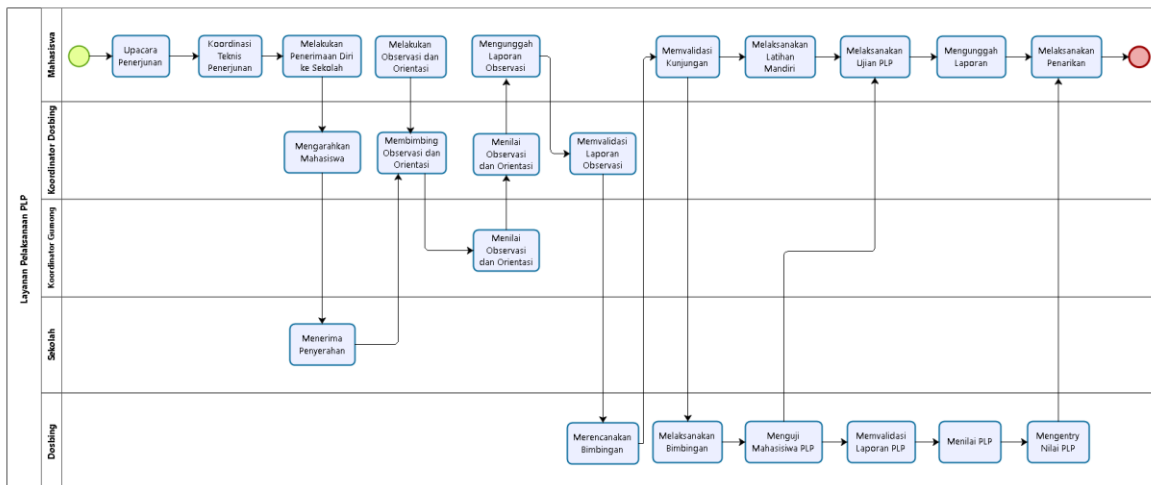

Powered by
bizagi
Modeler

Level 3 Layanan PPG

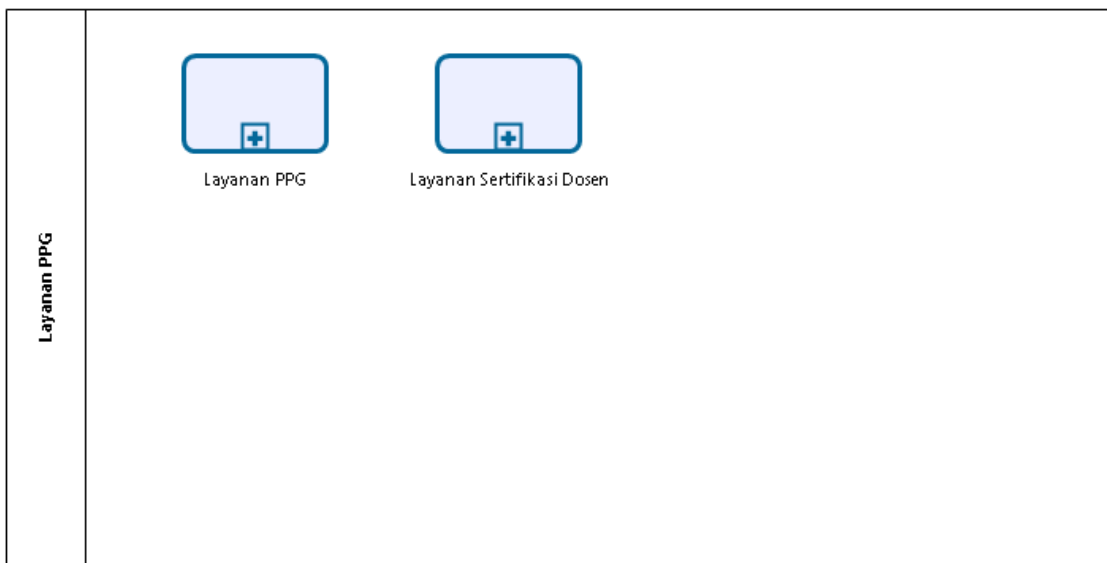

Powered by
bizagi
Modeler

Level 4 Layanan PPG

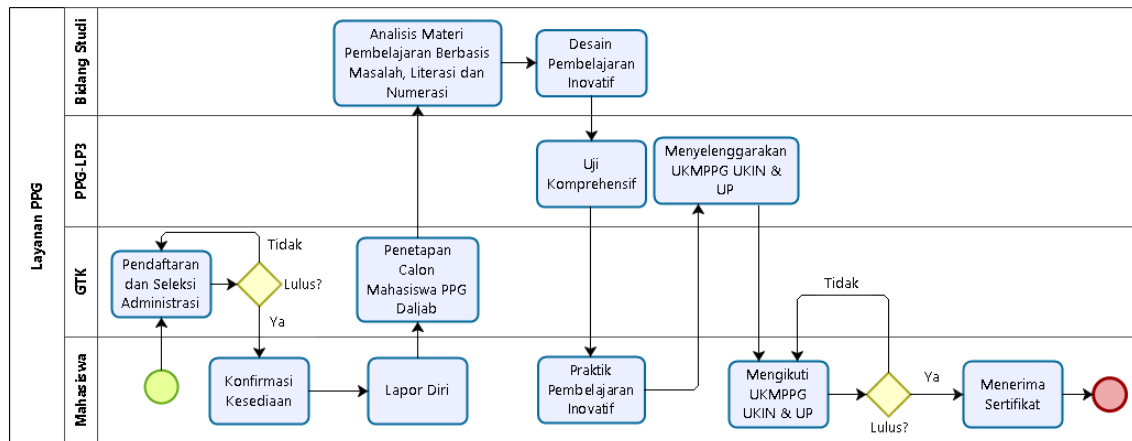

Powered by
bizagi
Modeler

Level 4 Layanan Sertifikasi Dosen

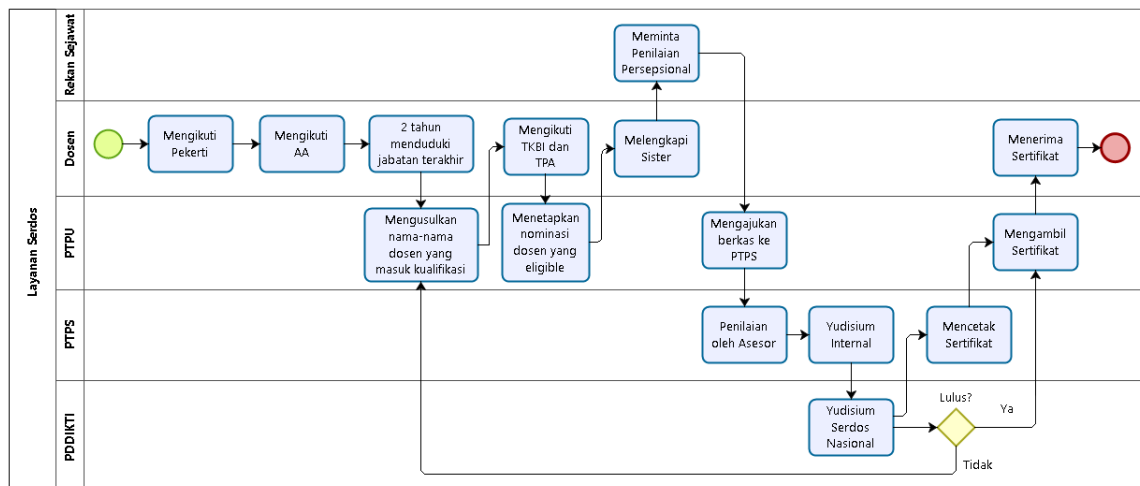

Powered by
bizagi
Modeler

Level 3 Layanan Akuntansi LP3

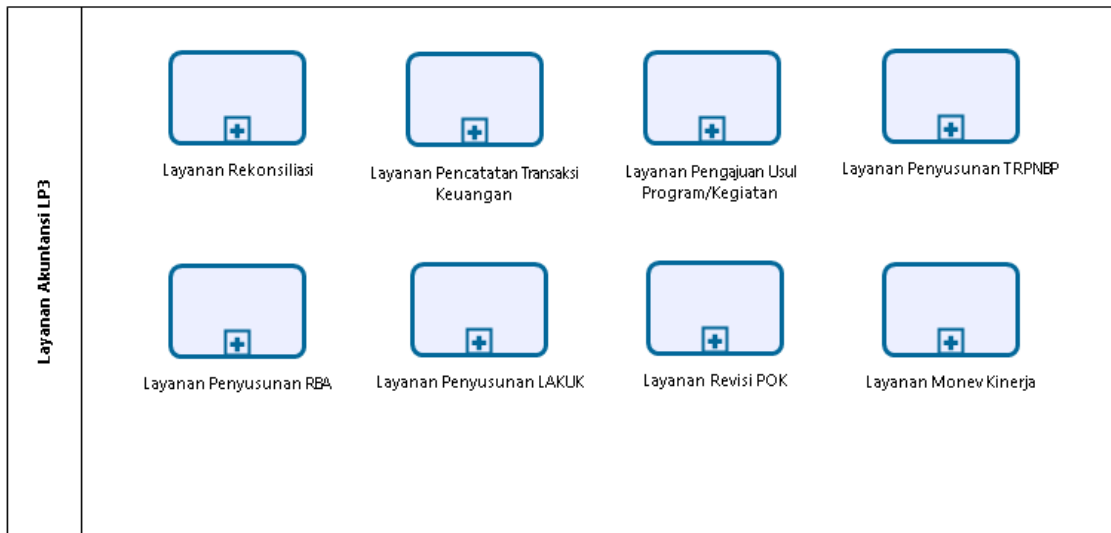

Level 4 Layanan Rekonsiliasi

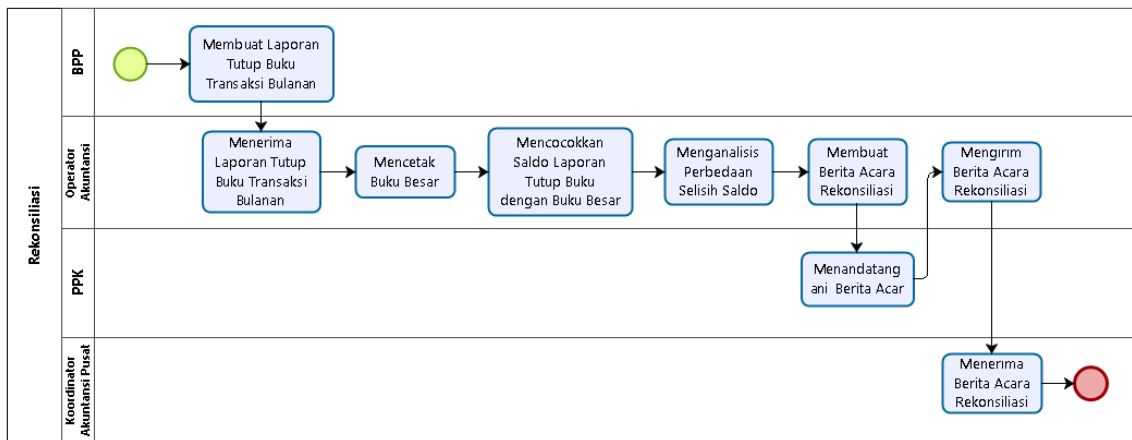

Level 4 Layanan Pencatatan Transaksi Keuangan

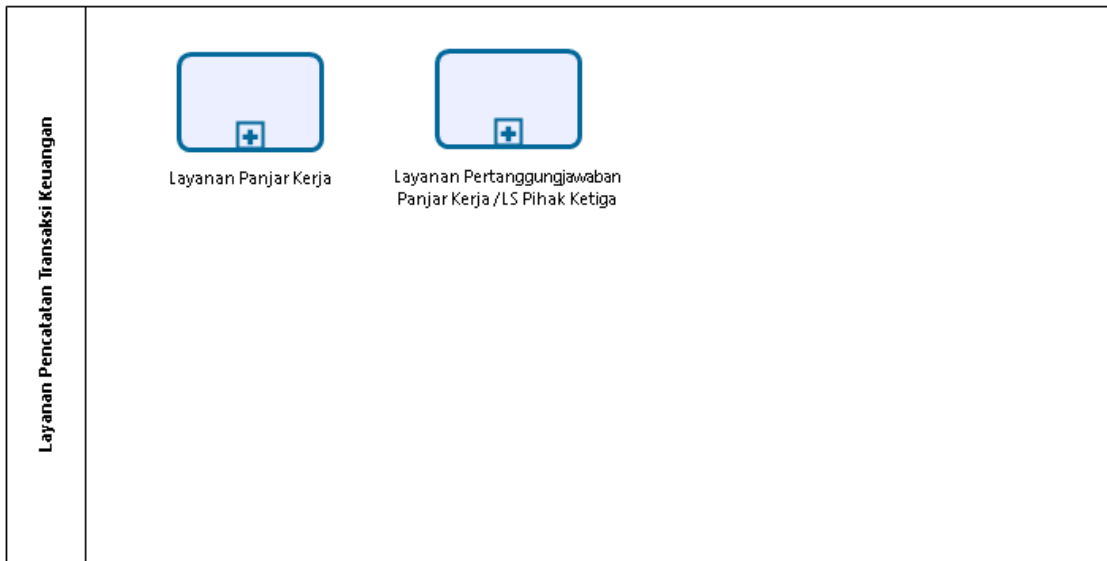

Powered by
bizagi
Modeler

Level 5 Layanan Panjar Kerja

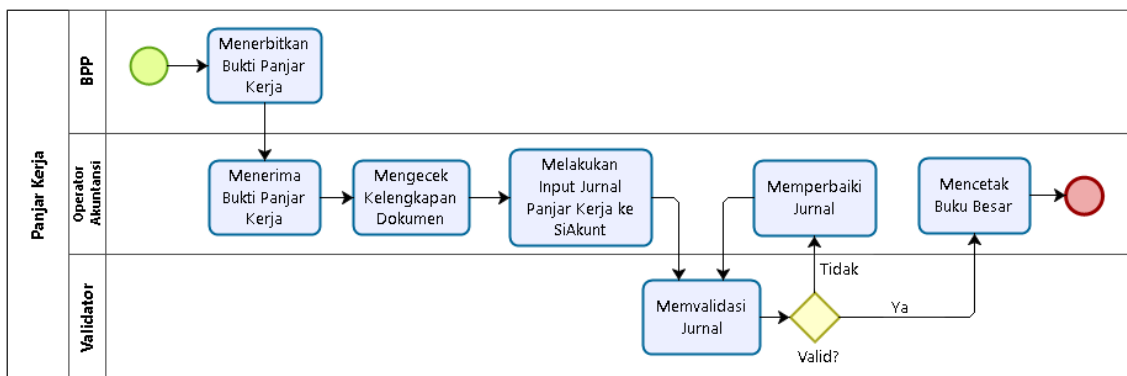

Powered by
bizagi
Modeler

Level 5 Layanan Pertanggungjawaban Panjar Kerja / LS Pihak Ketiga

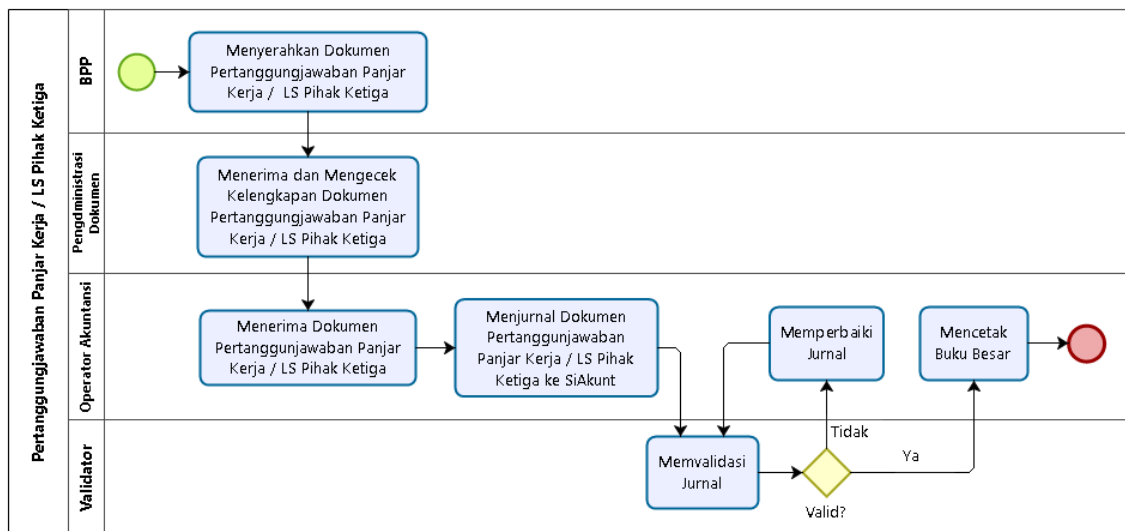

Powered by
bizagi
Modeler

Level 4 Layanan Pengajuan Usul Program / Kegiatan

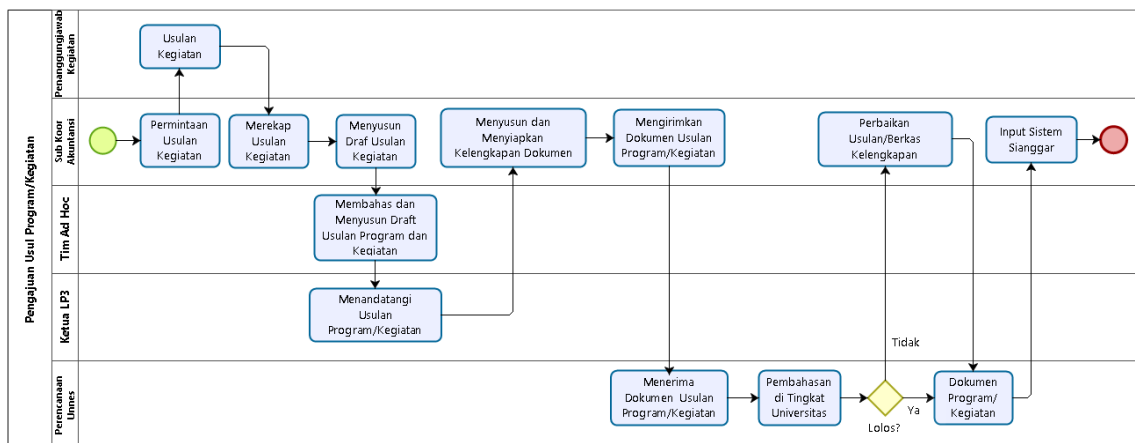

Powered by
bizagi
Modeler

Level 4 Layanan Penyusunan TRPNBP

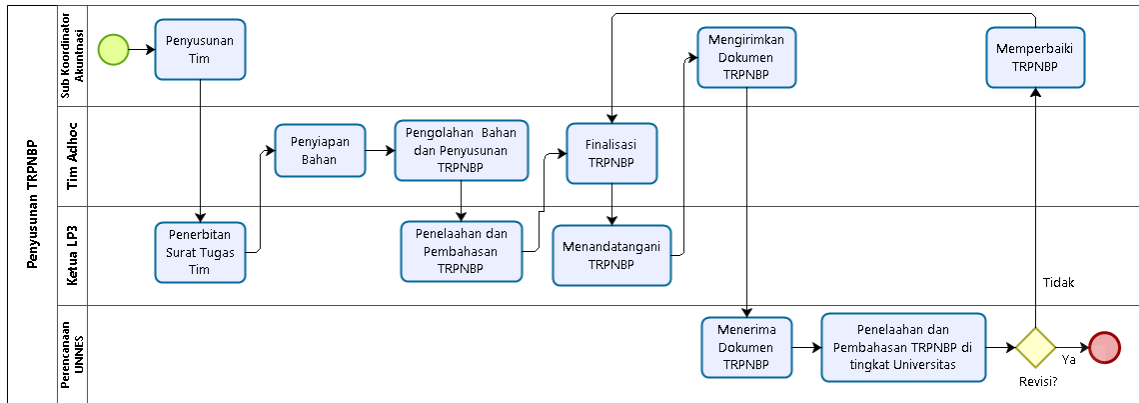

Powered by
bizagi
Modeler

Level 4 Layanan Penyusunan RBA

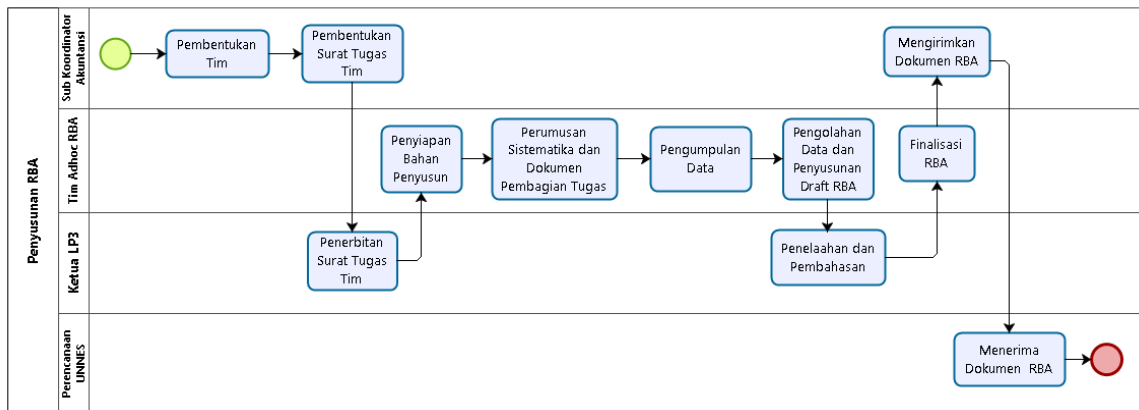

Powered by
bizagi
Modeler

Level 4 Layanan Penyusunan LAKUK

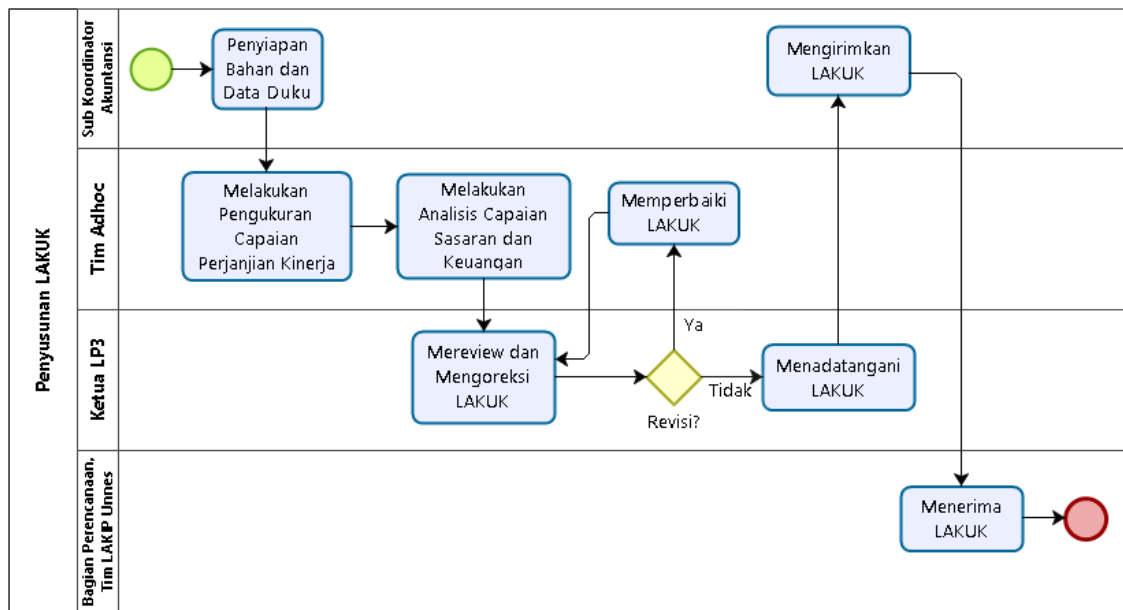

Powered by
bizagi
Modeler

Level 4 Layanan Revisi POK

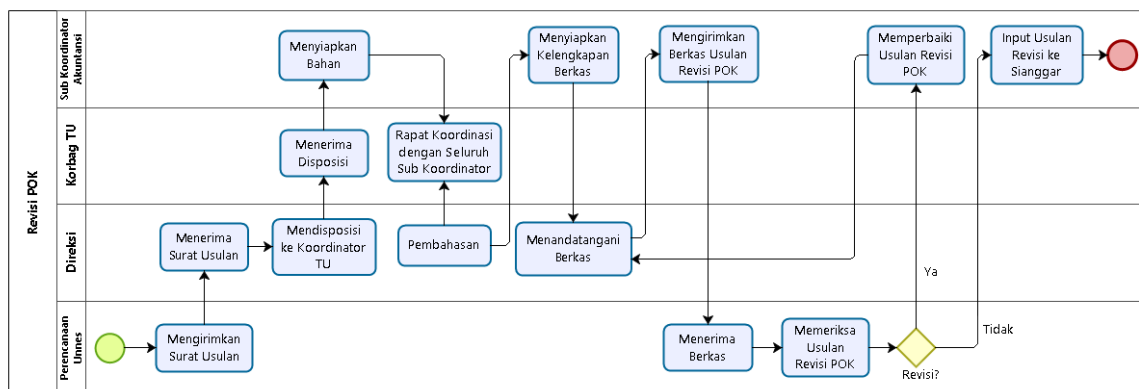

Powered by
bizagi
Modeler

Level 4 Layanan Monev Kinerja

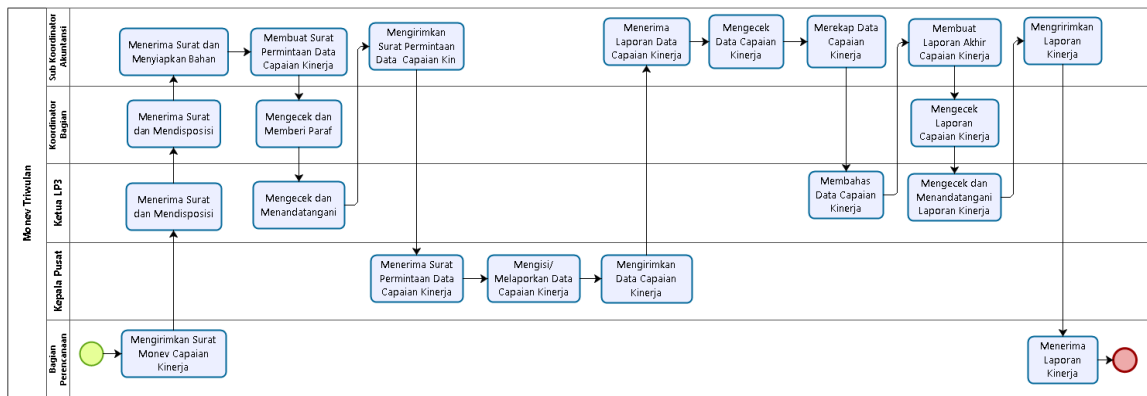

Level 3 Layanan Keuangan LP3

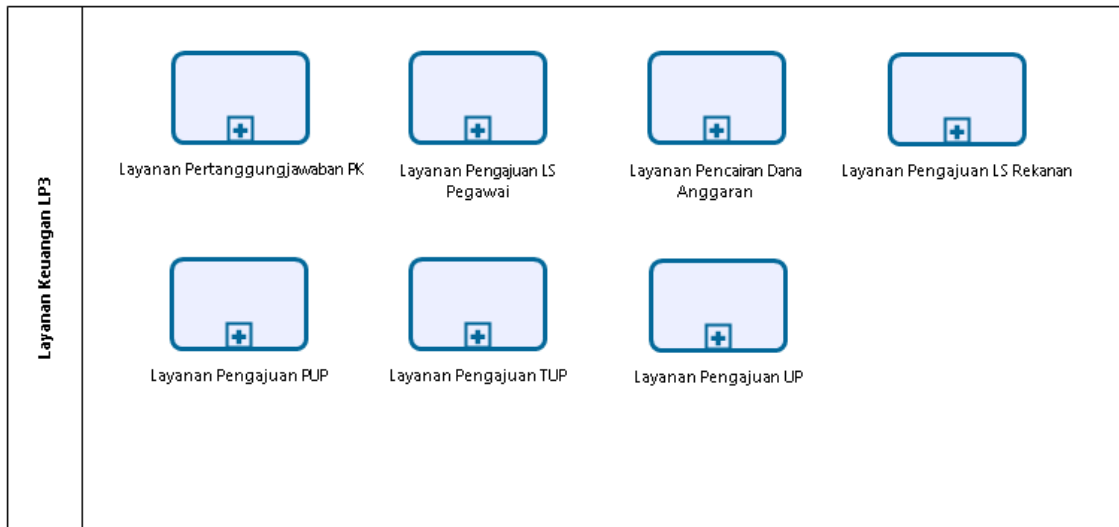

Powered by
bizagi
Modeler

Level 4 Layanan Pertanggungjawaban PK

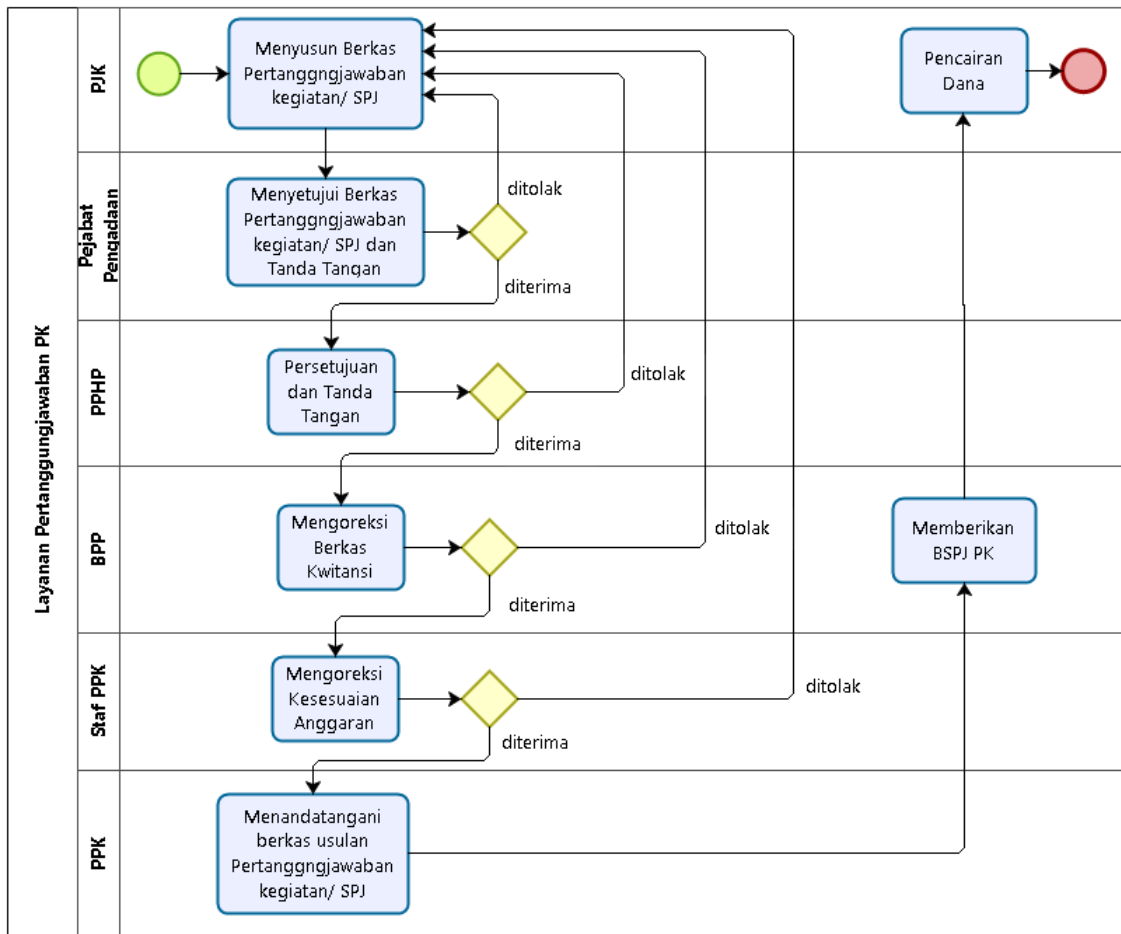

Level 4 Layanan Pengajuan LS Pegawai

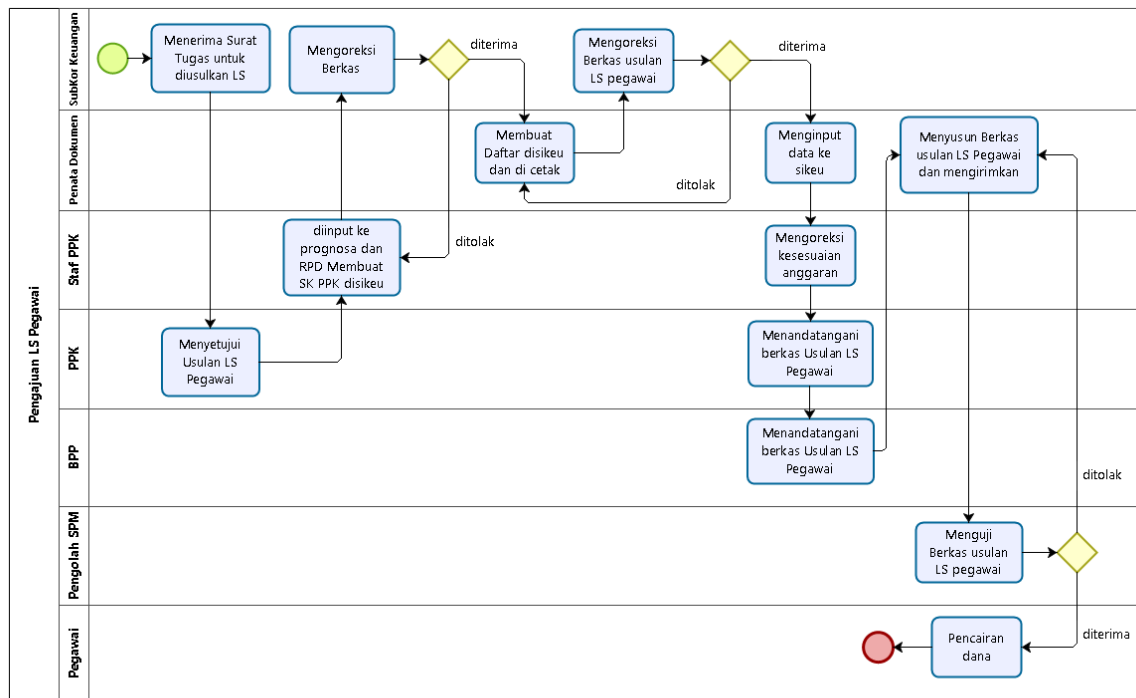

Level 4 Layanan Pencairan Dana Anggaran

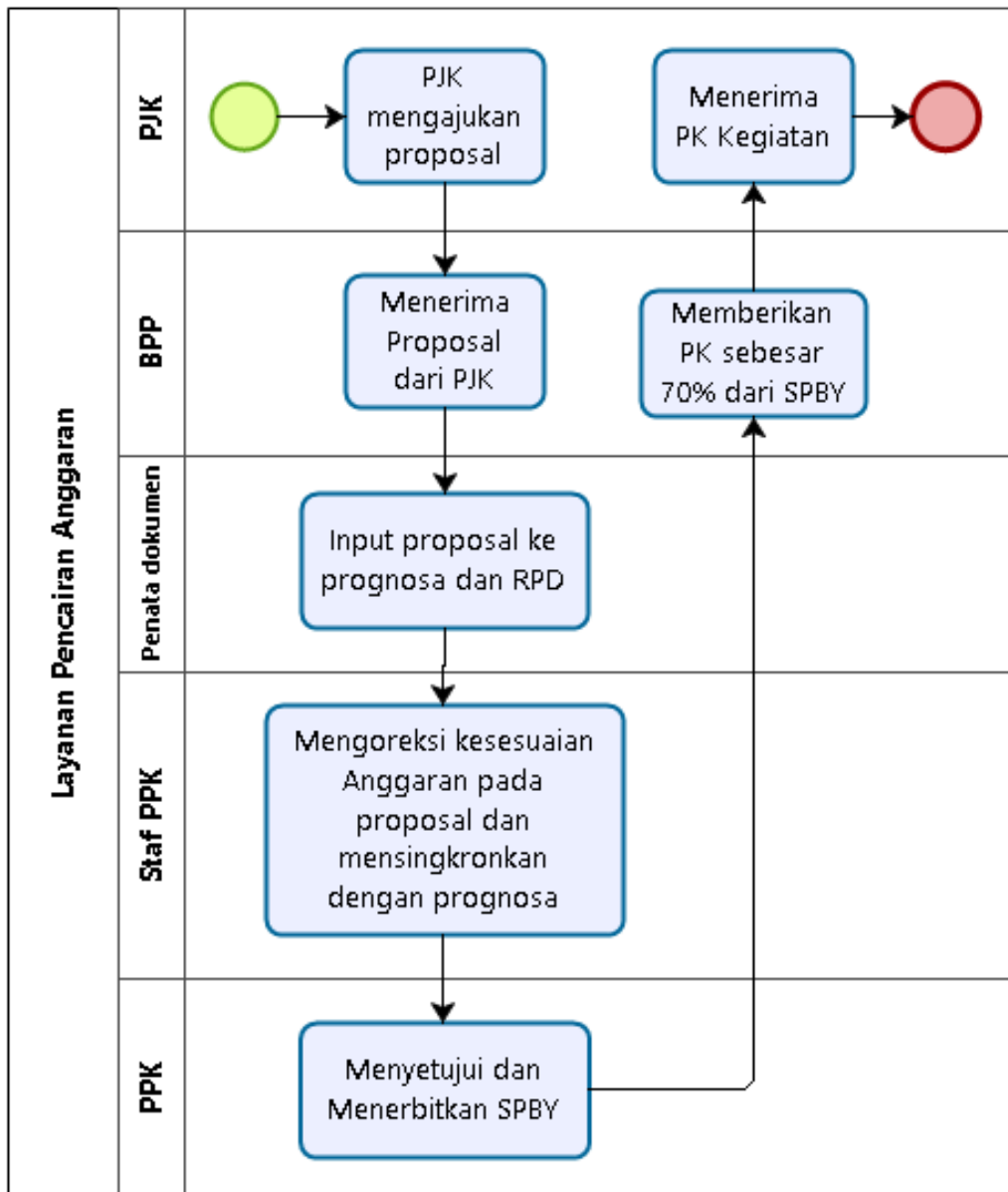

Level 4 Layanan Pengajuan LS Rekanan

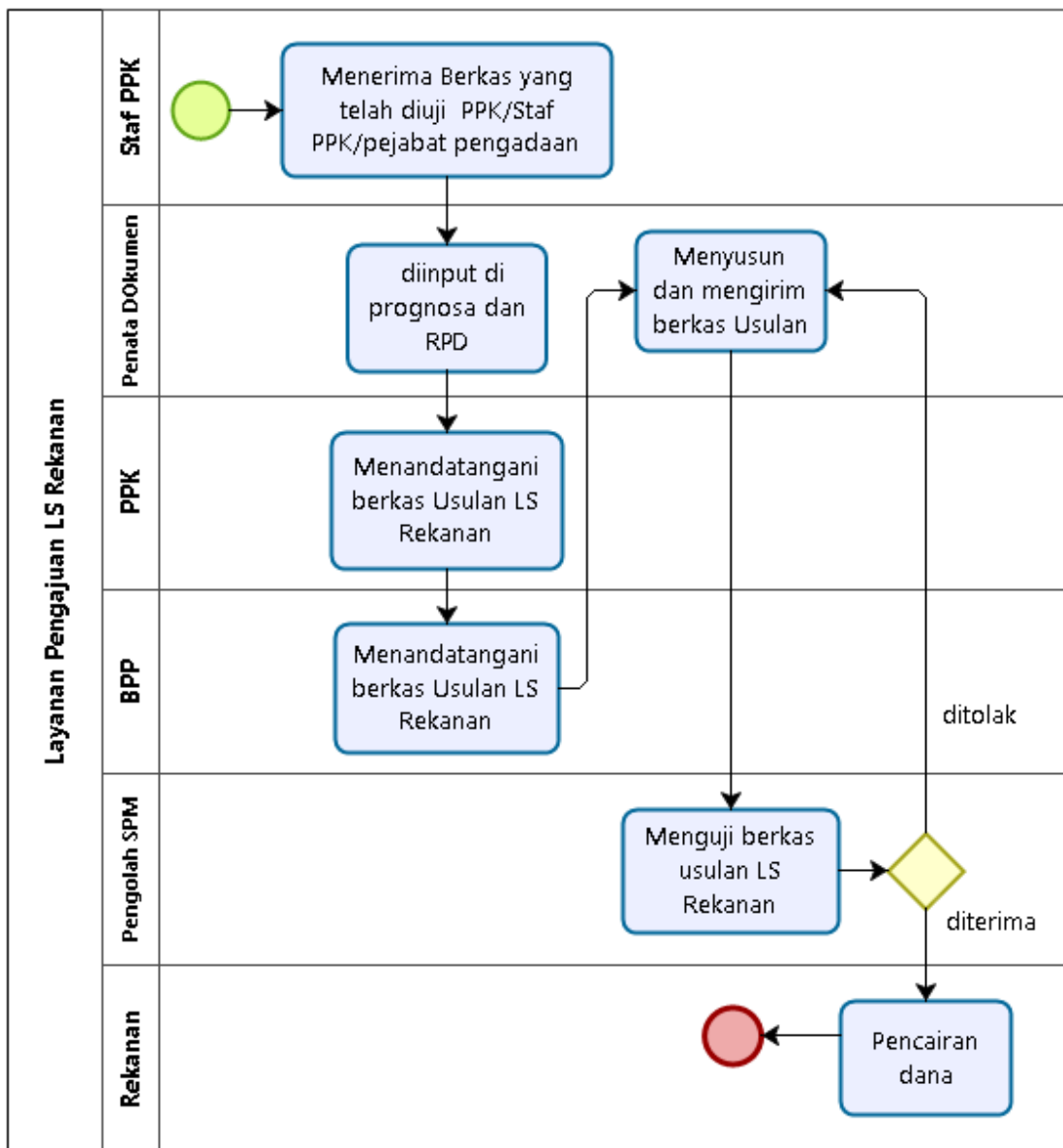

Level 4 Layanan Pengajuan PUP

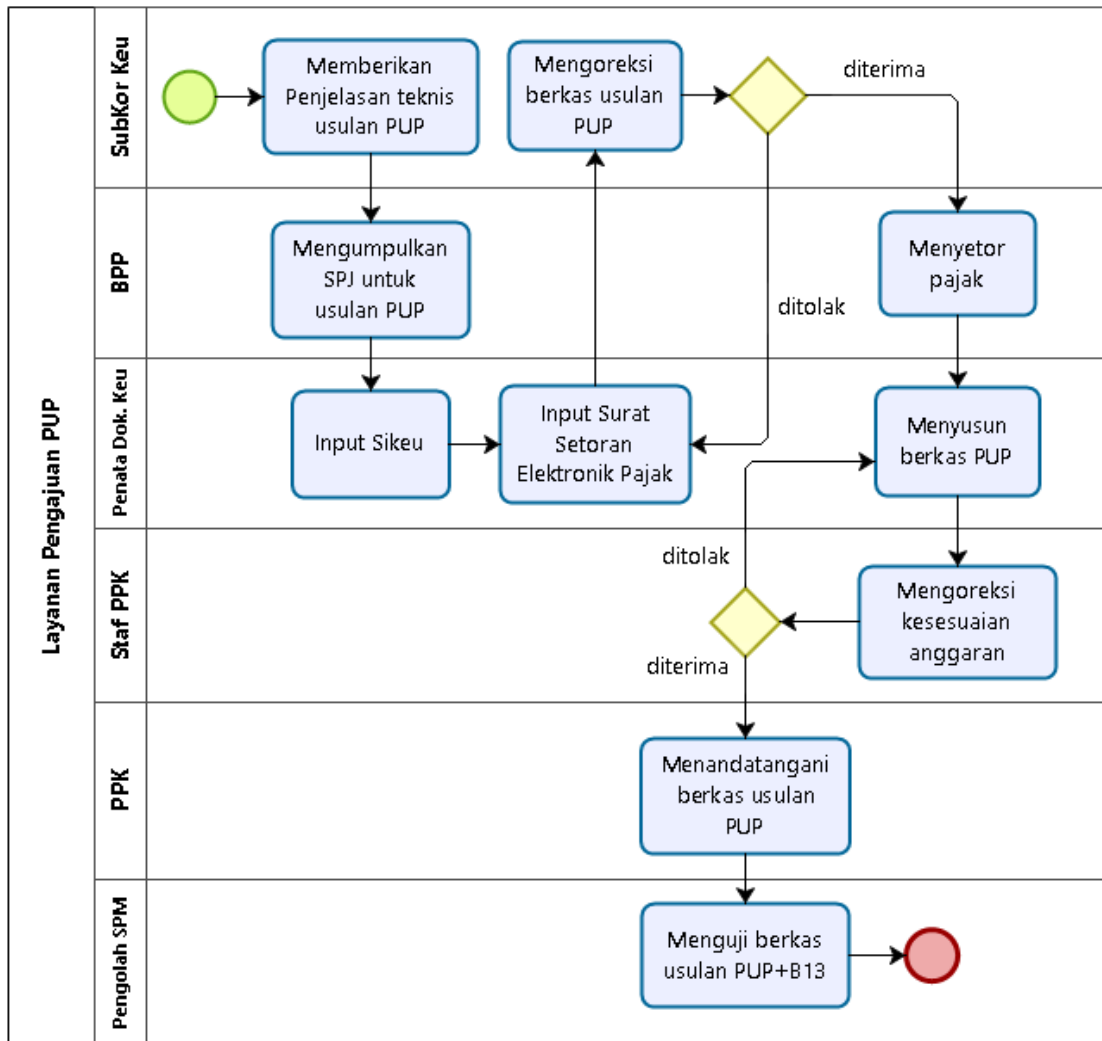

Level 4 Layanan Pengajuan TUP

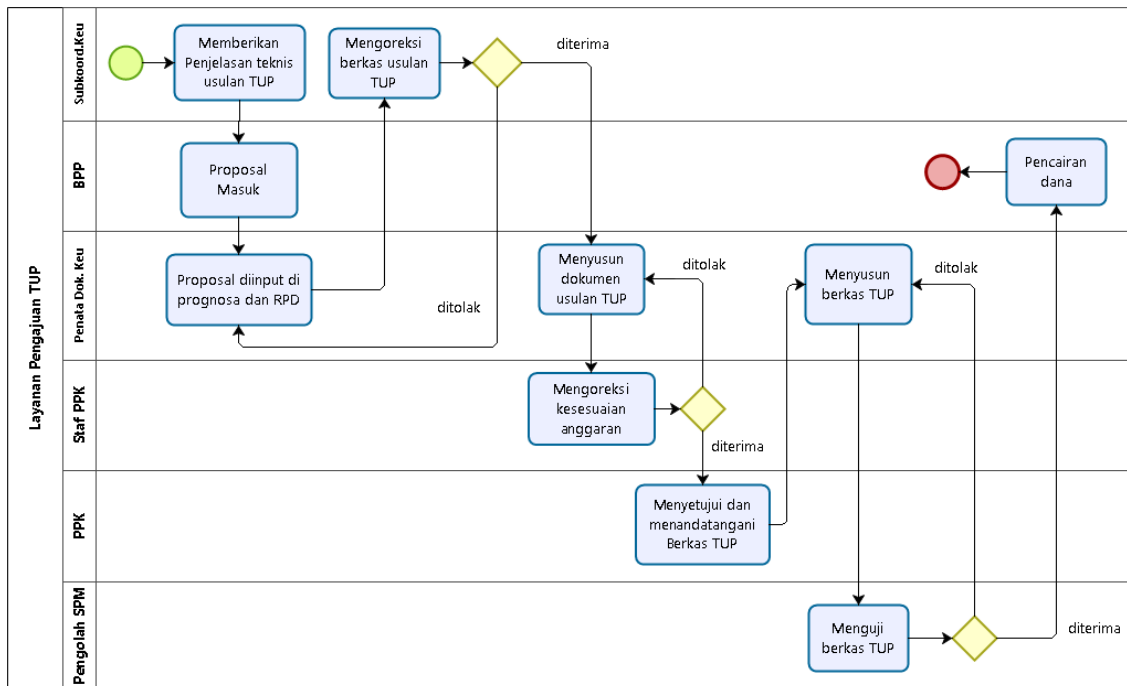

Level 4 Layanan Pengajuan UP

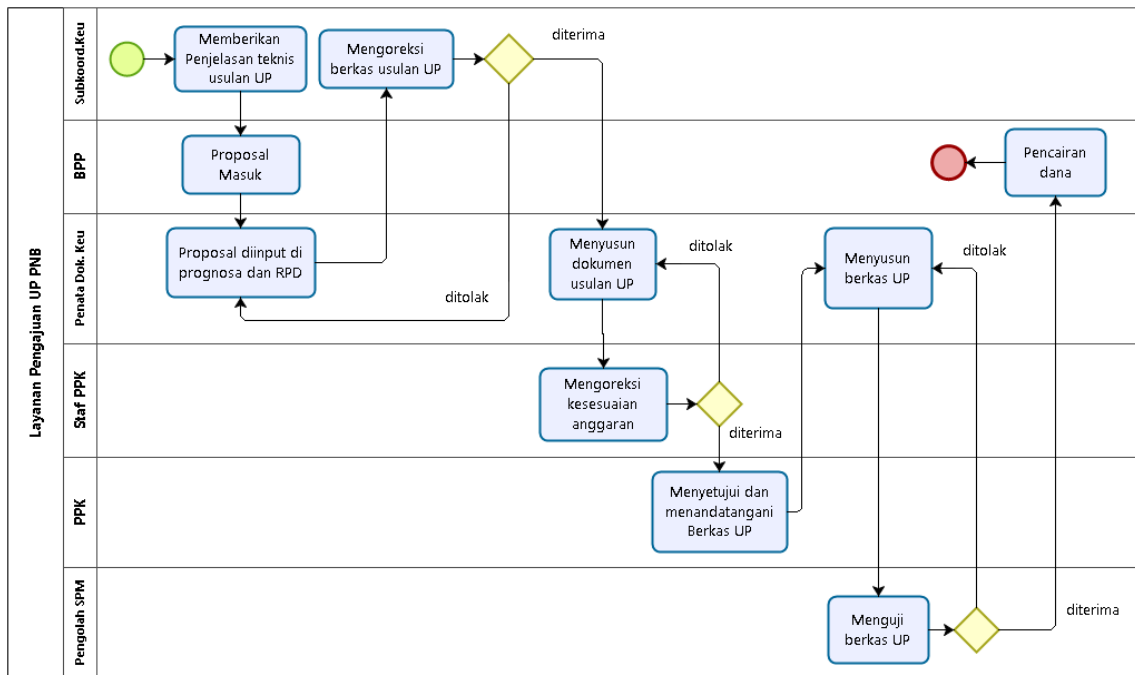

Powered by
bizagi
Modeler

Level 3 Layanan Umum LP3

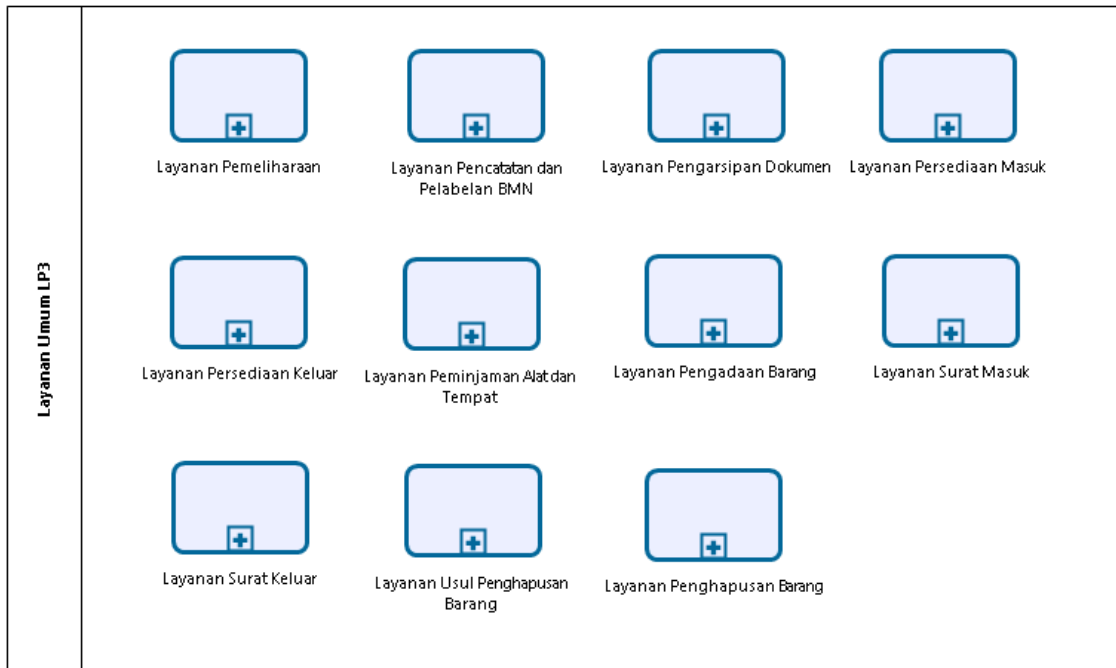

Level 4 Layanan Pemeliharaan

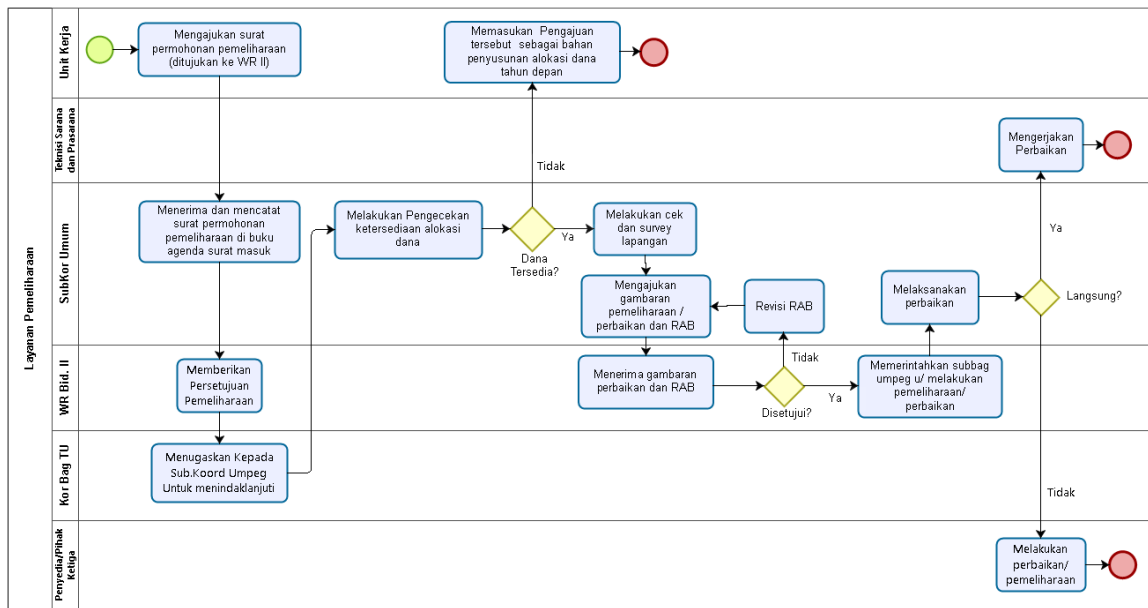

Level 4 Layanan Pencatatan dan Pelabelan BMN

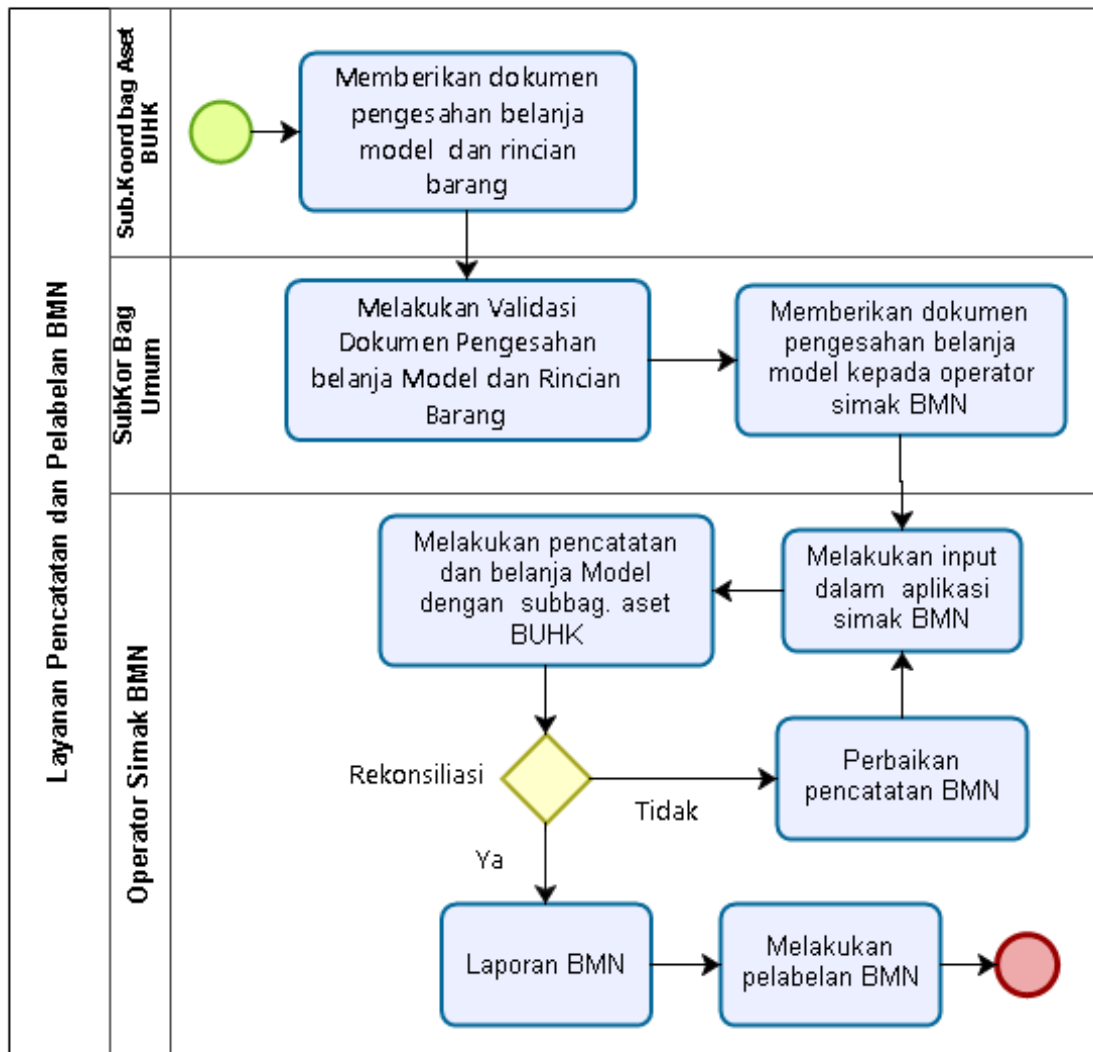

Level 4 Layanan Pengarsipan Dokumen

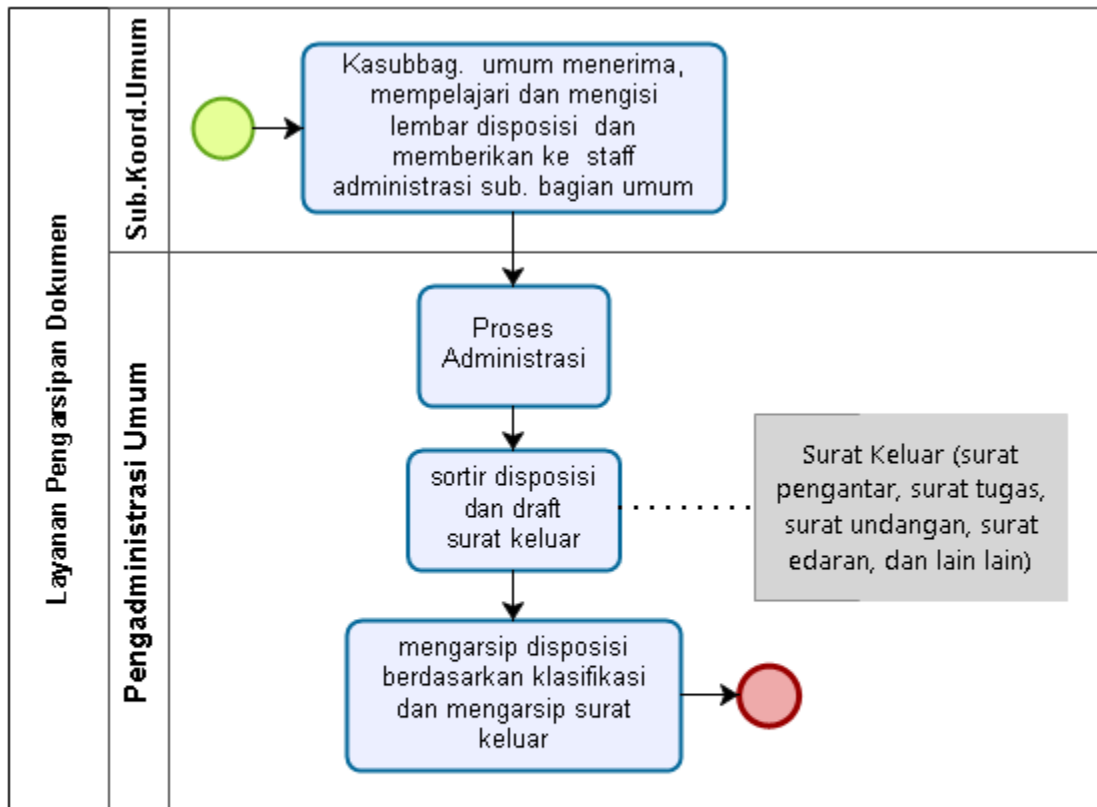

Level 4 Layanan Persediaan Masuk

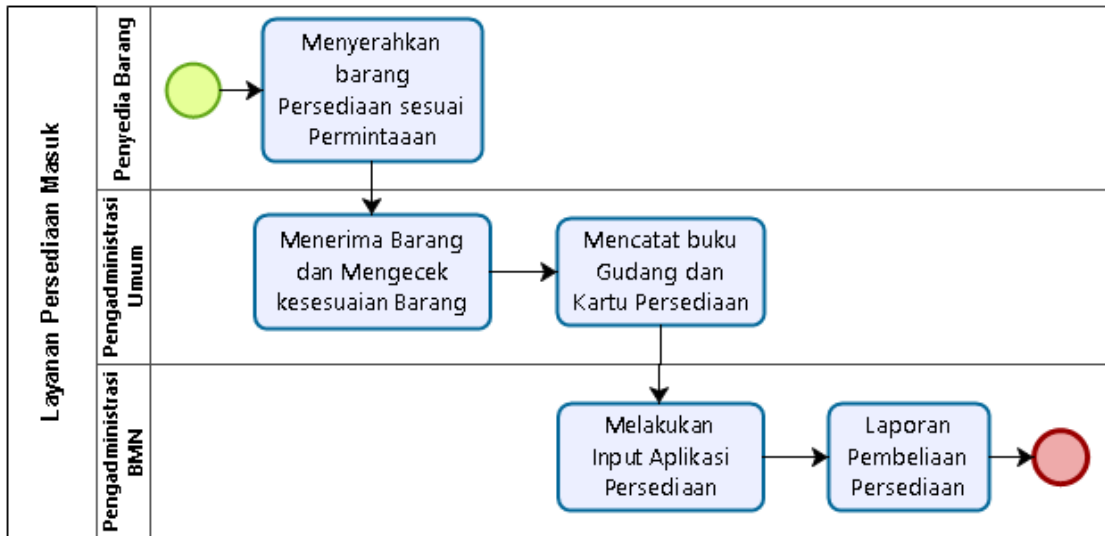

Level 4 Layanan Persediaan Keluar

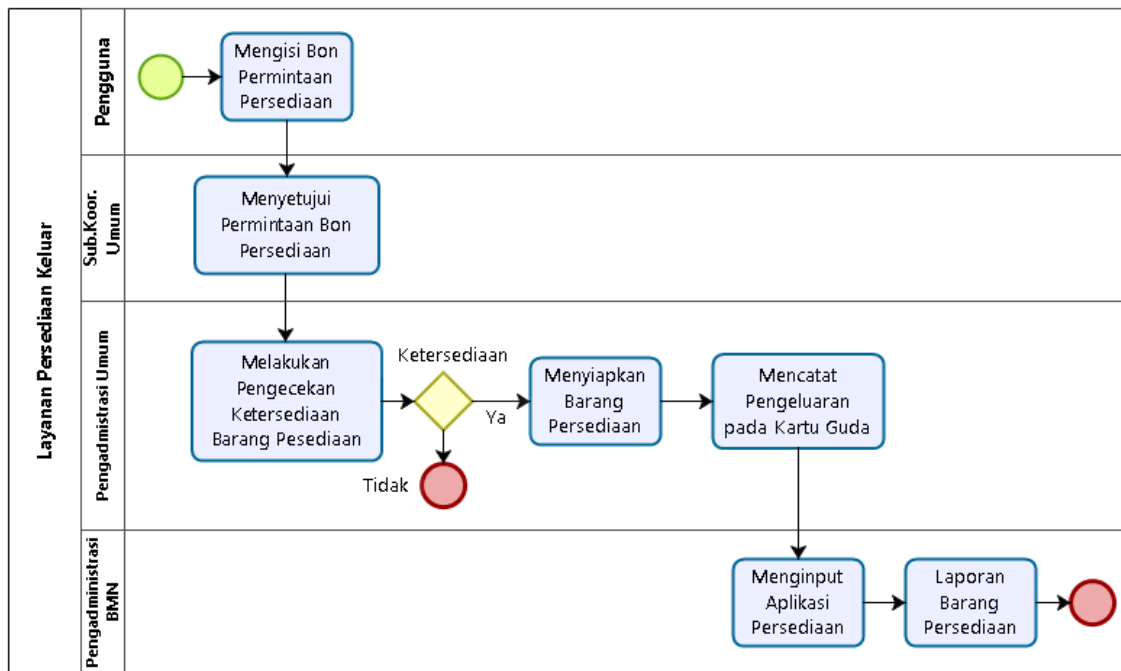

Level 4 Layanan Peminjaman Alat dan Tempat

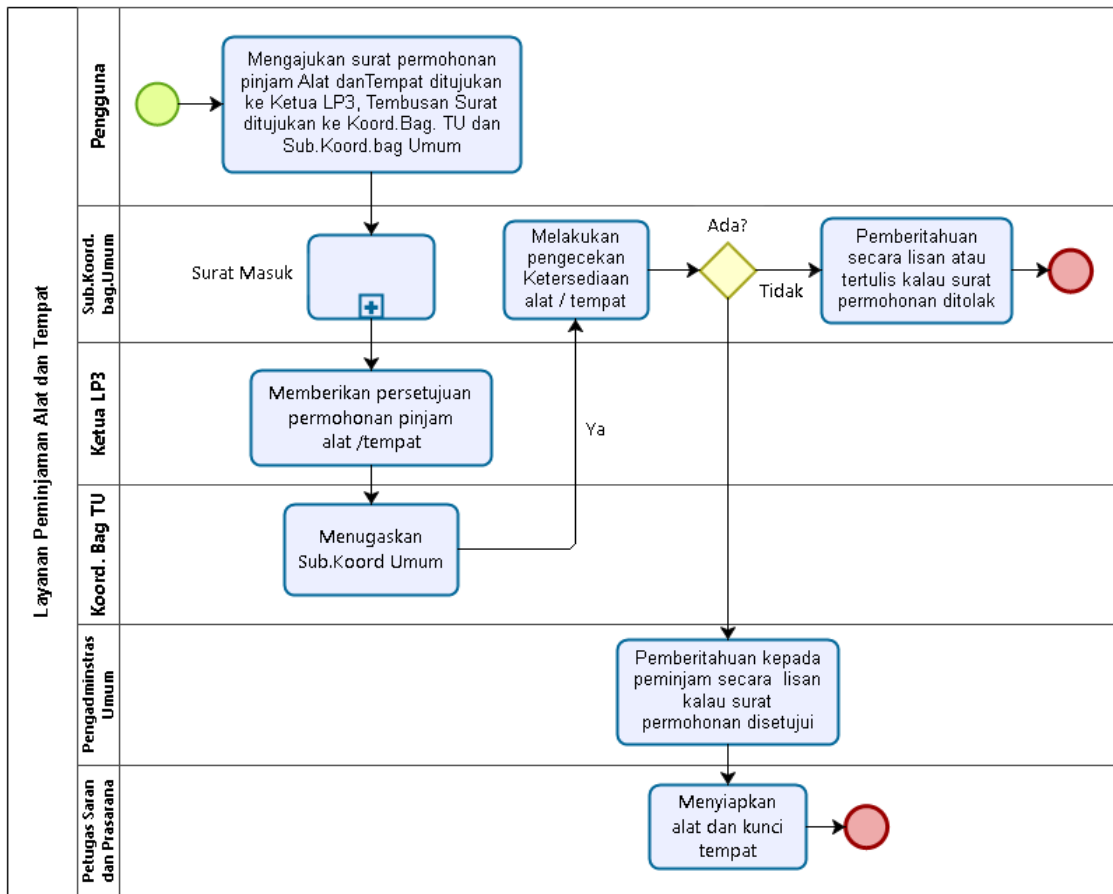

Level 4 Layanan Pengadaan Barang

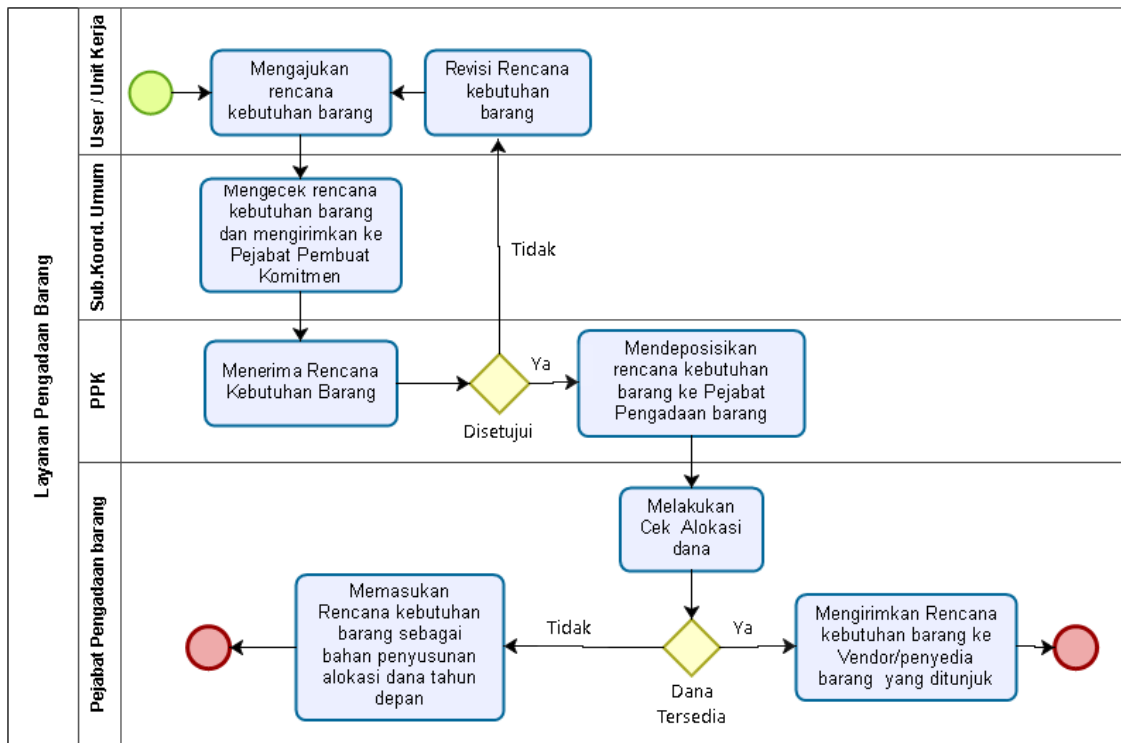

Level 4 Layanan Surat Masuk LP3

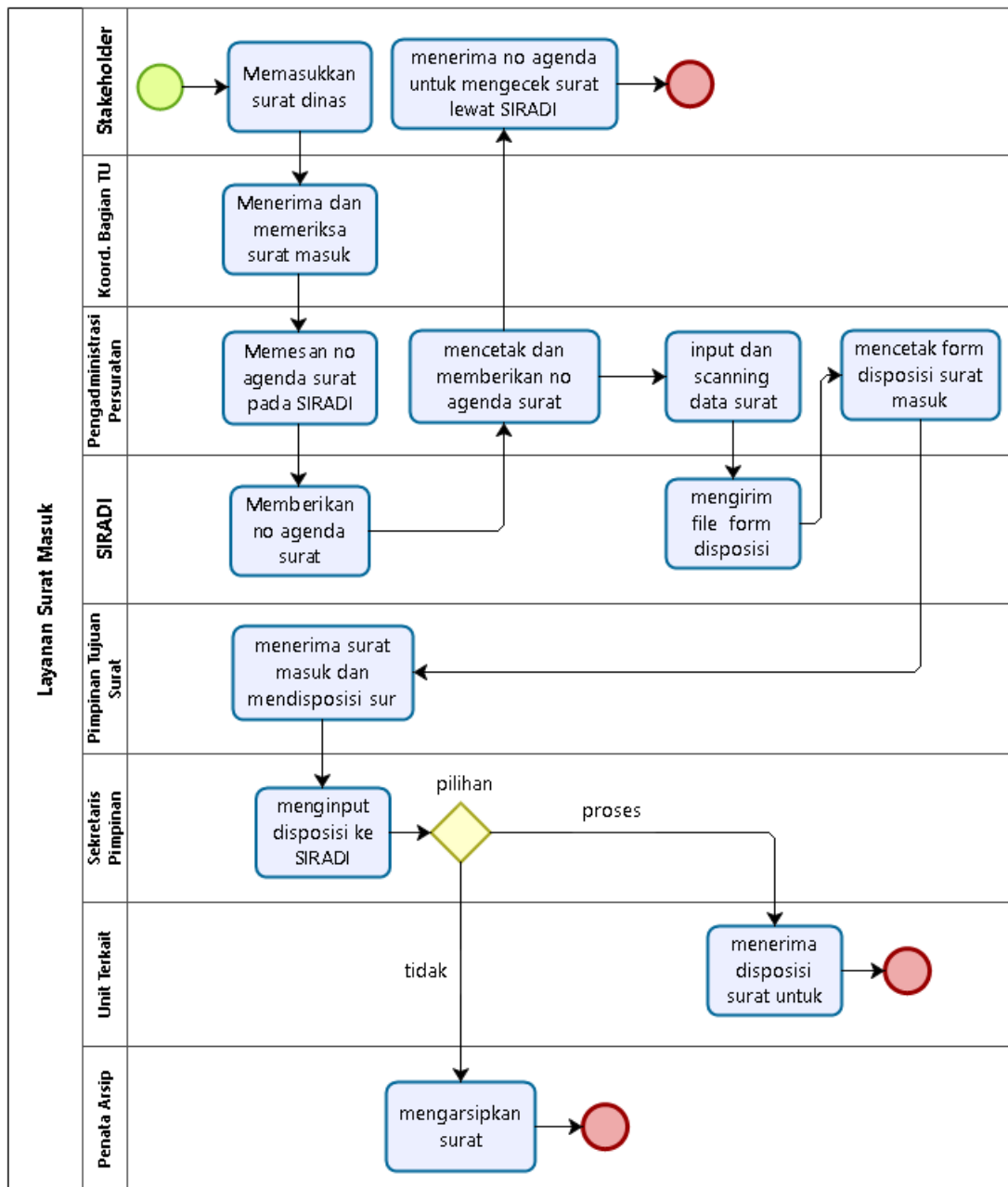

Level 4 Layanan Surat Keluar LP3

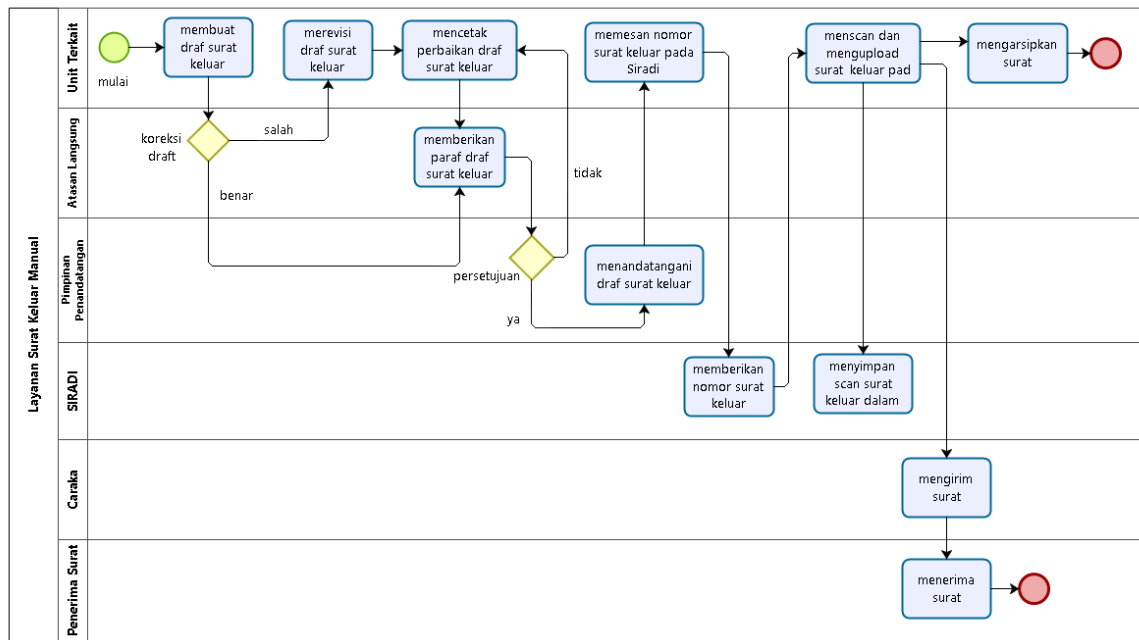

Level 4 Layanan Usul Penghapusan Barang

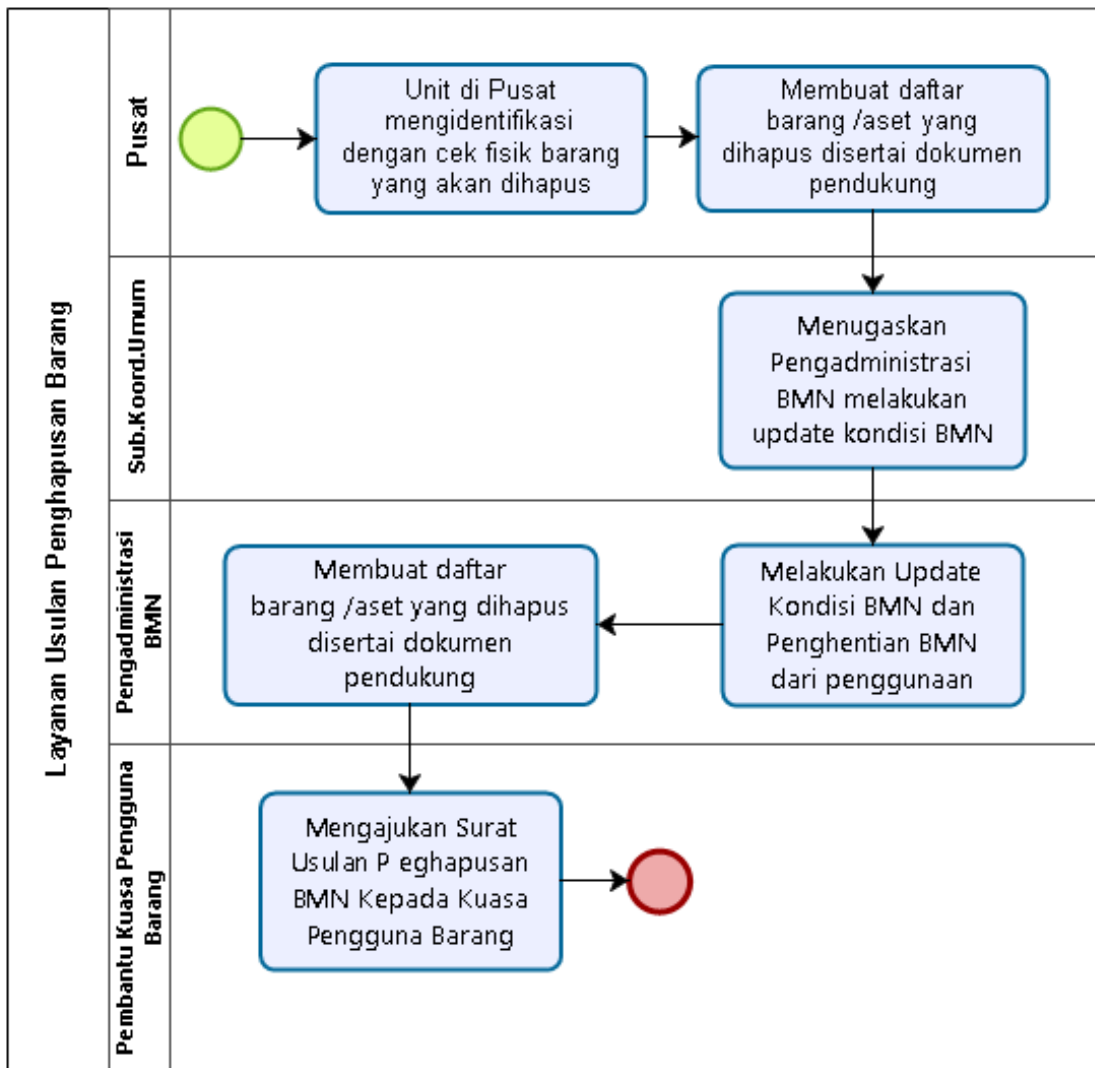

Level 4 Layanan Penghapusan Barang

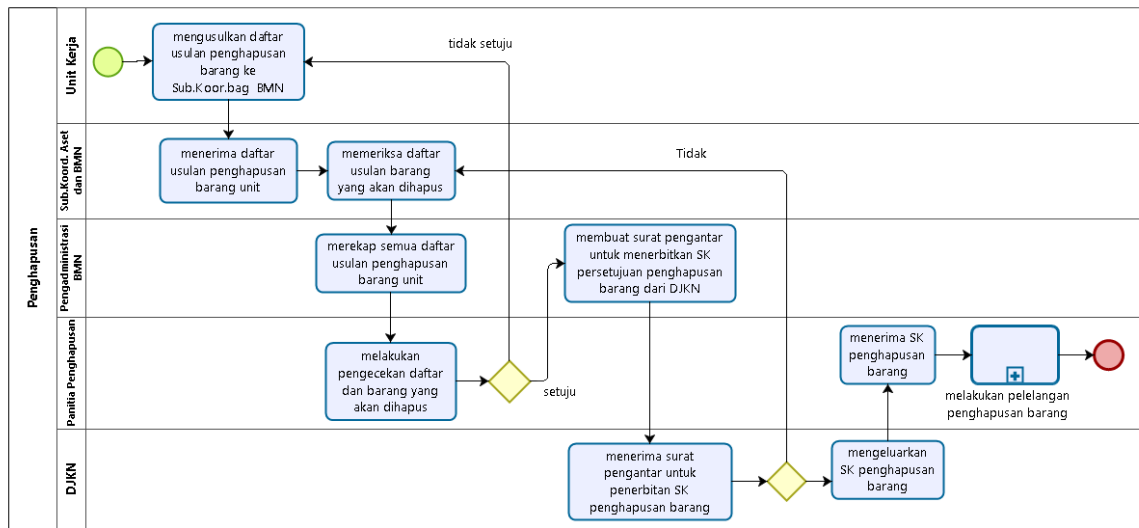

Powered by
bizagi
Modeler

Level 2 Layanan LPPM

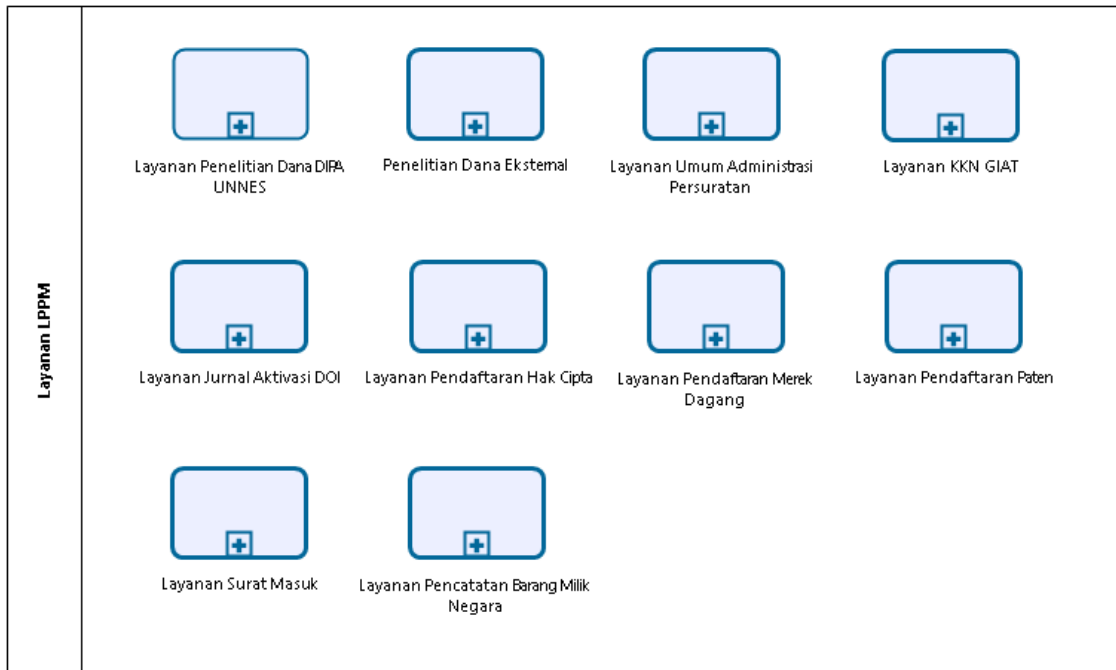

Level 3 Layanan Penelitian Dana Eksternal

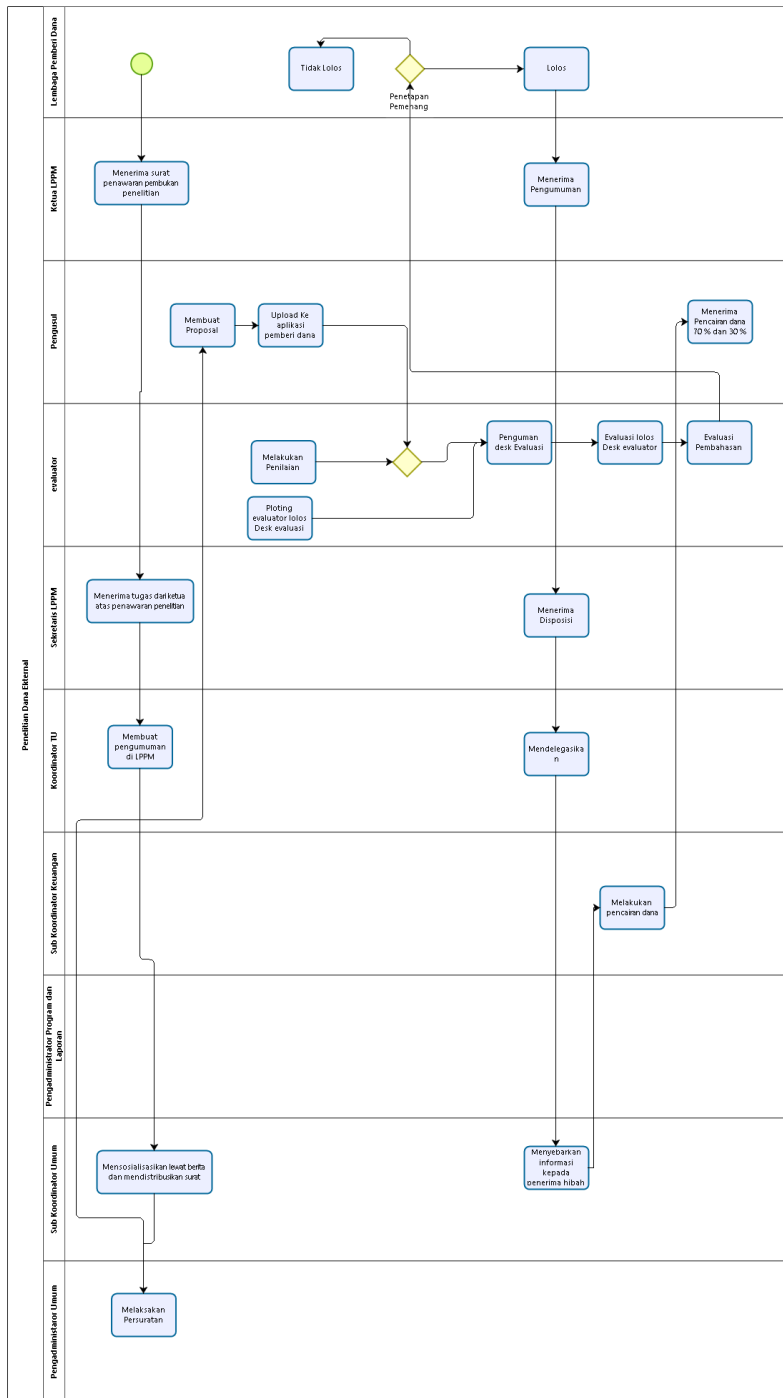

Level 3 Layanan Jurnal Aktivasi DOI

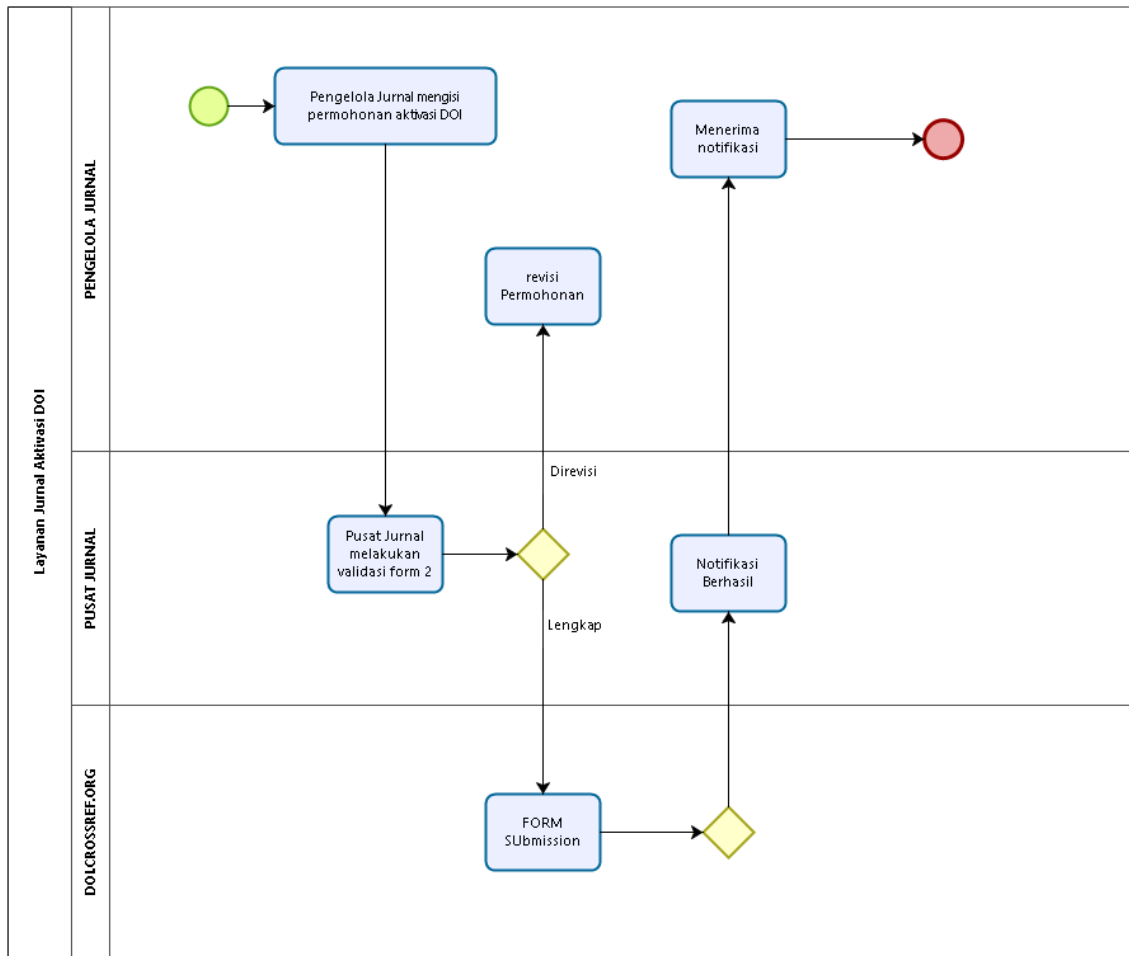

Level 3 Layanan Pendaftaran Hak Cipta

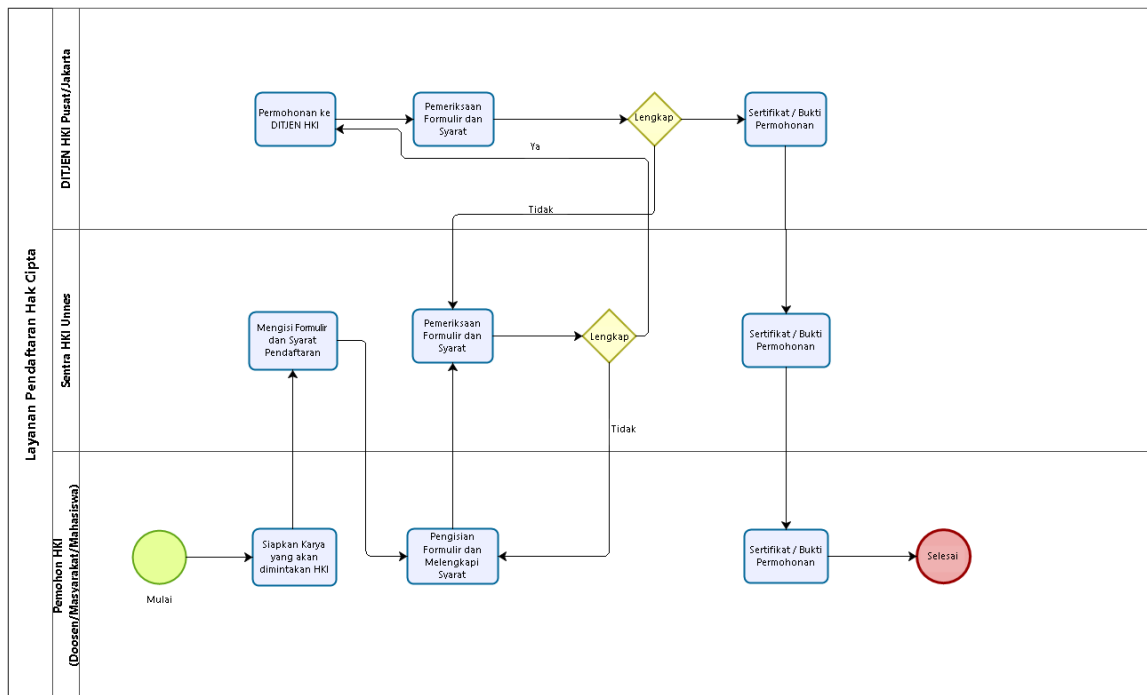

Level 3 Layanan Pendaftaran Merek Dagang

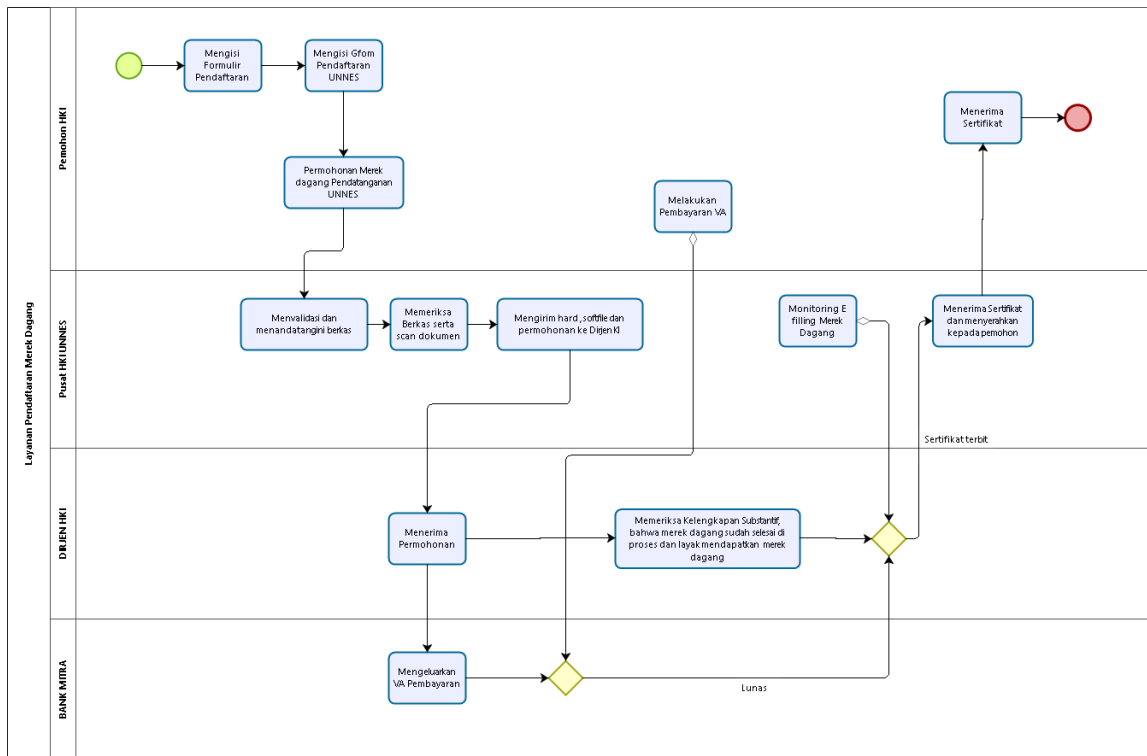

Level 3 Layanan Pendaftaran Paten

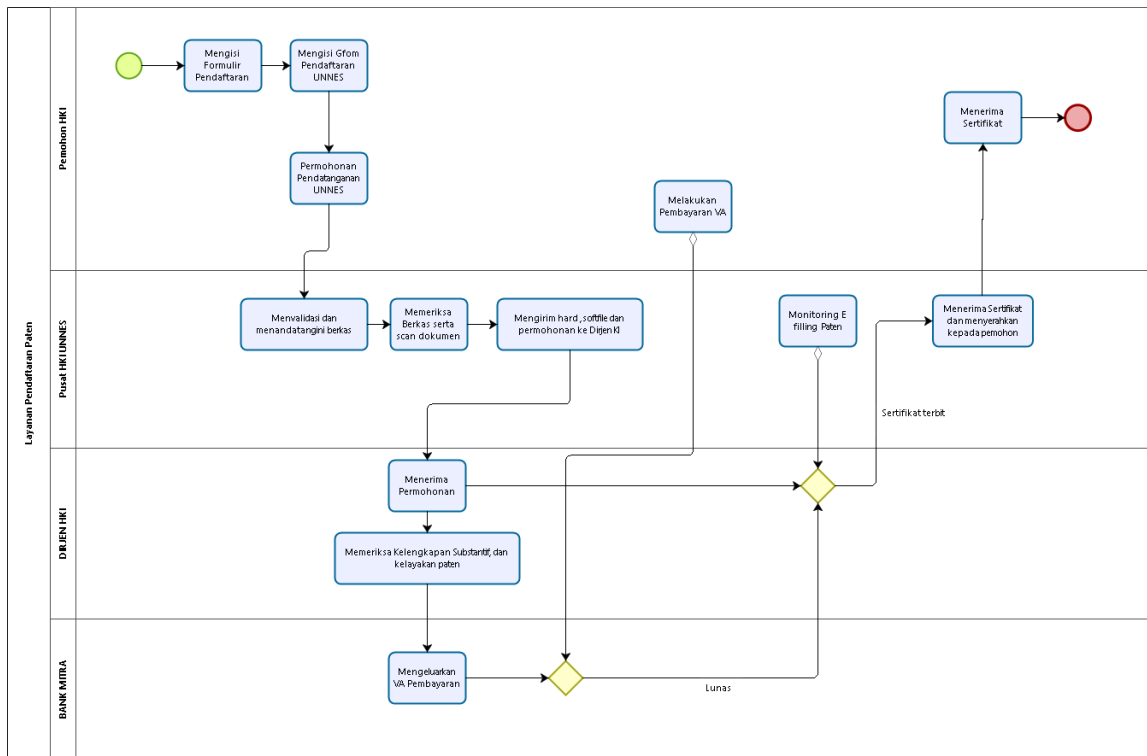



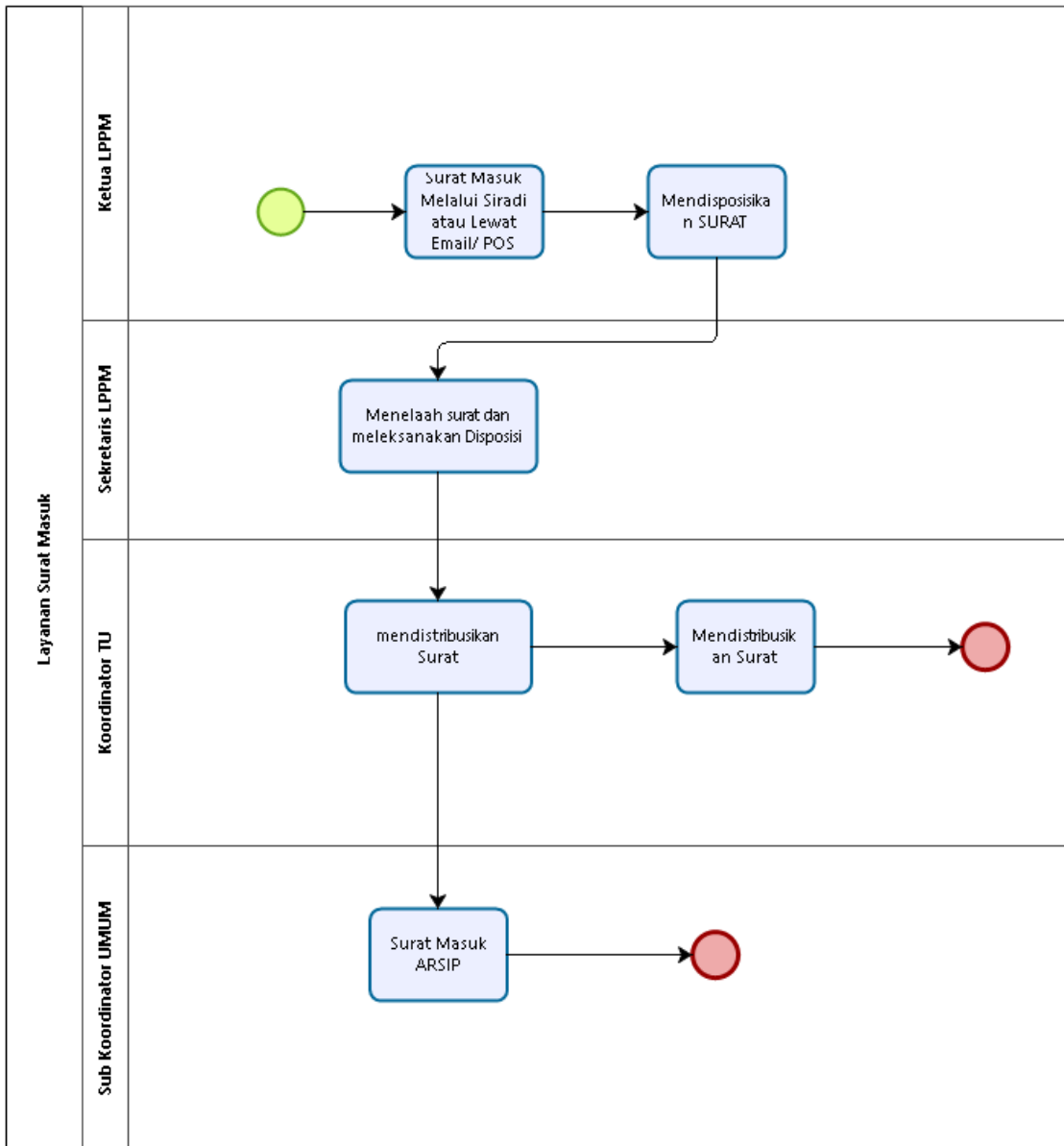



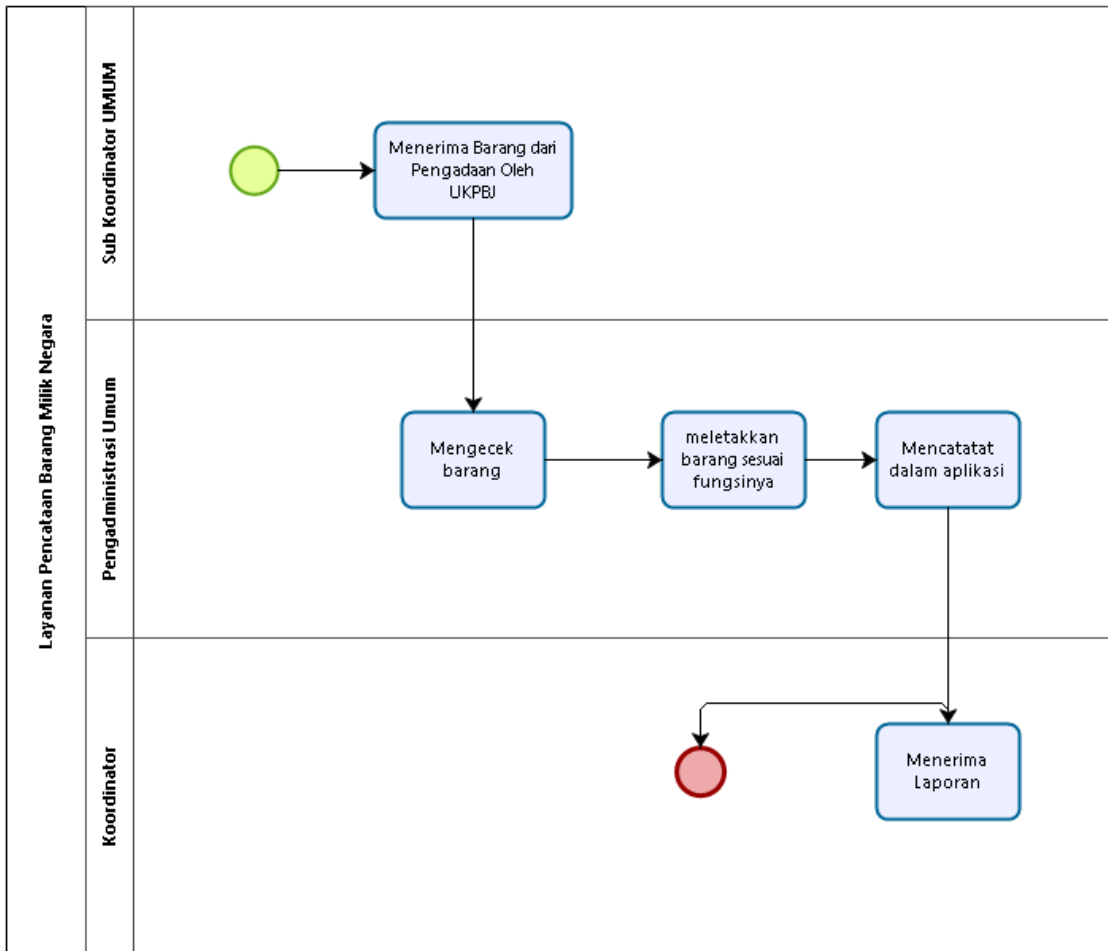









Level 3 Layanan Surat Masuk LPPM



Level 3 Layanan Pencatatan Barang Milik Negara



Level 1 Layanan Penjaminan Mutu

Layanan Badan Penjaminan Mutu	Layanan Pendampingan dan Review Internal Penyusunan Anggaran	 <p>Layanan Konversi status akreditasi Prodi dan Inibusi</p>	 <p>Layanan Pengurusan Prodi Baru</p>	 <p>Layanan Proses Akreditasi Prodi BAN-PT</p>	 <p>Layanan Proses akreditasi Prodi LAMEDIK</p>	 <p>Layanan Proses akreditasi Prodi LAMTEKNIK</p>	
	Layanan Pendampingan dan Review Internal Penyusunan Anggaran	 <p>Layanan Proses akreditasi Prodi LAMSAMA</p>	 <p>Layanan Proses akreditasi Prodi LAMINFOKOM</p>	 <p>Layanan Proses akreditasi Prodi LAMPTKES</p>	 <p>Layanan Proses akreditasi Prodi LAMEMBA</p>		
	Layanan Keperluan Pokok	 <p>Layanan Pemenuhan Kebutuhan Pokok dan Fasilitas UK</p>					
	Layanan Gaji dan Tunjangan Tenaga Kependidikan Non PNS	 <p>Layanan Pembayaran Gaji Tenaga Kependidikan Kontrak PKK</p>					
	Layanan Audit Mutu Akademik	 <p>Layanan Audit Mutu Internal (AMI)</p>					
	Layanan Monitoring Pelaksanaan Penjaminan Mutu Akademik	 <p>Layanan Movev Awal Perkuliahan</p>					
Layanan FGD Penyusunan Dokumen Kebijakan Non Akademik	Layanan Audit Surveillance ISO	 <p>Layanan Audit Surveillance ISO</p>					
Layanan FGD Penyusunan Dokumen Kebijakan Non Akademik	 <p>Layanan Penerimaan Studi Banding Penjaminan Mutu</p>						
Layanan FGD Penyusunan Dokumen Kebijakan Non Akademik	 <p>Layanan Pengelolaan PDDIKTI</p>						

Level 2 Layanan Konversi Status Akreditasi Prodi dan Institusi

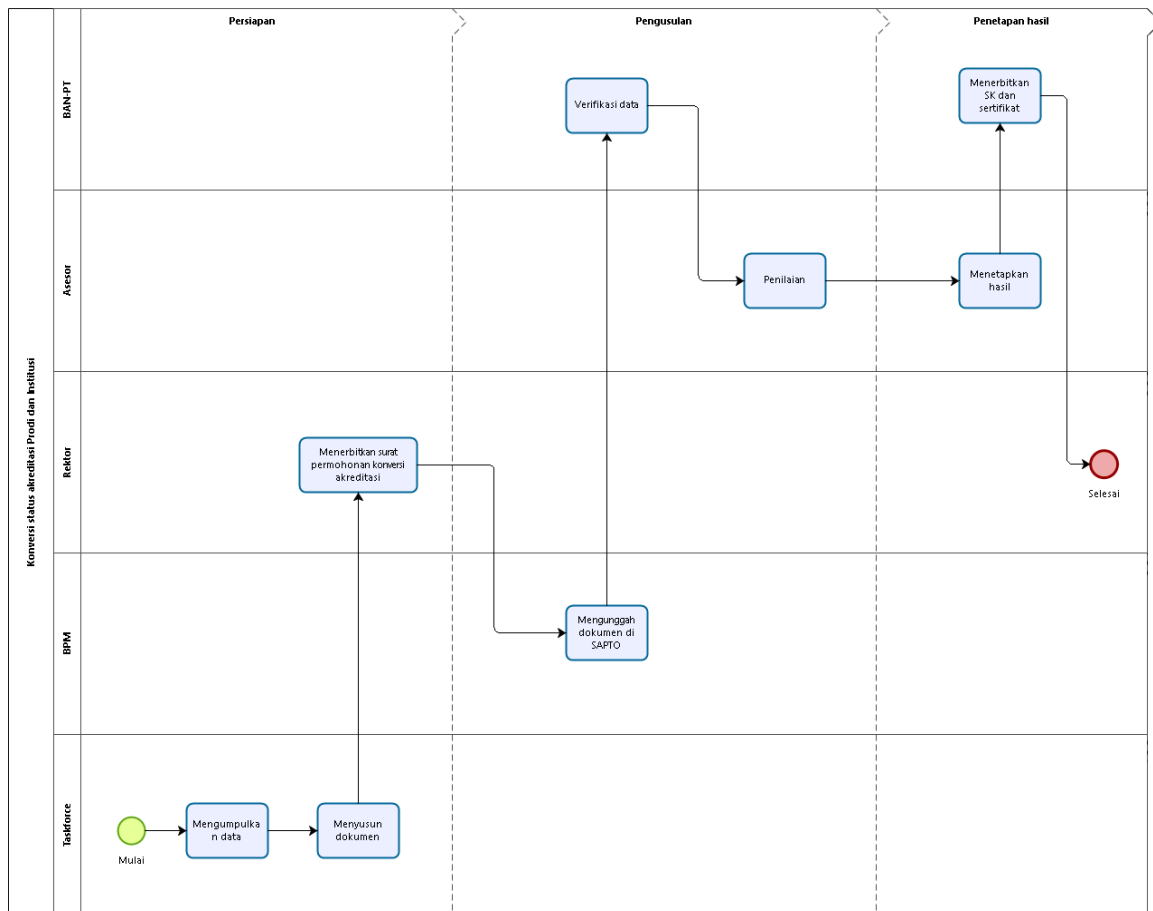

Level 2 Layanan Pengusulan Prodi Baru

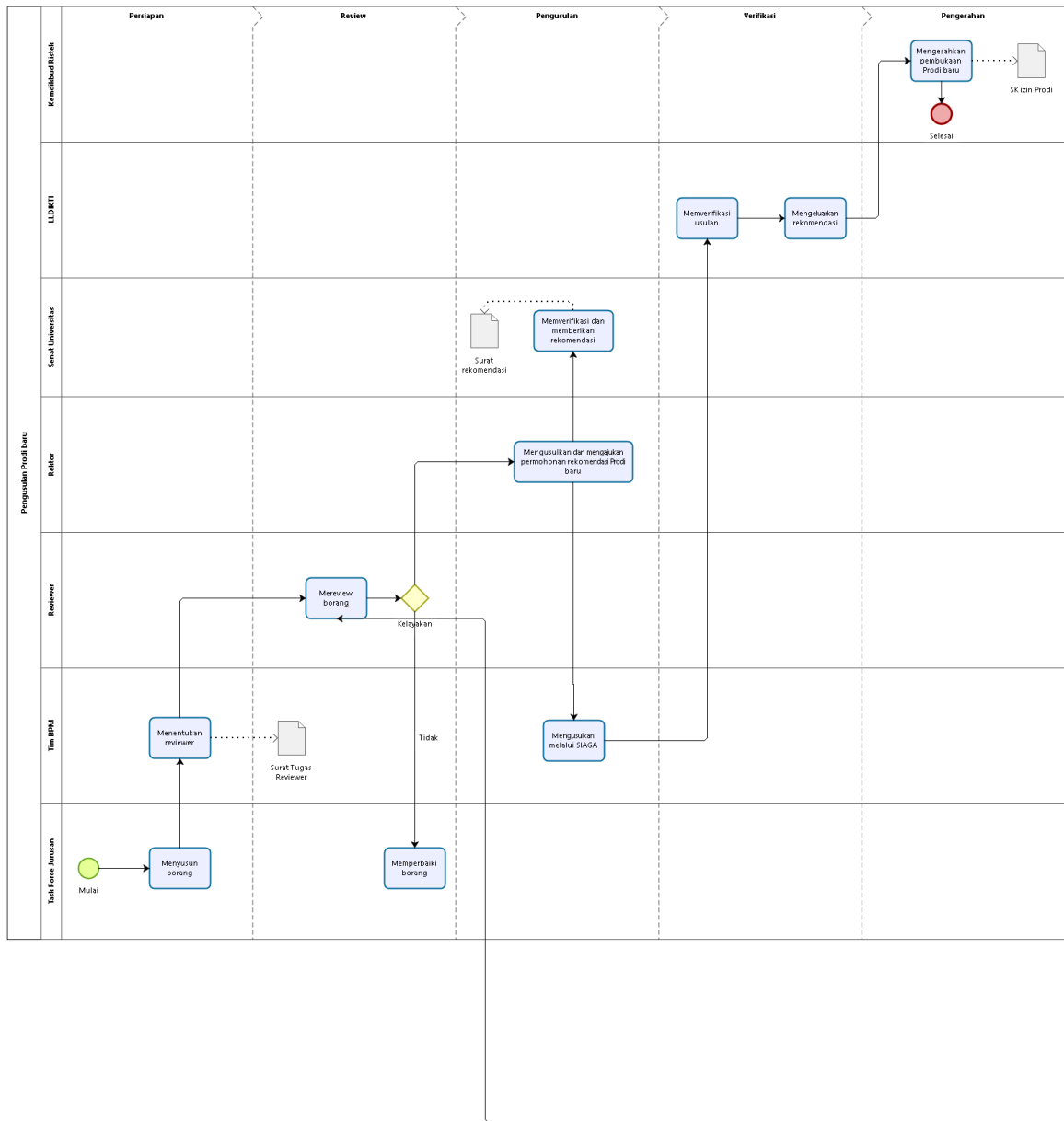

Level 2 Layanan Proses Akreditasi Prodi BAN-PT

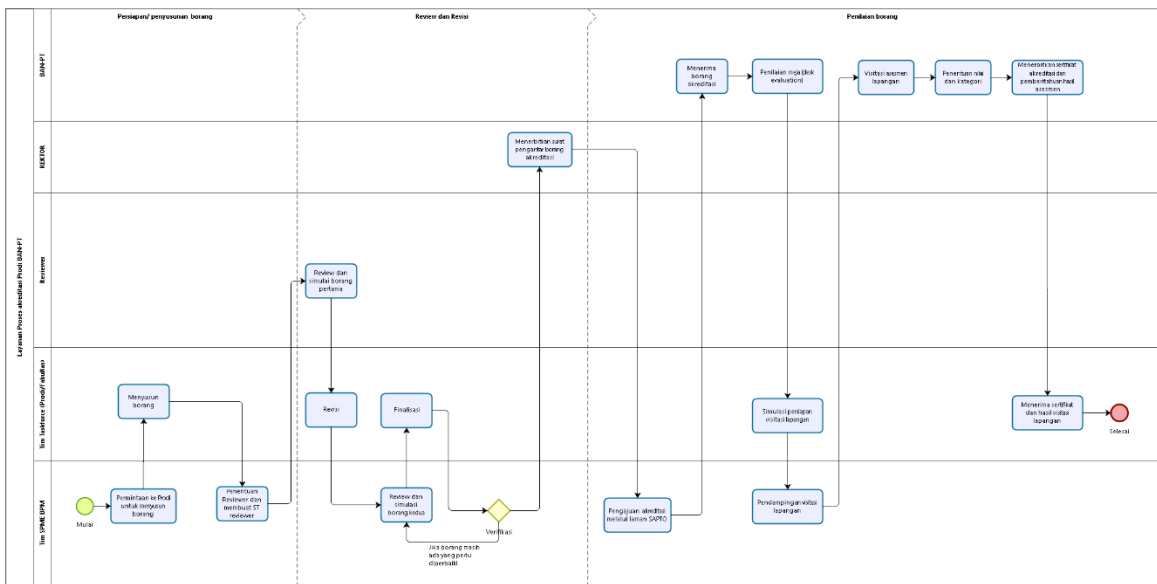

Level 2 Layanan Proses Akreditasi Prodi LAMPTKES

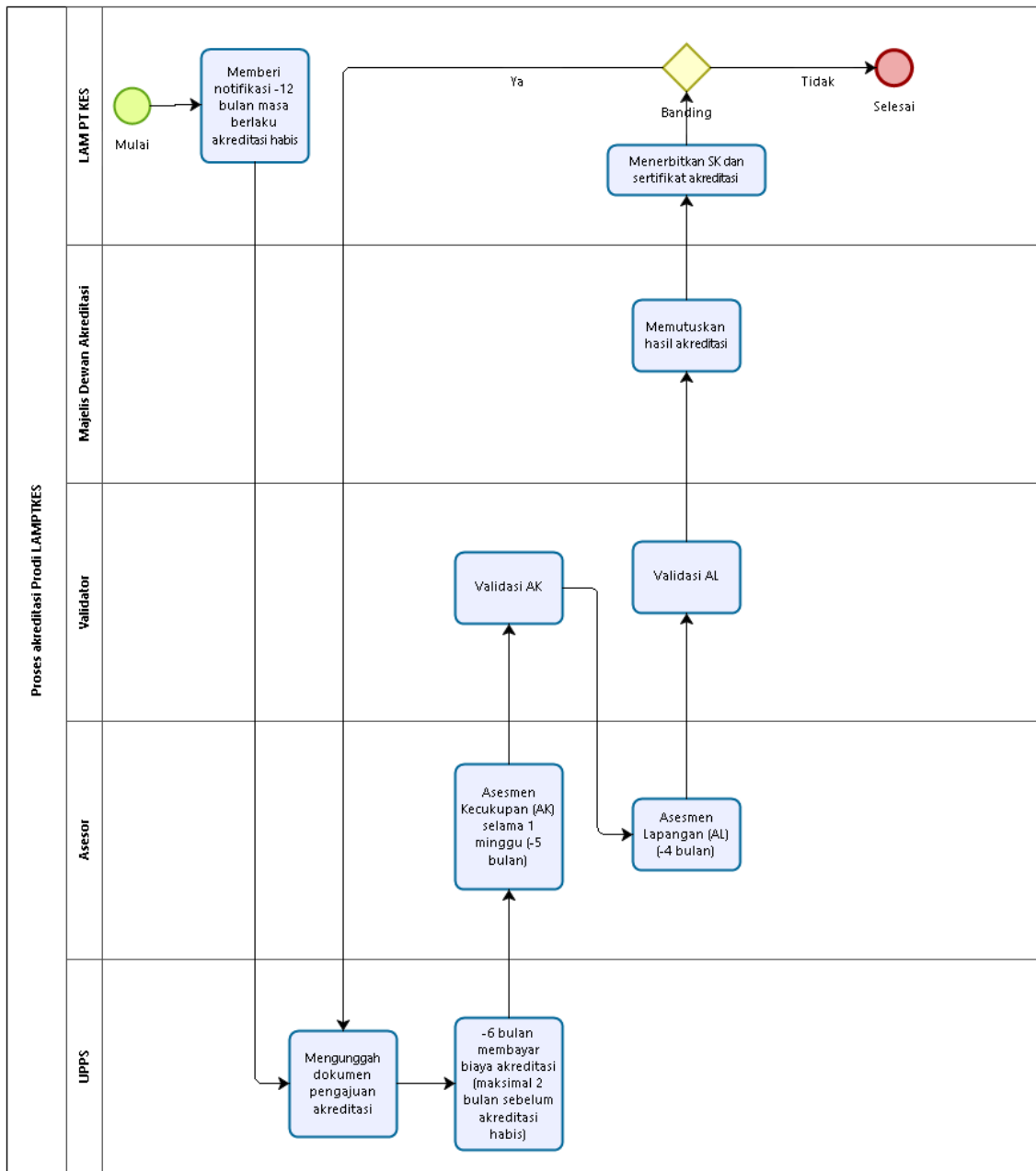

Level 2 Layanan Pemenuhan Kebutuhan Pokok dan Fasilitasi ATK

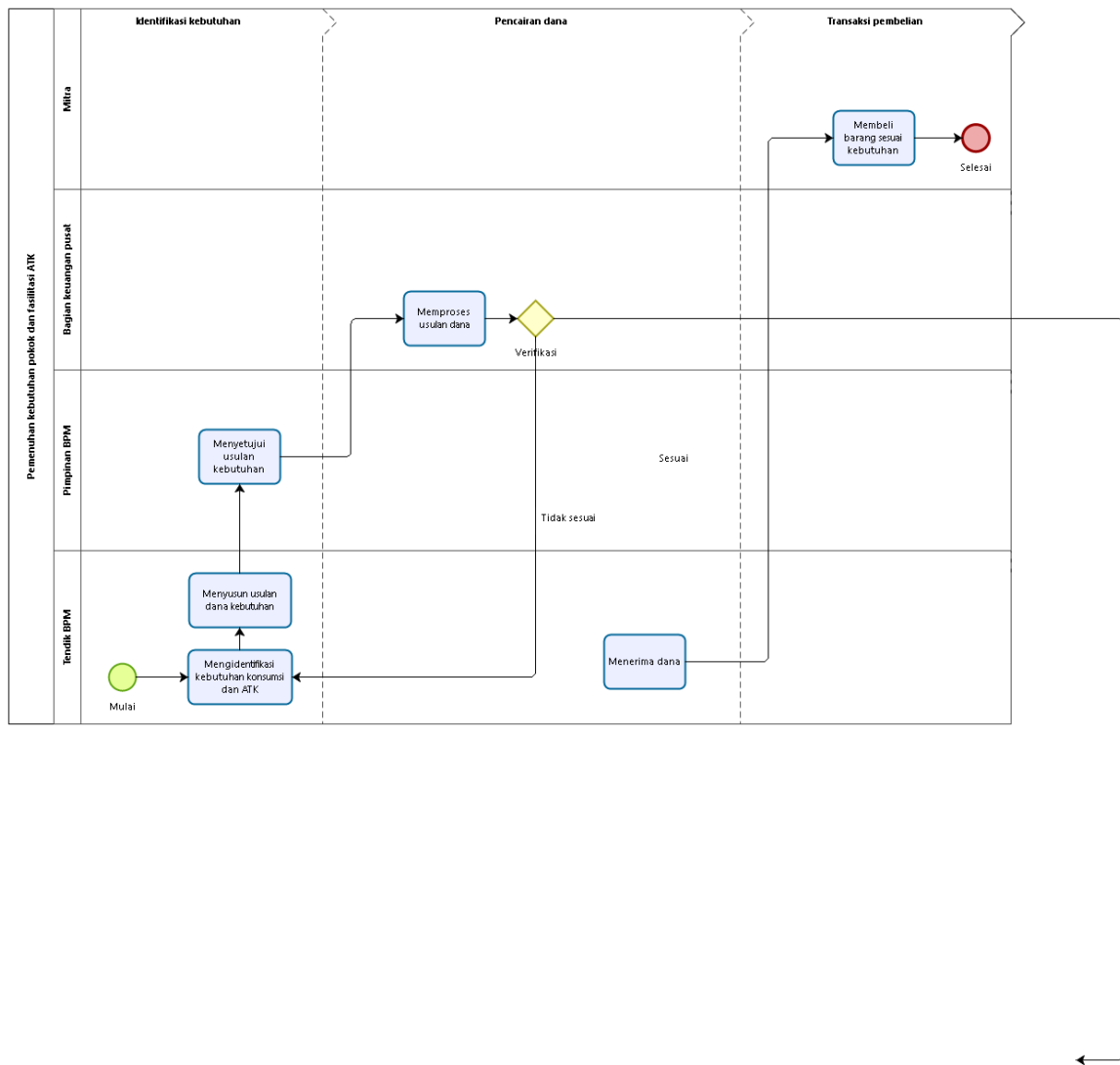

Powered by
bizagi
Modeler

Level 2 Layanan Pembayaran Gaji Tenaga Kependidikan Kontrak PPK

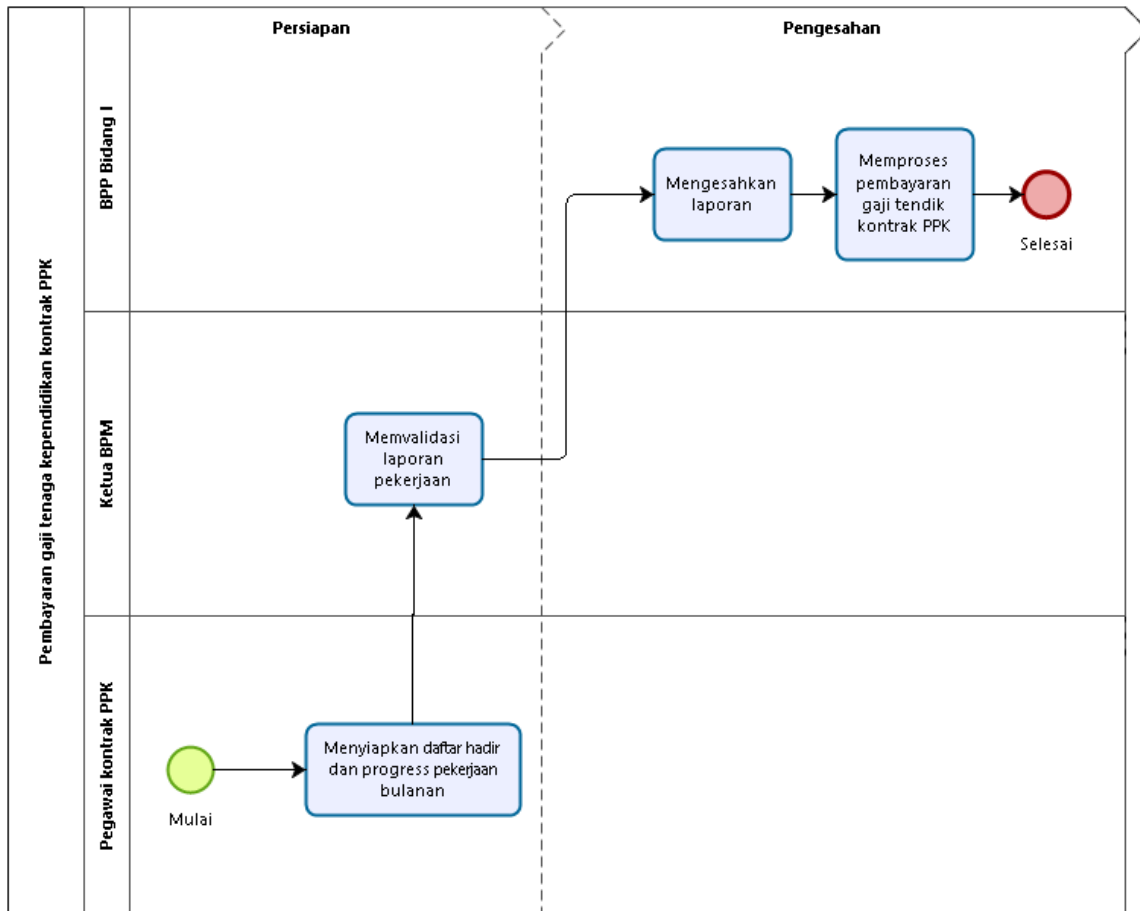

Level 2 Layanan Monev Awal Perkuliahan

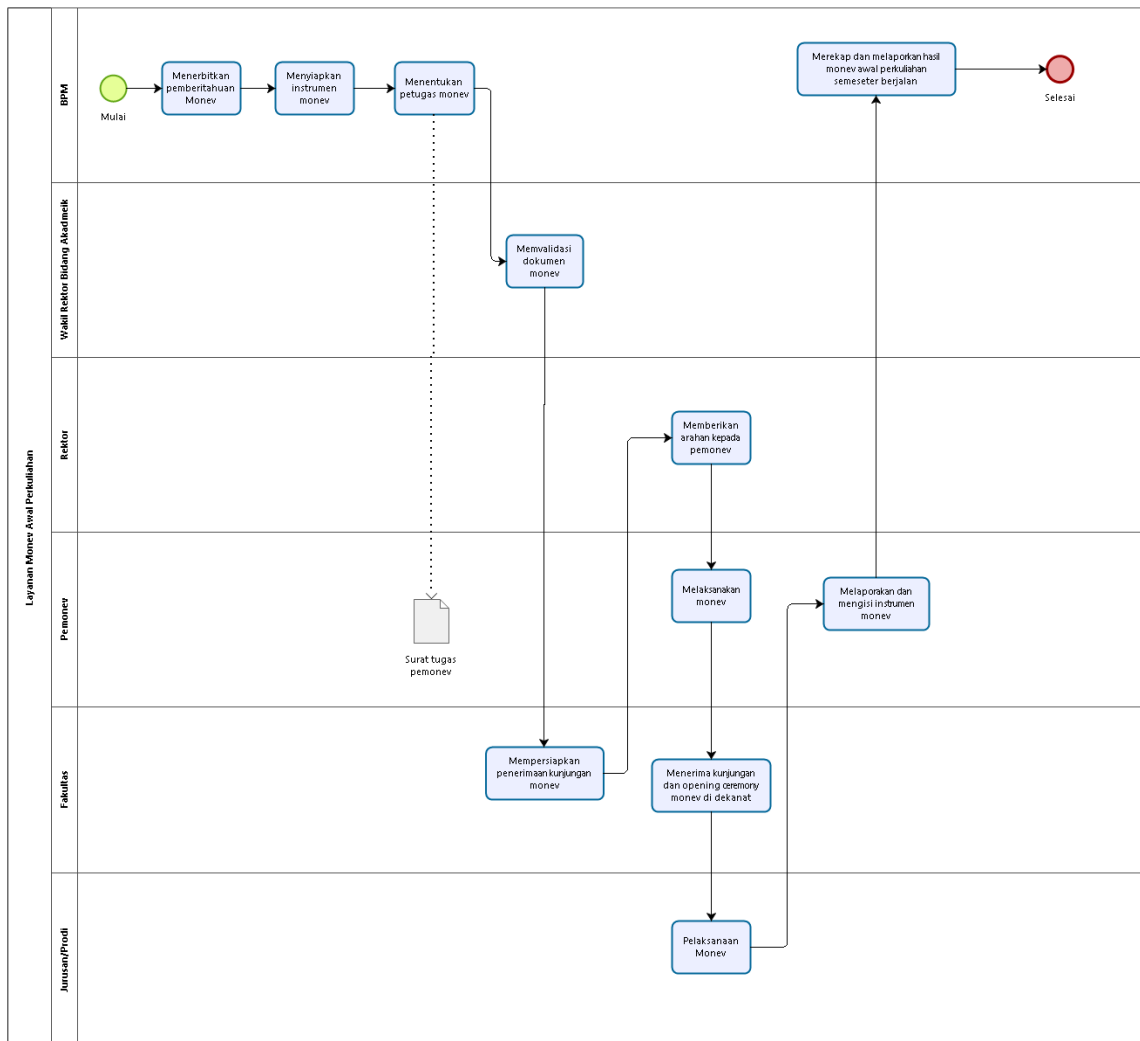

Level 2 Layanan Audit Surveillance ISO

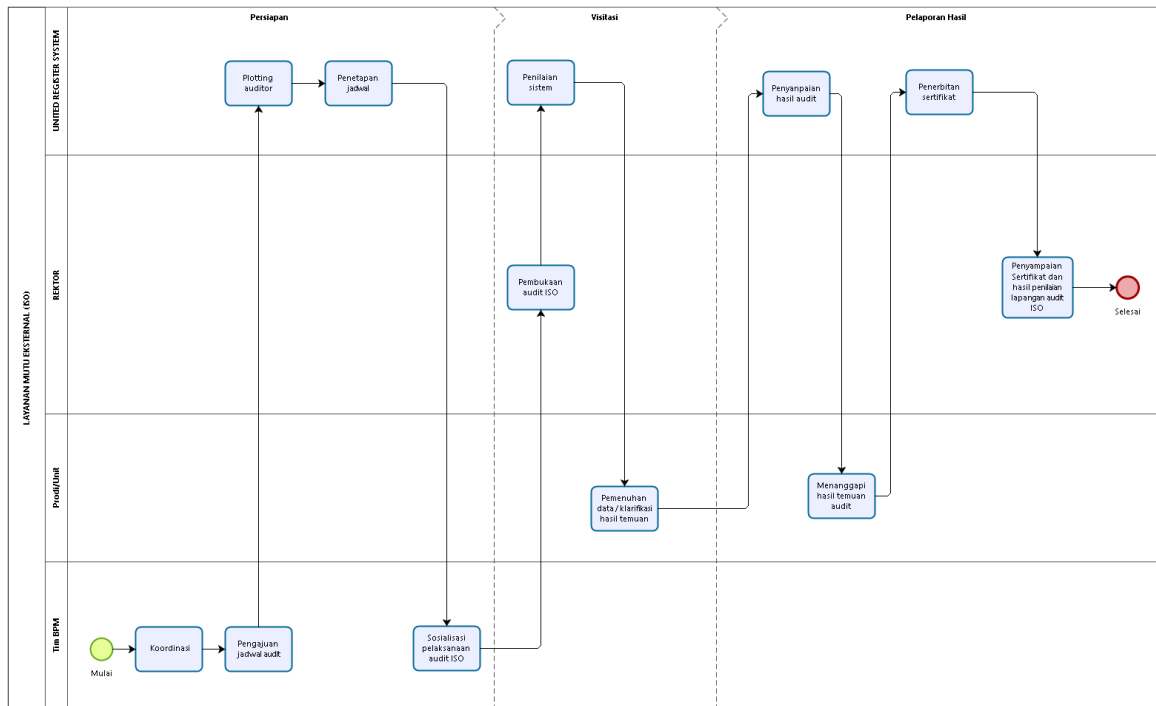

Level 2 Layanan Penerimaan Studi Banding Penjaminan Mutu

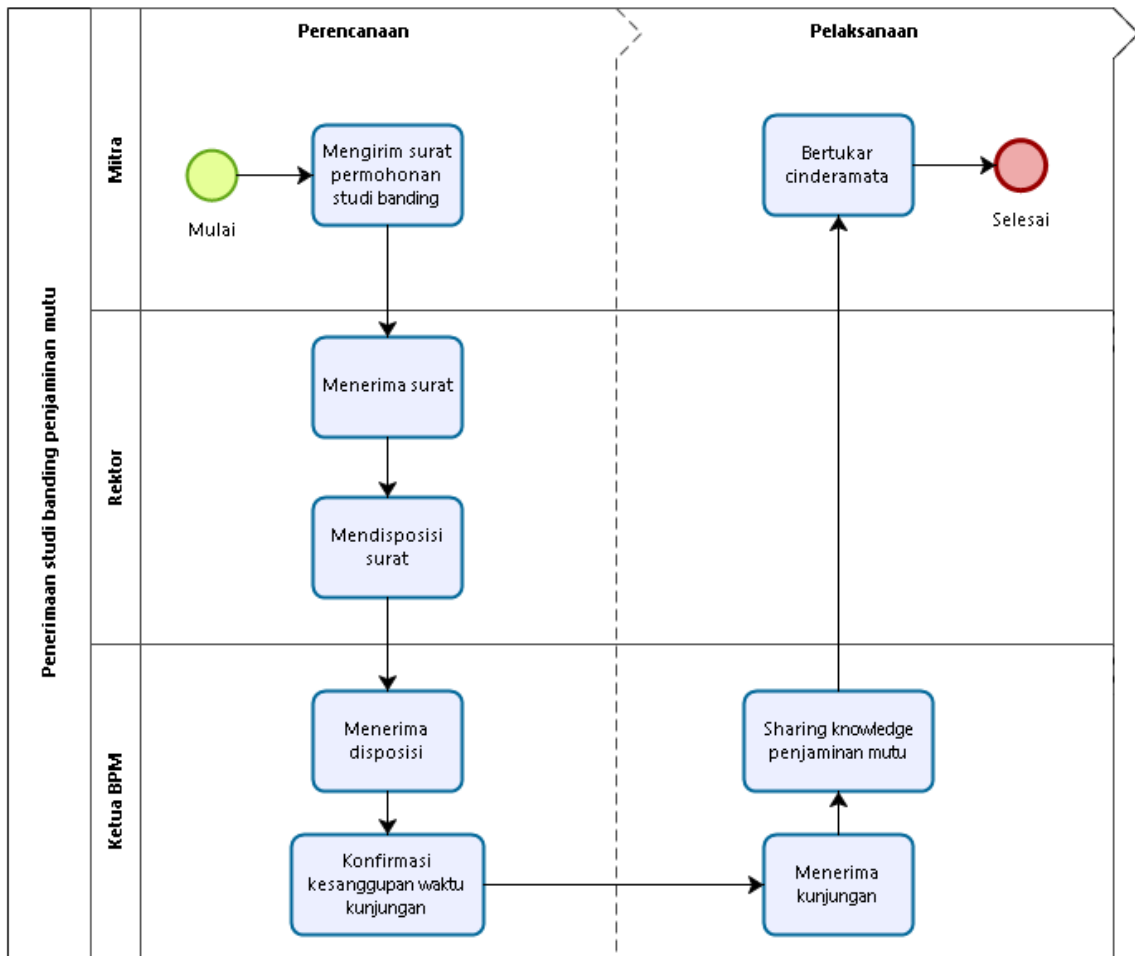

Level 2 Layanan Pengelolaan PDDIKTI

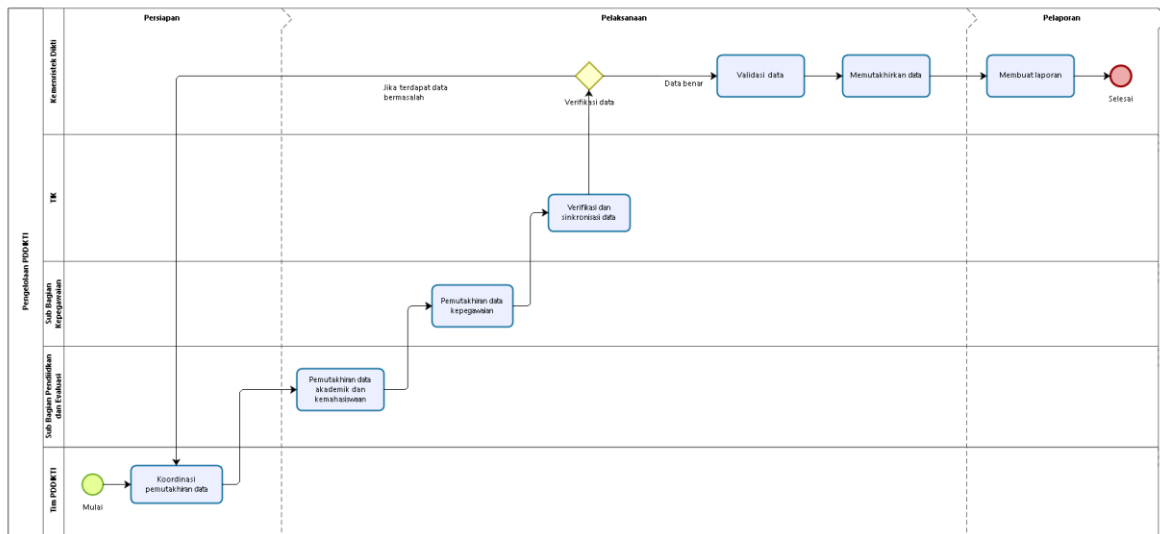

Level 1 Layanan Pengembang Bisnis

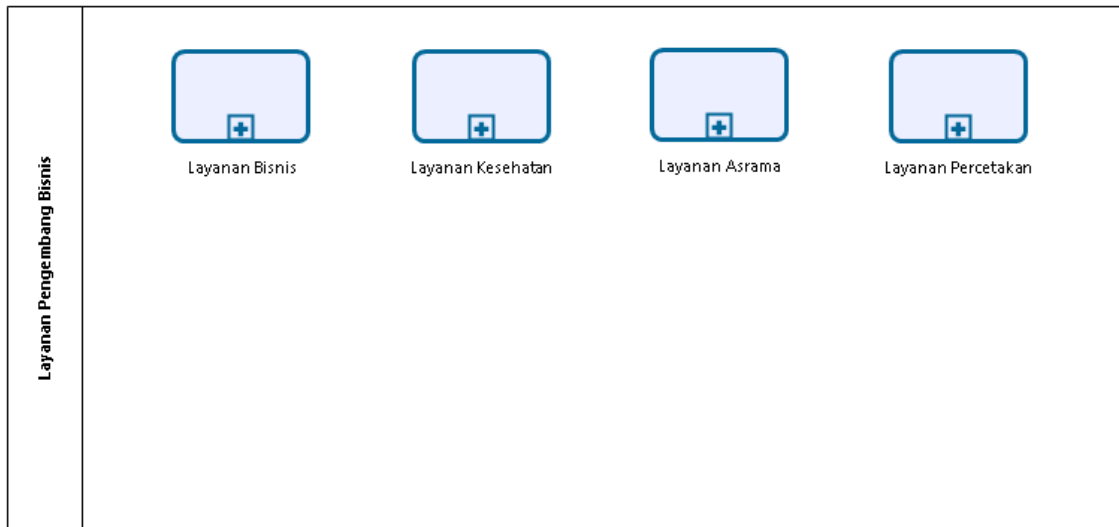

Powered by
bizagi
Modeler

Level 2 Layanan Bisnis

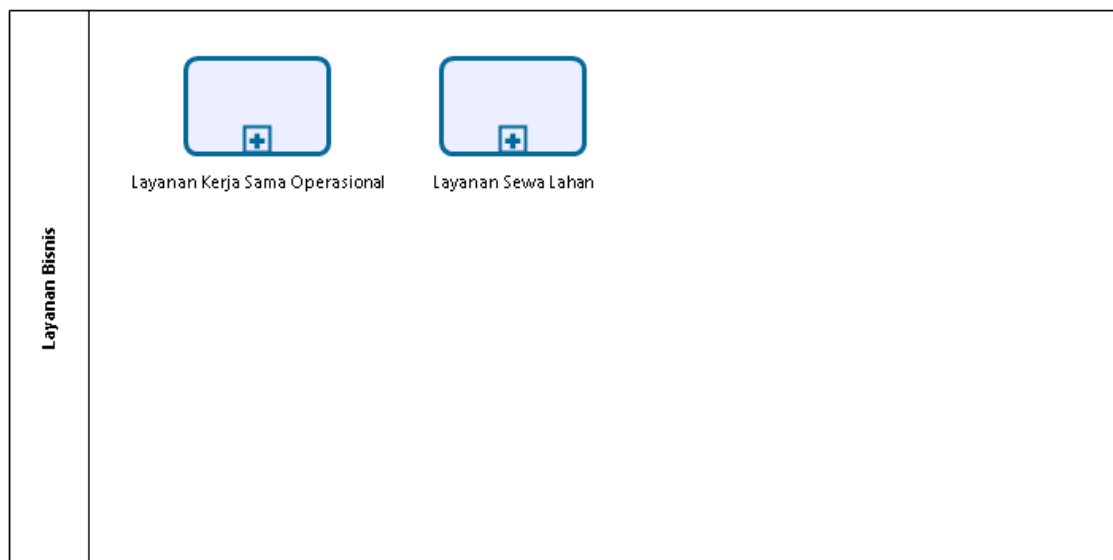

Powered by
bizagi
Modeler

Level 3 Layanan Kerja Sama Operasional

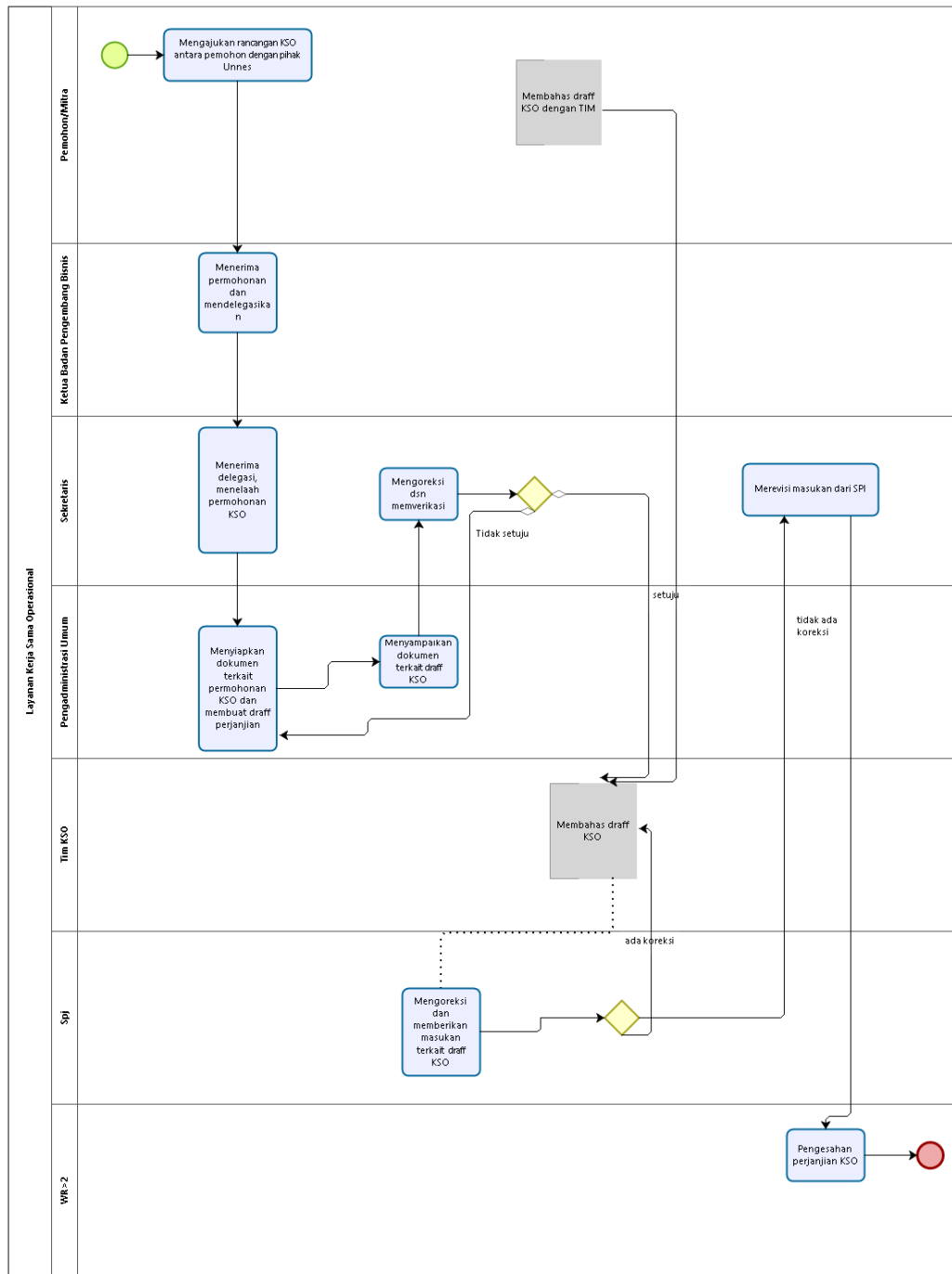

Level 3 Layanan Sewa Lahan

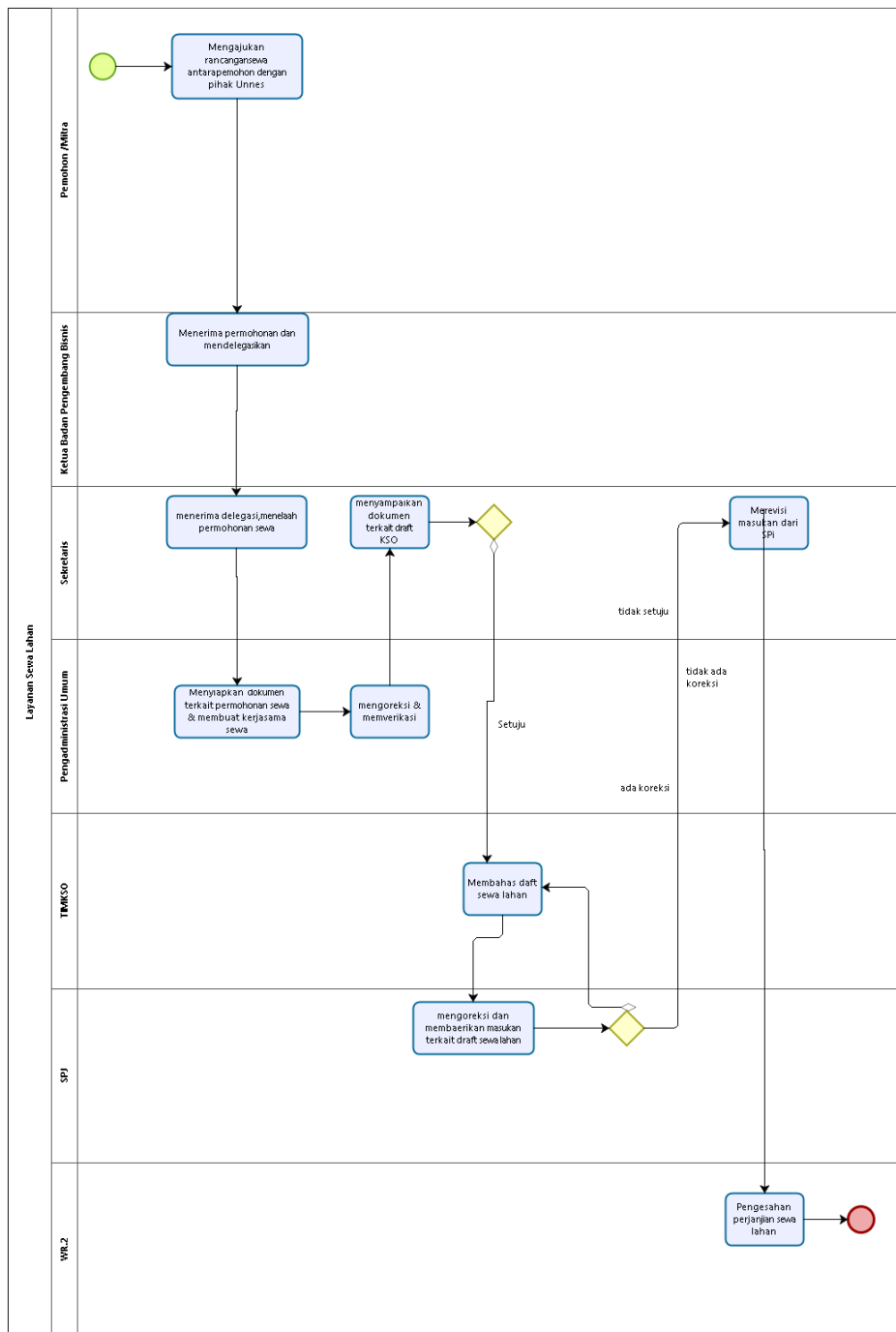

Level 2 Layanan Kesehatan

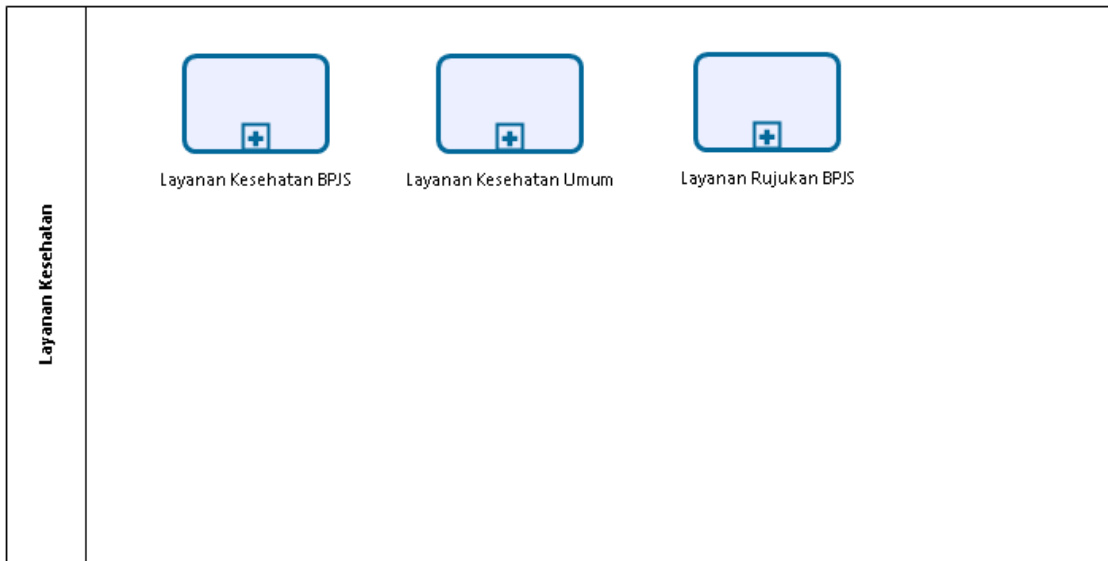

Level 3 Layanan Kesehatan BPJS

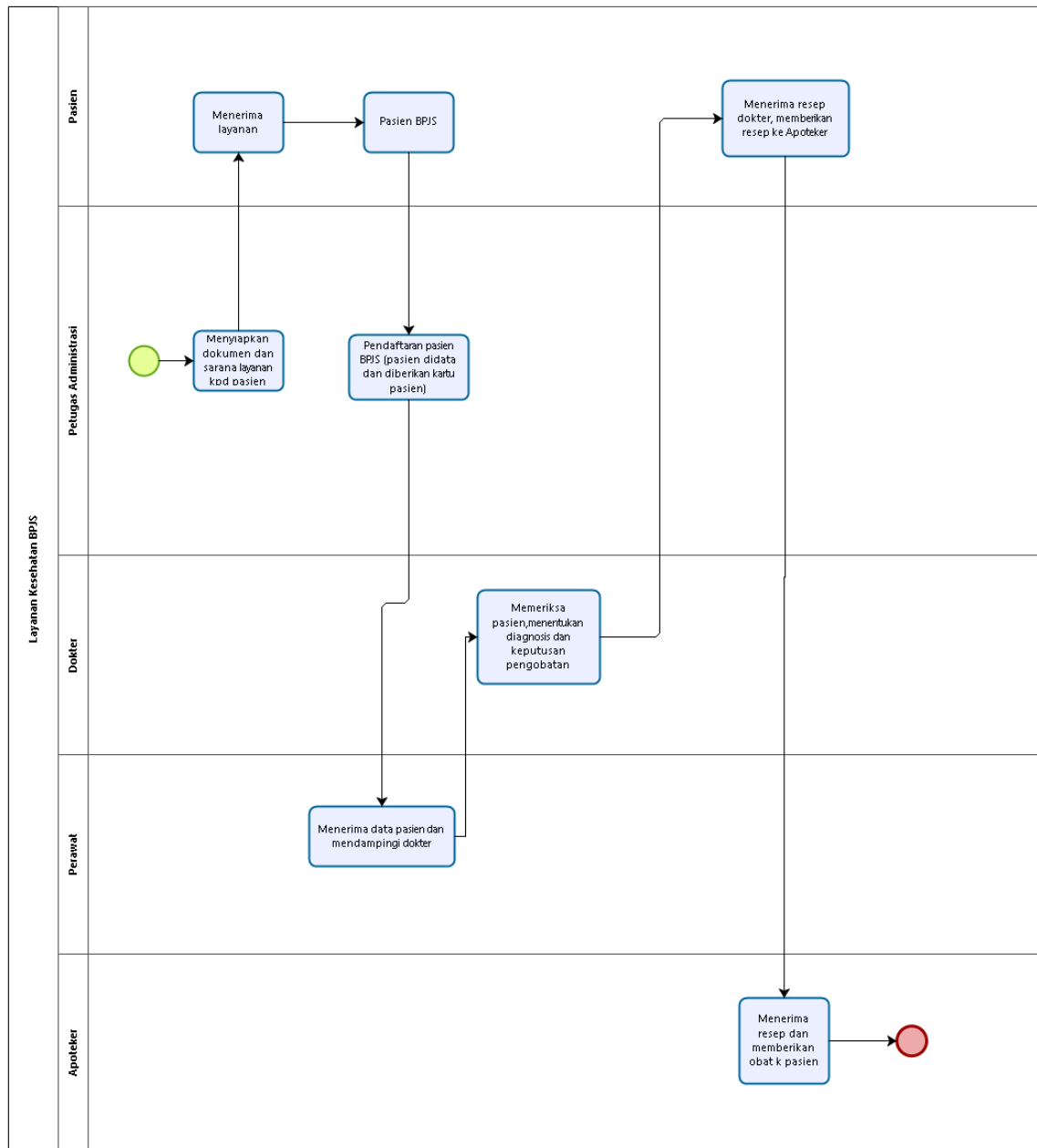

Level 3 Layanan Kesehatan Umum

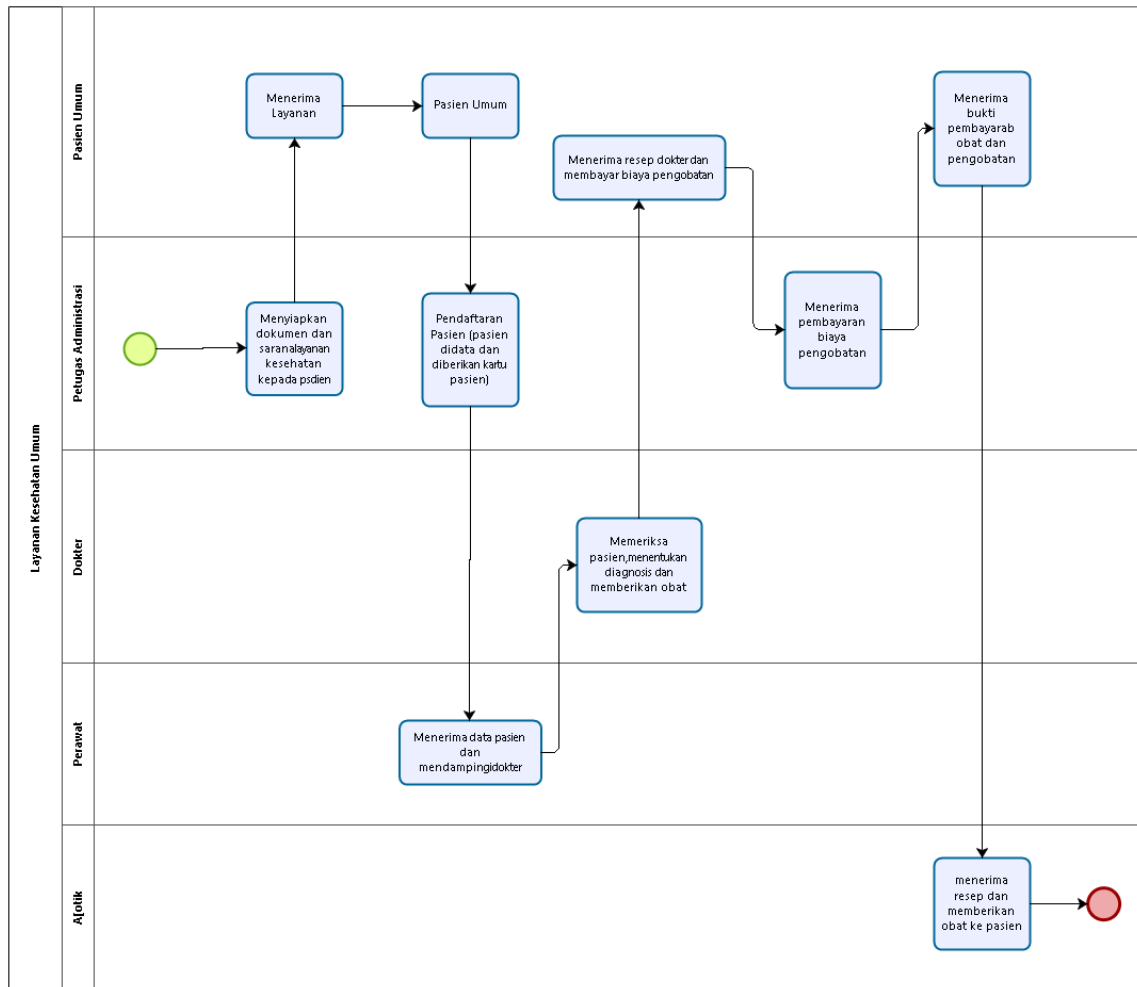

Level 3 Layanan Rujukan Umum

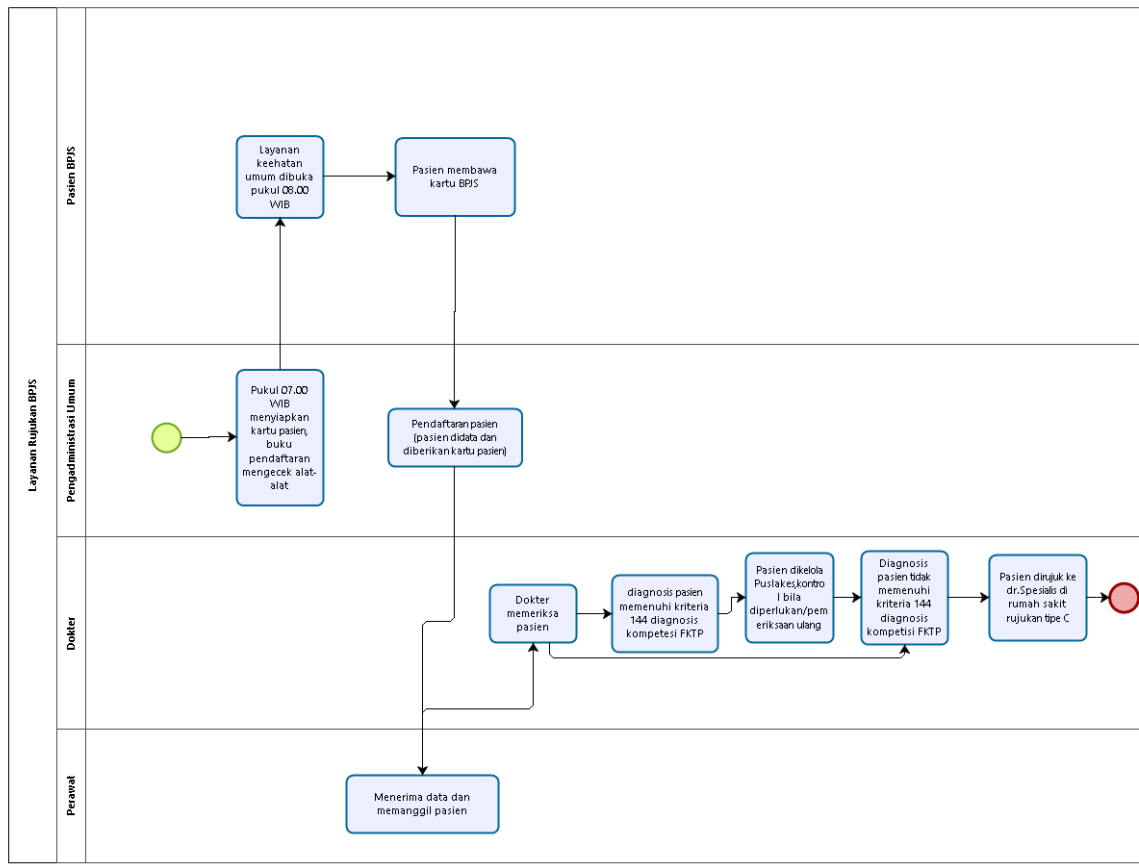

Level 2 Layanan Asrama

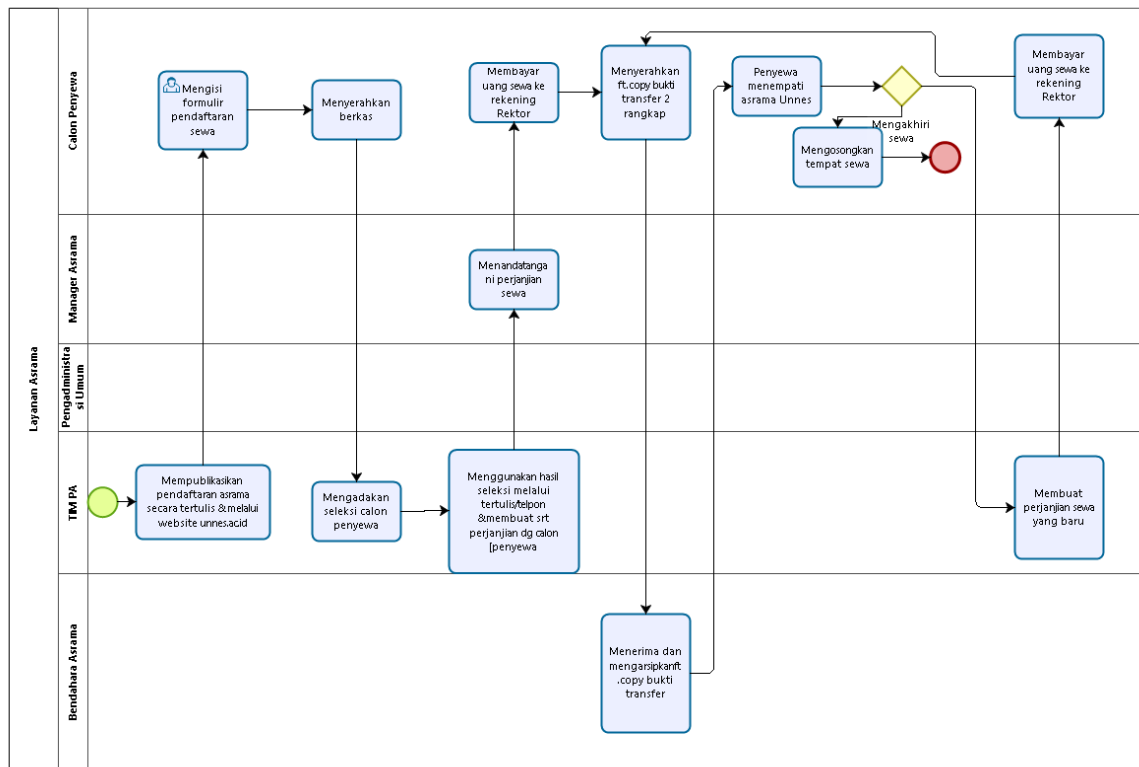

Level 2 Layanan Percetakan

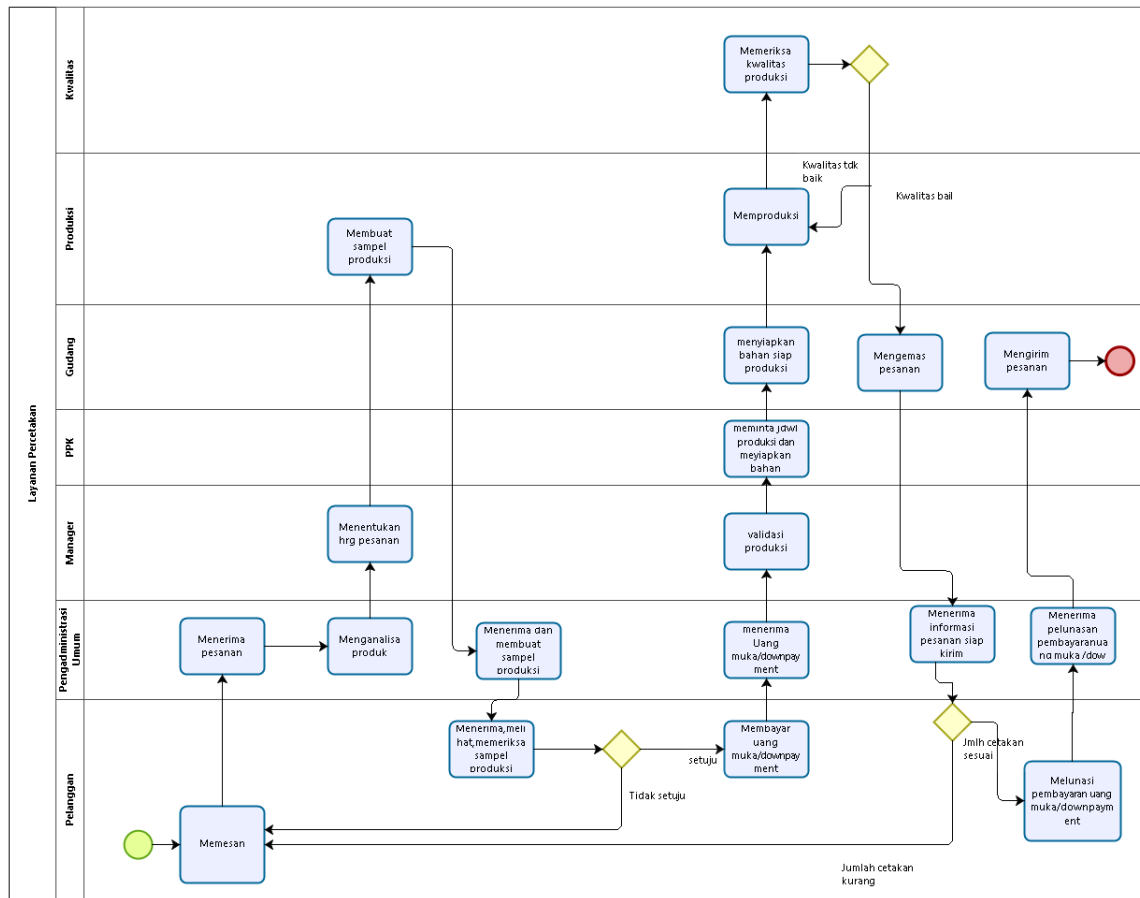

Level 1 Layanan ULT (Unit Layanan Terpadu)

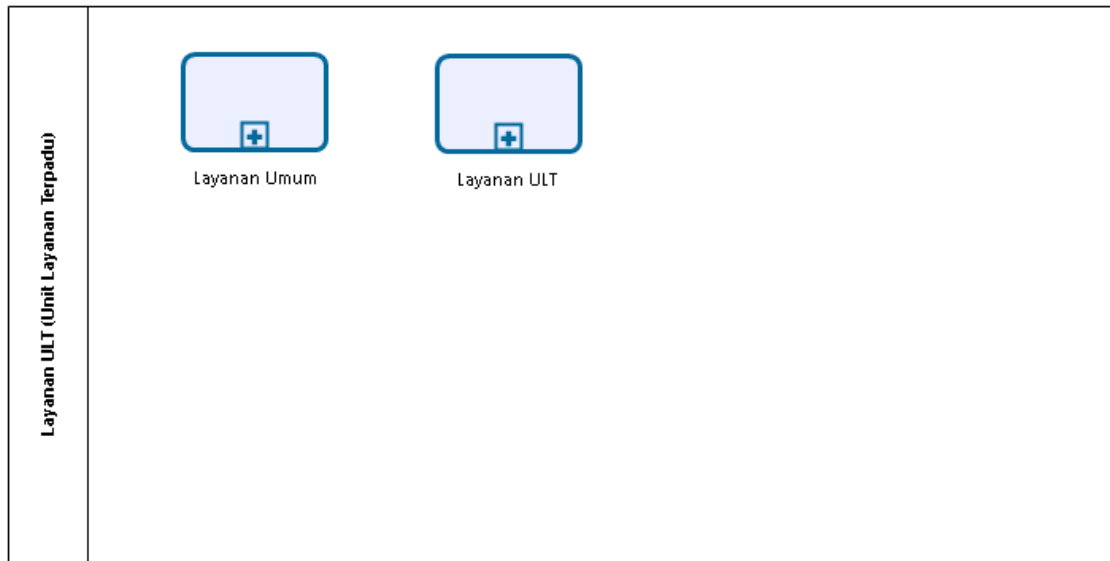

Powered by
bizagi
Modeler

Level 2 Layanan Umum ULT

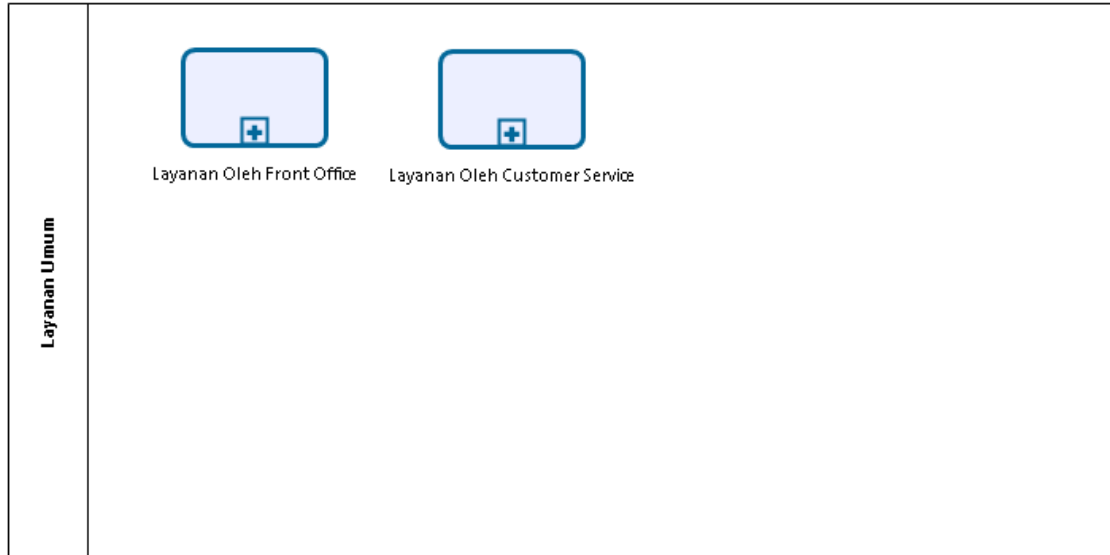

Powered by
bizagi
Modeler

Level 3 Layanan Oleh Front Office

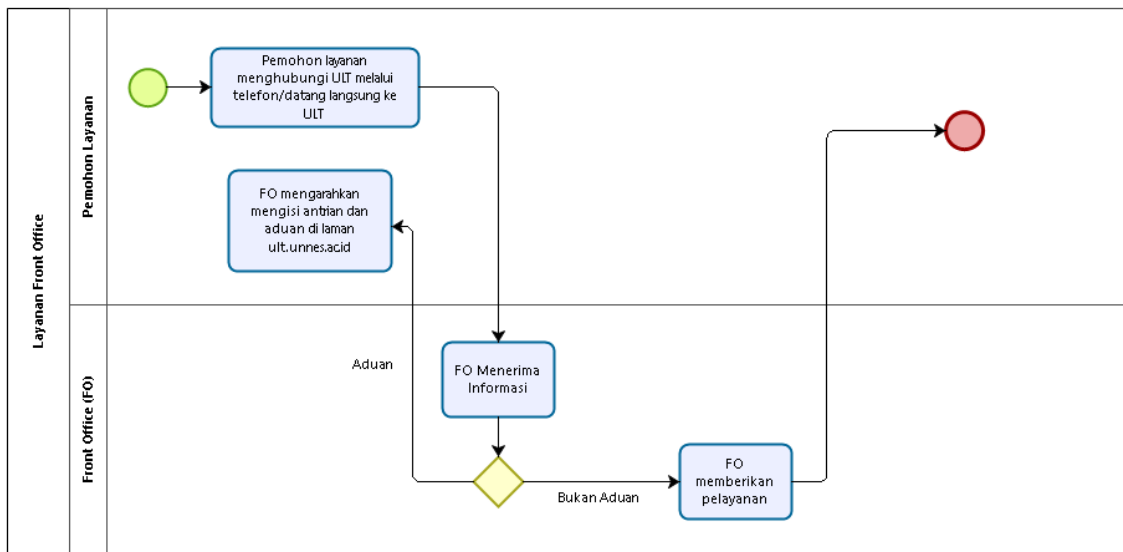

Powered by
bizagi
Modeler

Level 3 Layanan Oleh Customer Service

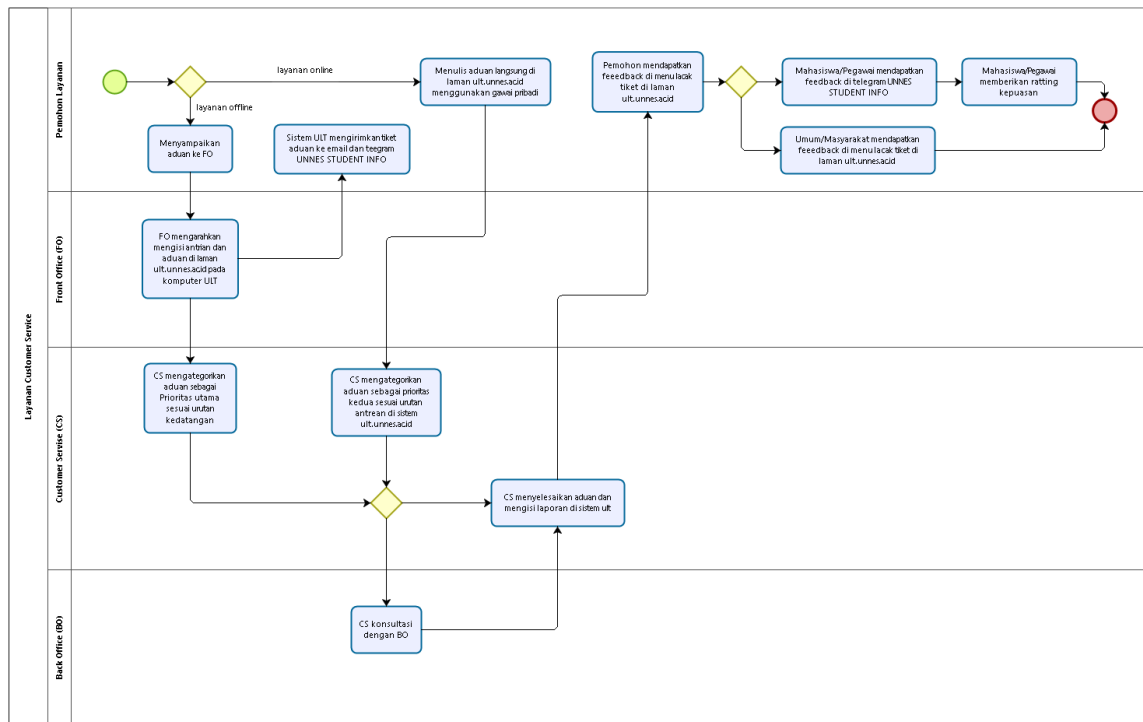

Powered by
bizagi
Modeler

Level 2 Layanan ULT

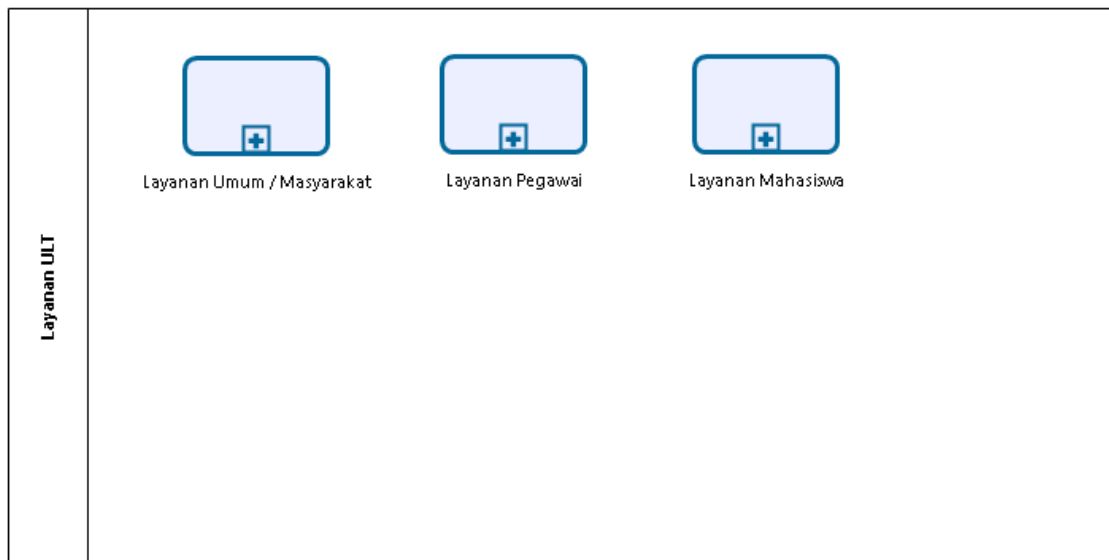

Powered by
bizagi
Modeler

Level 3 Layanan Umum / Masyarakat

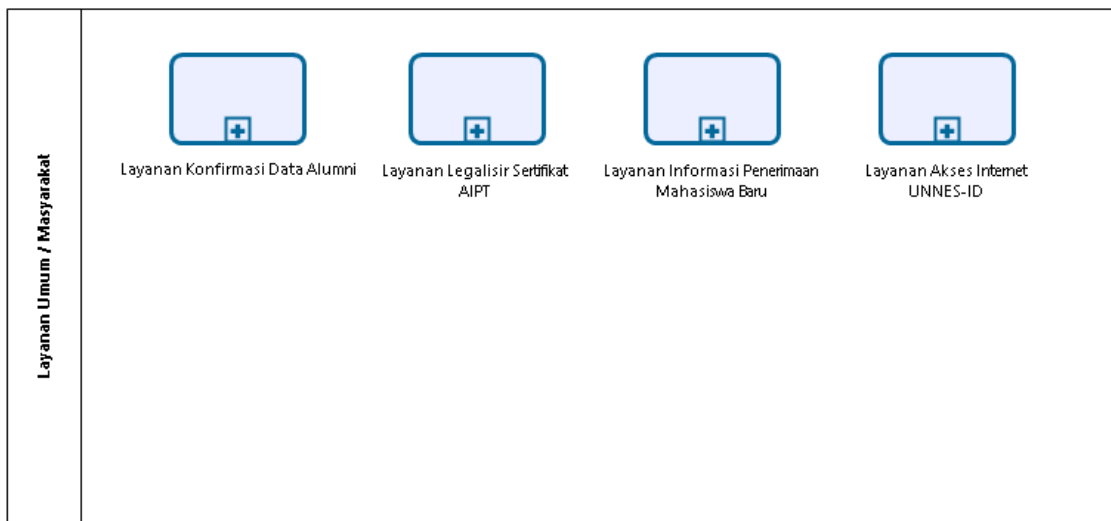

Powered by
bizagi
Modeler

Level 4 Layanan Konfirmasi Data Alumni

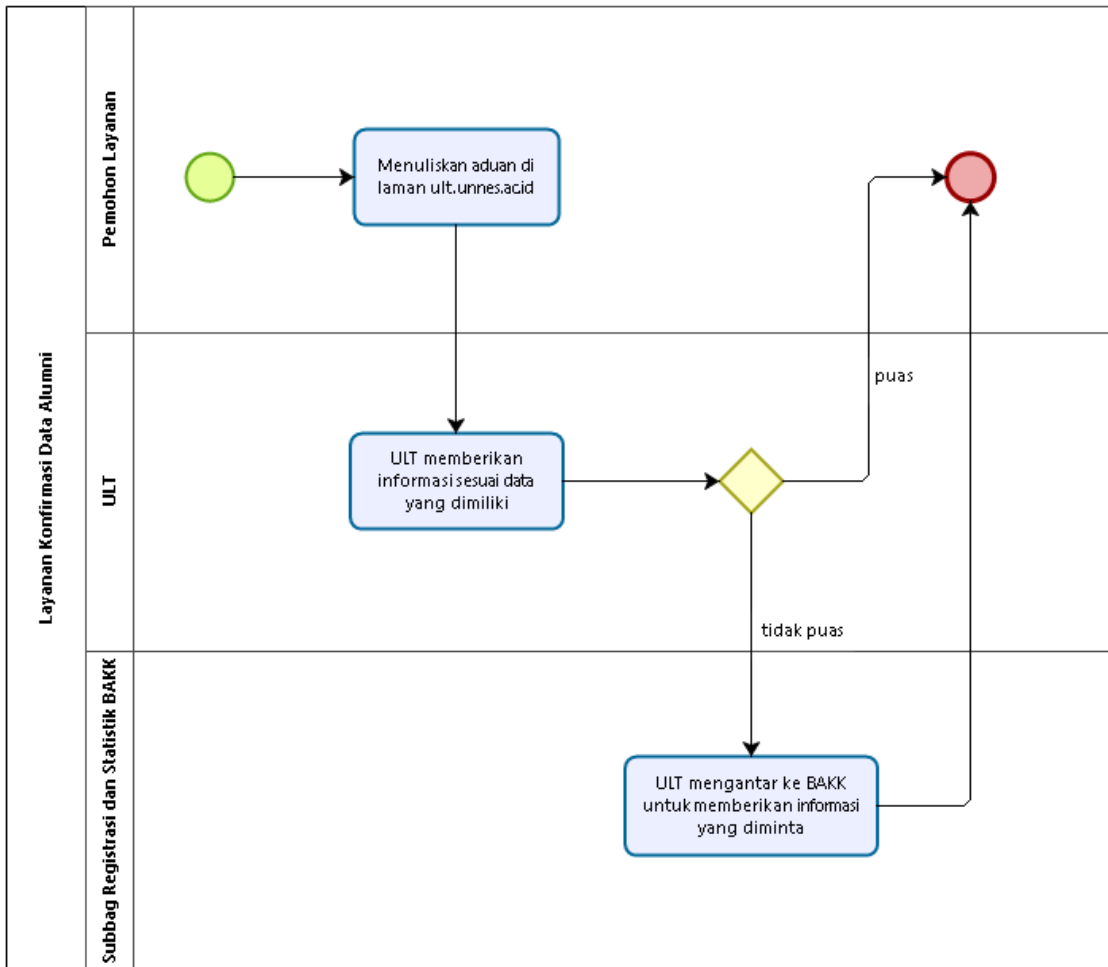

Level 4 Layanan Legalisir Sertifikat AIPT

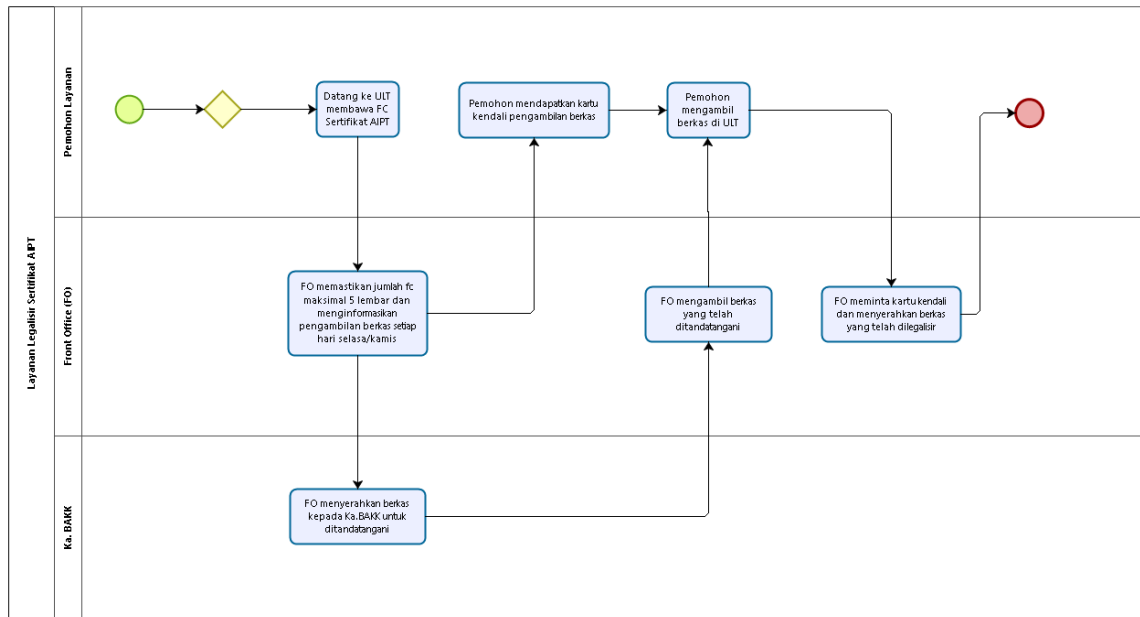

Level 4 Layanan Informasi Penerimaan Mahasiswa Baru

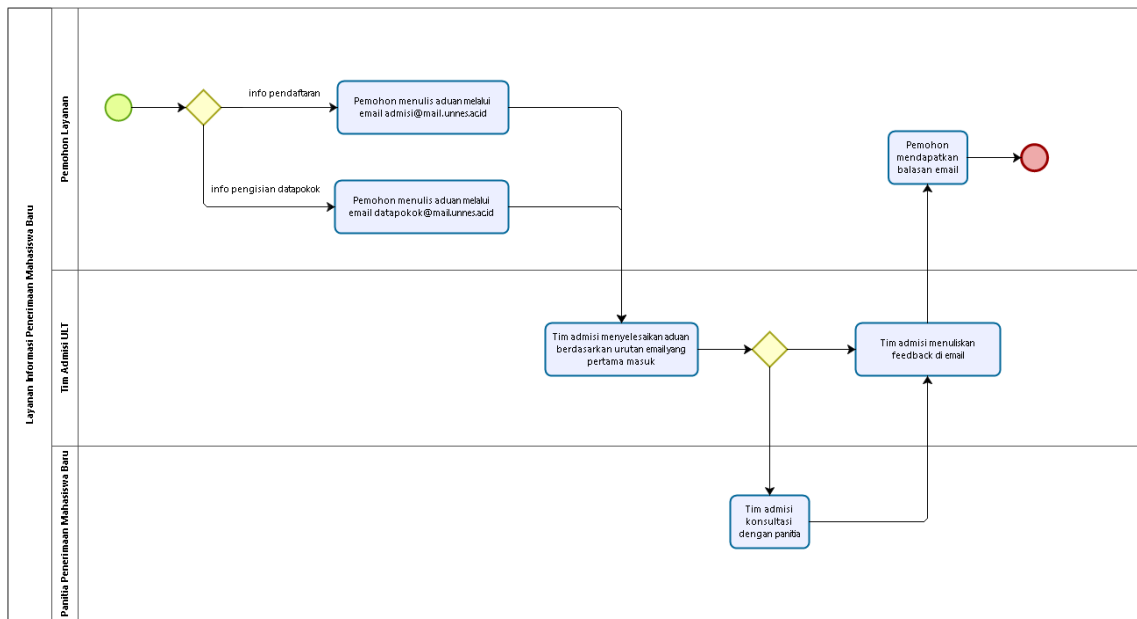

Powered by
bizagi
Modeler

Level 4 Layanan Akses Internet UNNES-ID

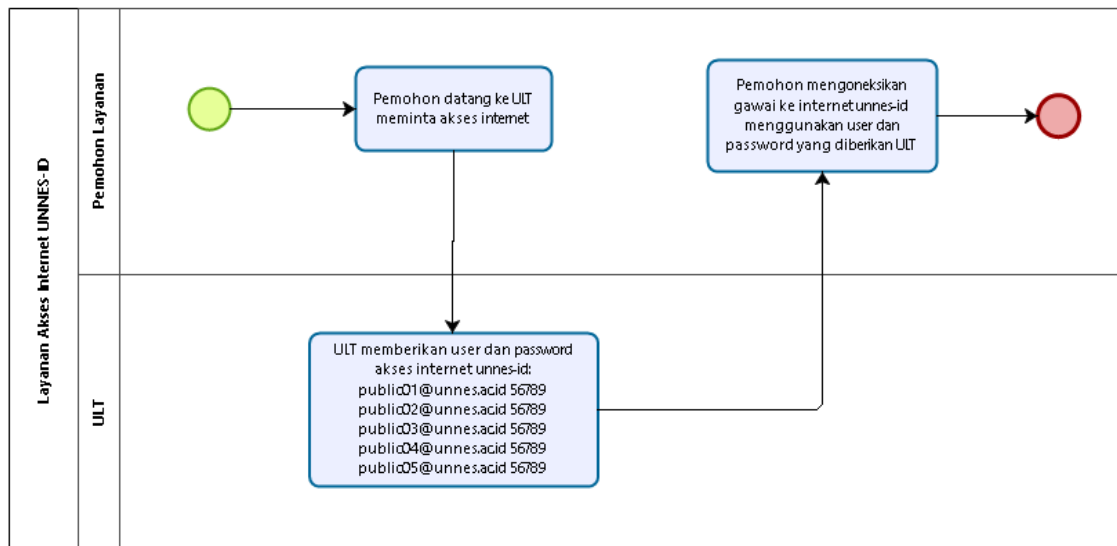

Powered by
bizagi
Modeler

Level 3 Layanan Pegawai

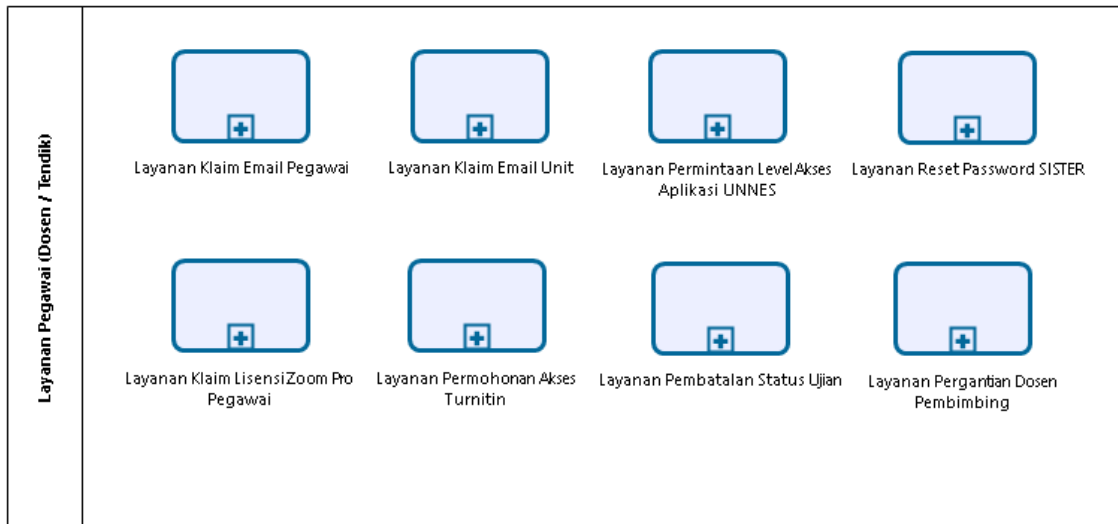

Powered by
bizagi
Modeler

Level 4 Layanan Klaim Email Pegawai

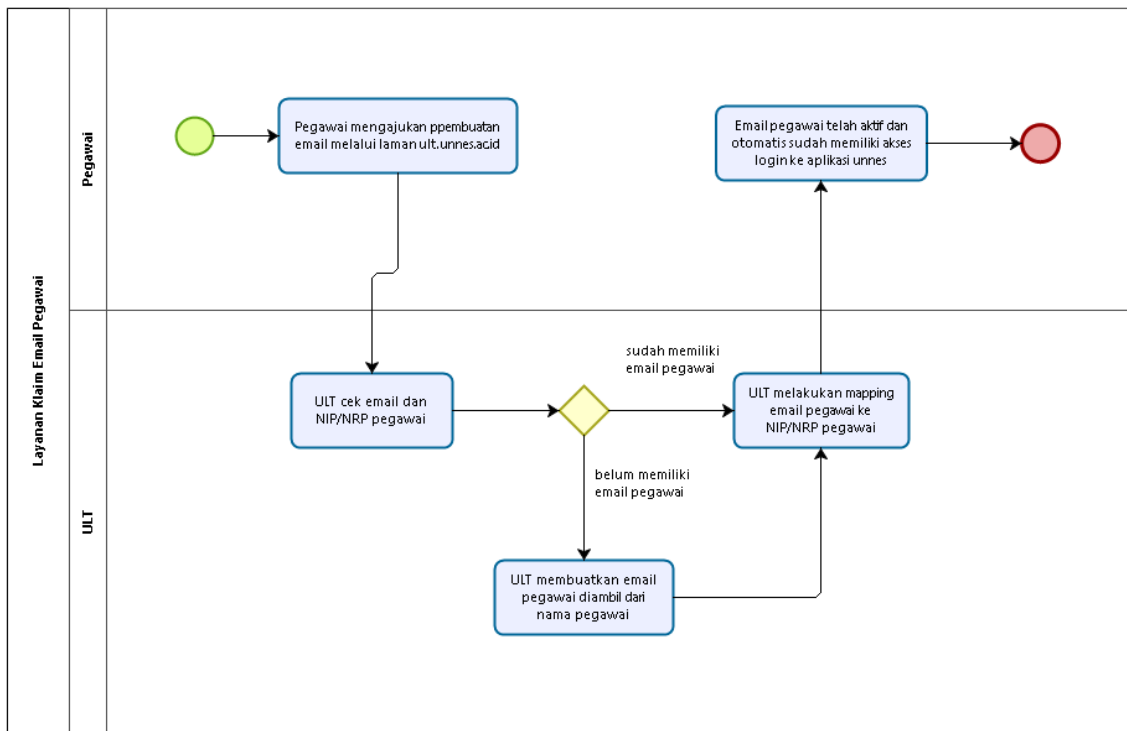

Level 4 Layanan Klaim Email Unit

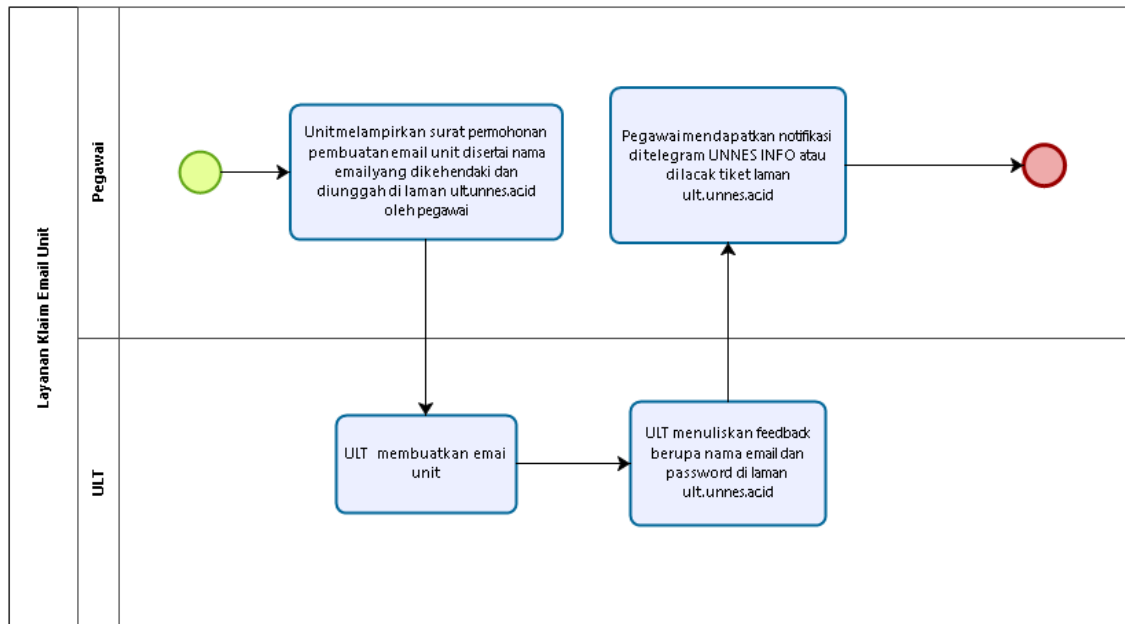

Powered by
bizagi
Modeler

Level 4 Layanan Permintaan Level Akses Aplikasi UNNES

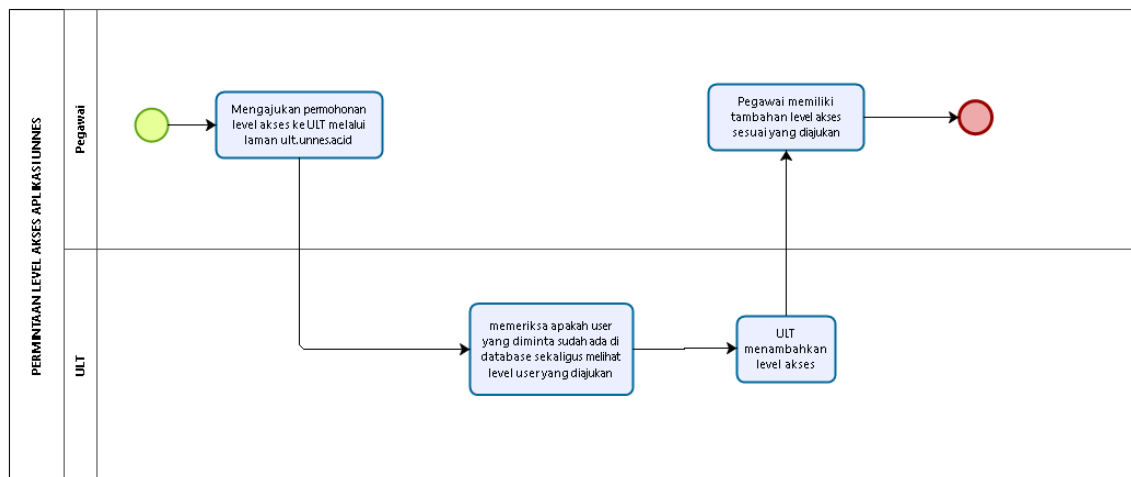

Powered by
bizagi
Modeler

Level 4 Layanan Reset Password SISTER

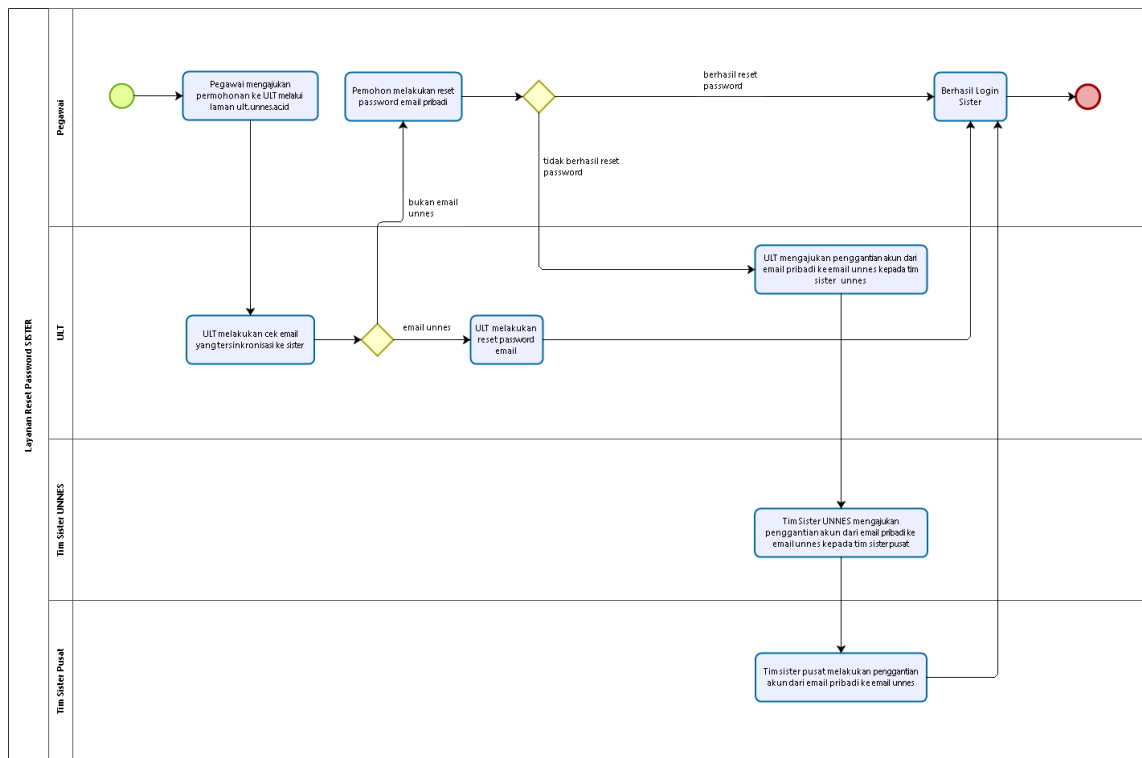

Powered by
bizagi
Modeler

Level 4 Layanan Klaim Lisensi Zoom Pro Pegawai

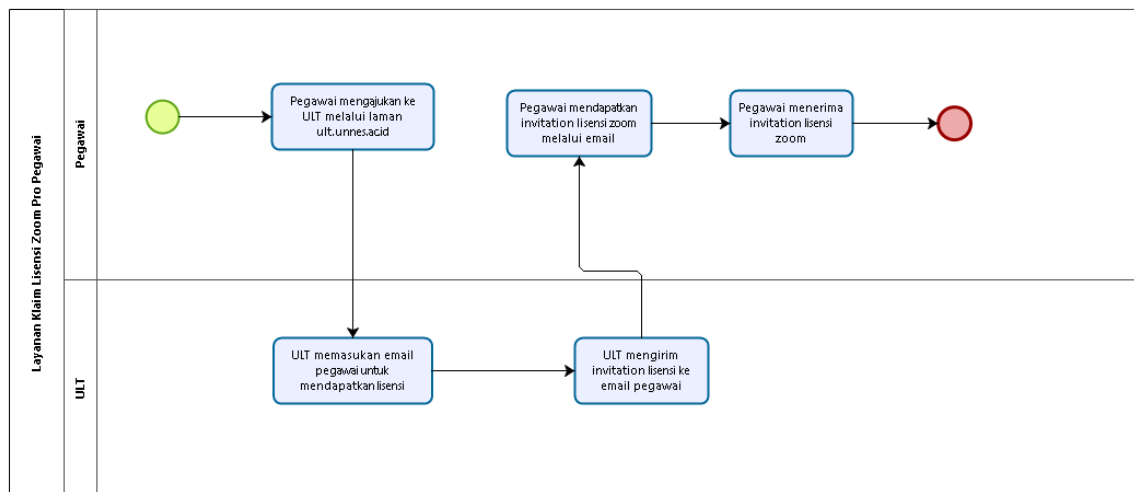

Powered by
bizagi
Modeler

Level 4 Layanan Permohonan Akses Turnitin

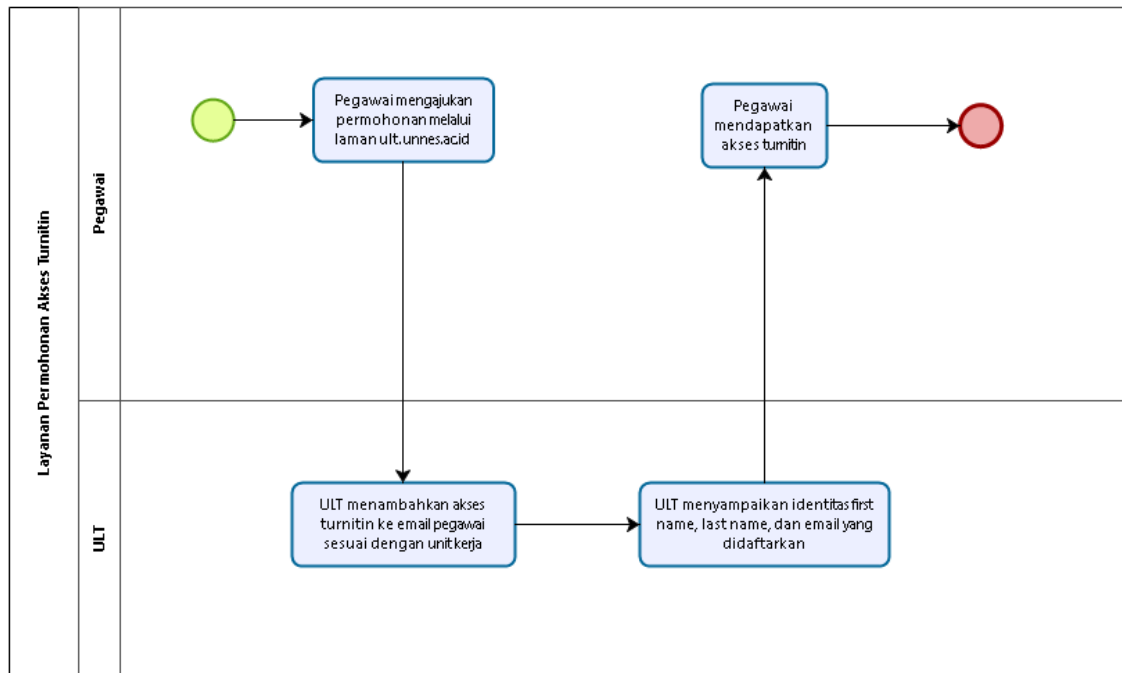

Level 4 Layanan Pembatalan Status Ujian

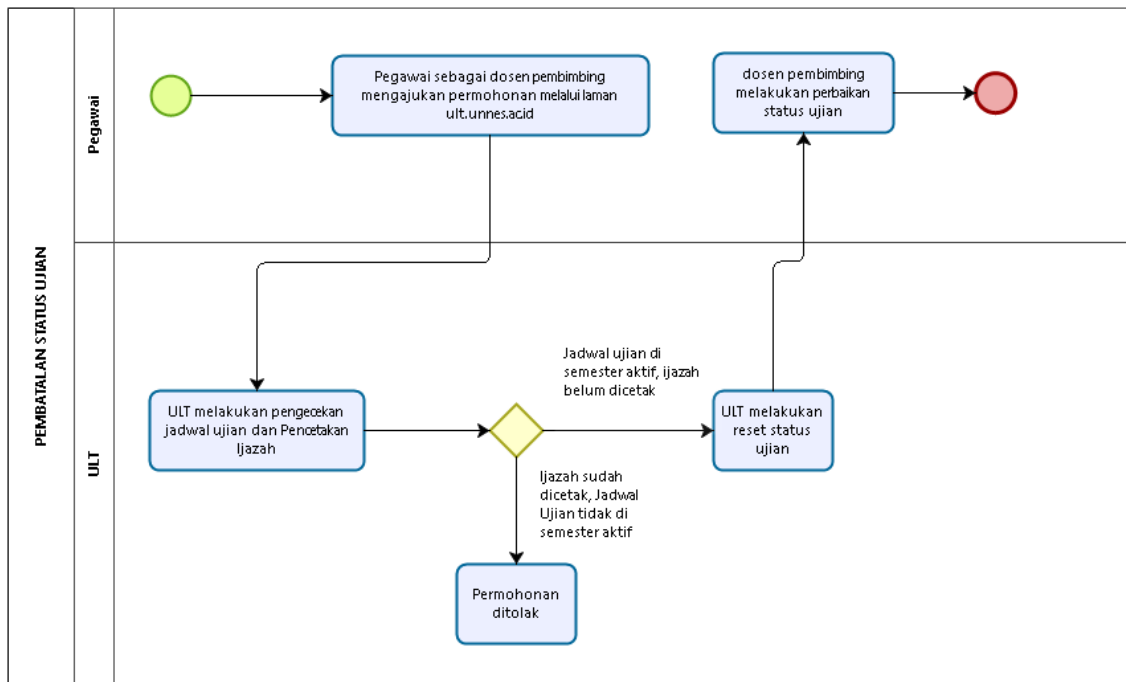

Level 4 Layanan Pergantian Dosen Pembimbing

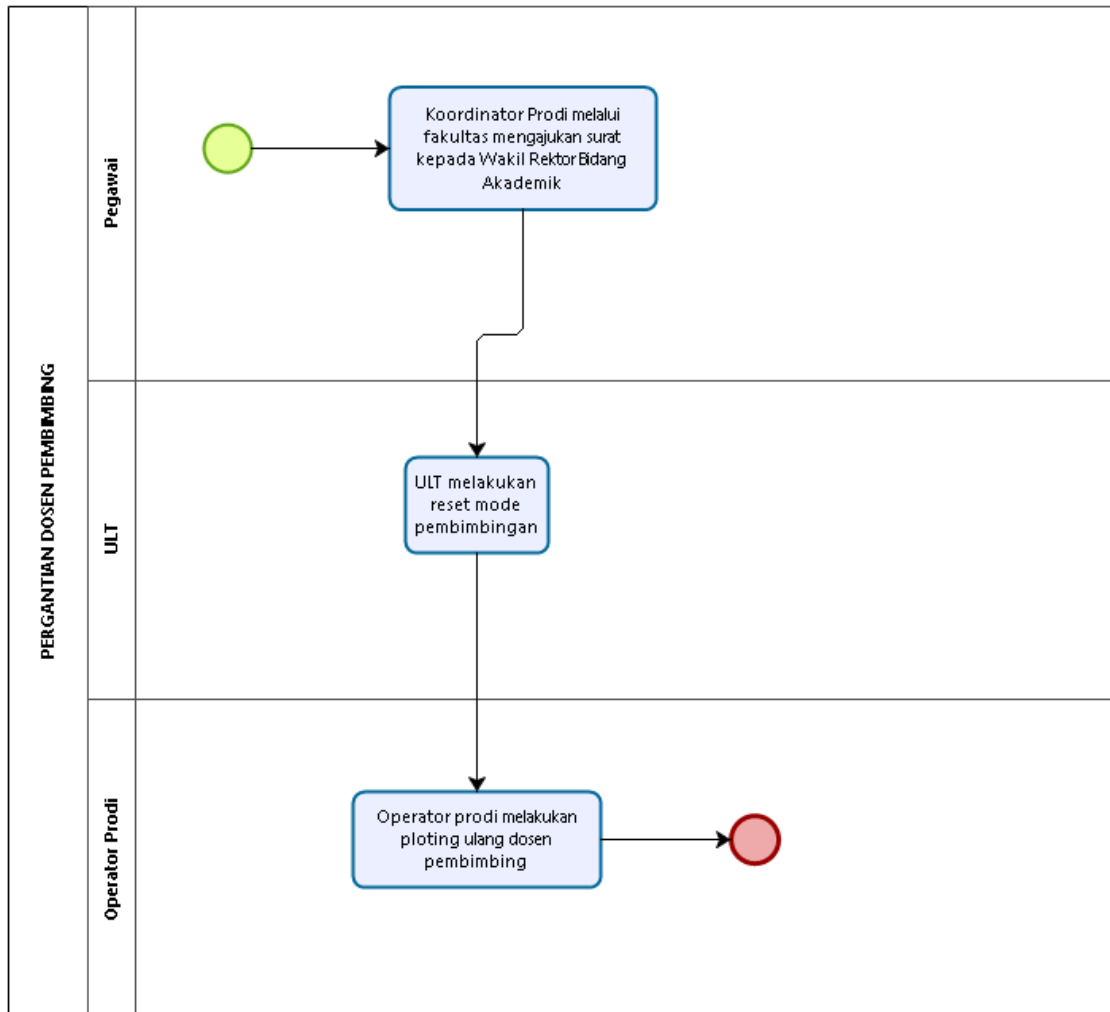

Level 3 Layanan Mahasiswa

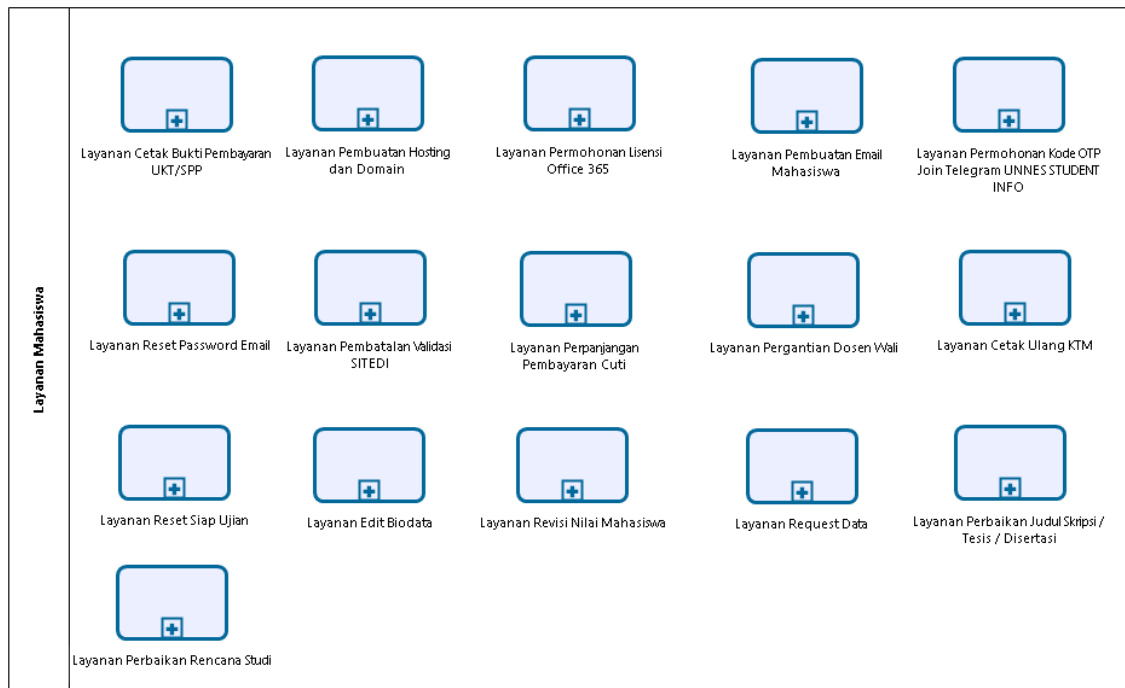

Level 4 Layanan Cetak Bukti Pembayaran UKT / SPP

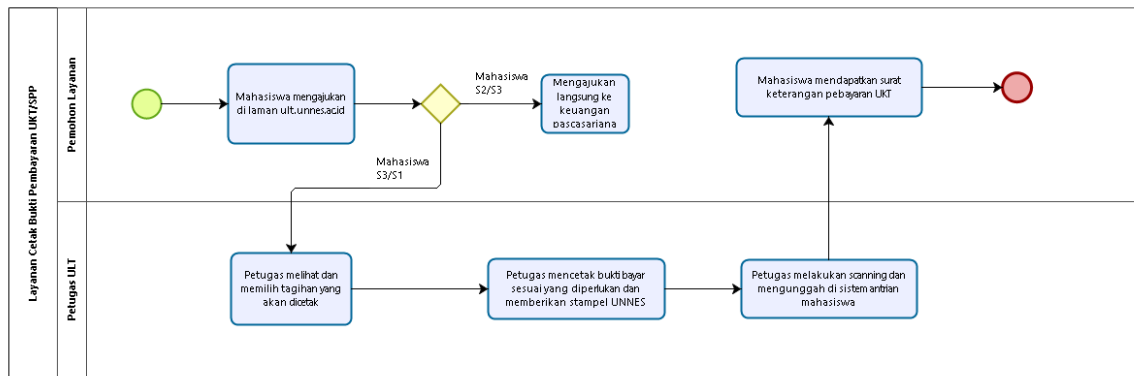

Powered by
bizagi
Modeler

Level 4 Layanan Pembuatan Hosting dan Domain

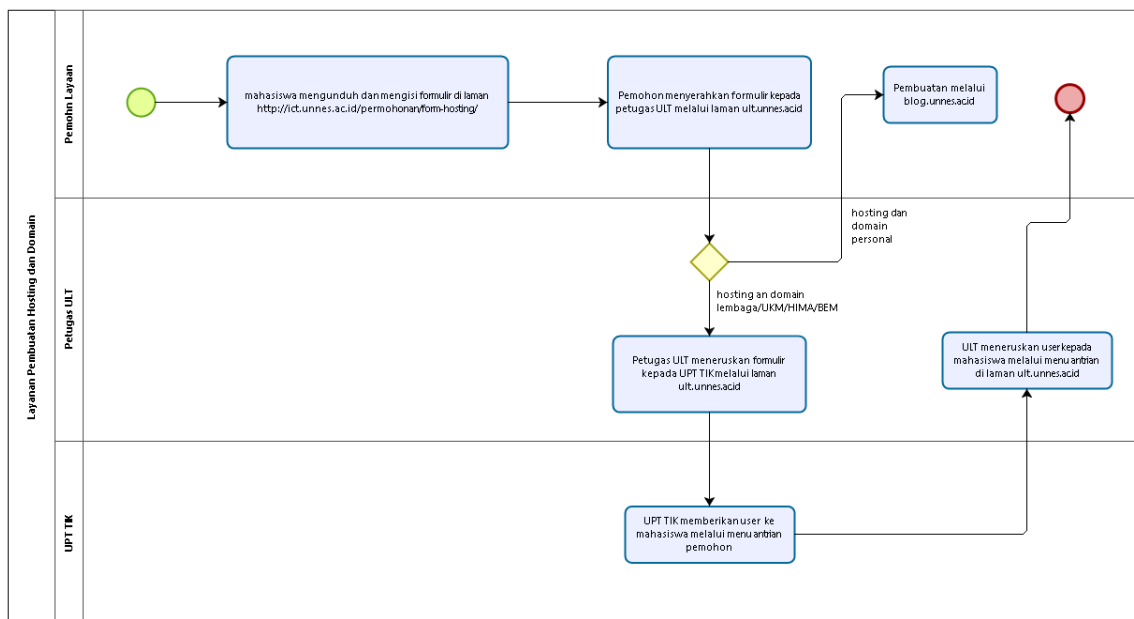

Powered by
bizagi
Modeler

Level 4 Layanan Permohonan Lisensi Office 365

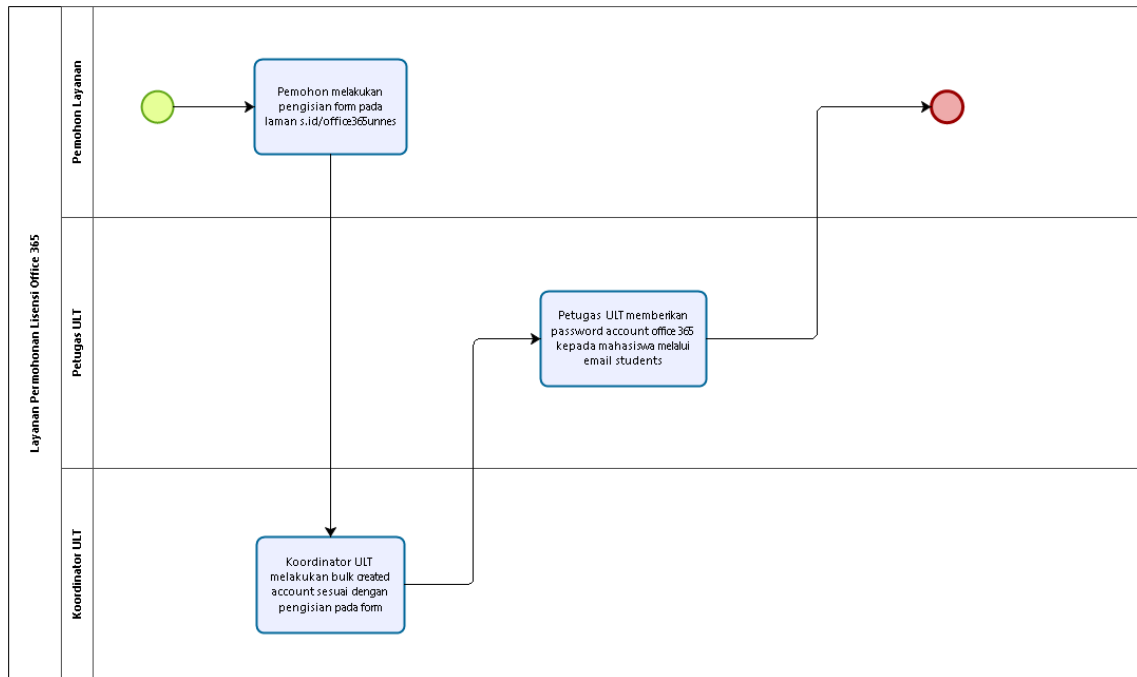

Powered by
bizagi
Modeler

Level 4 Layanan Pembuatan Email Mahasiswa

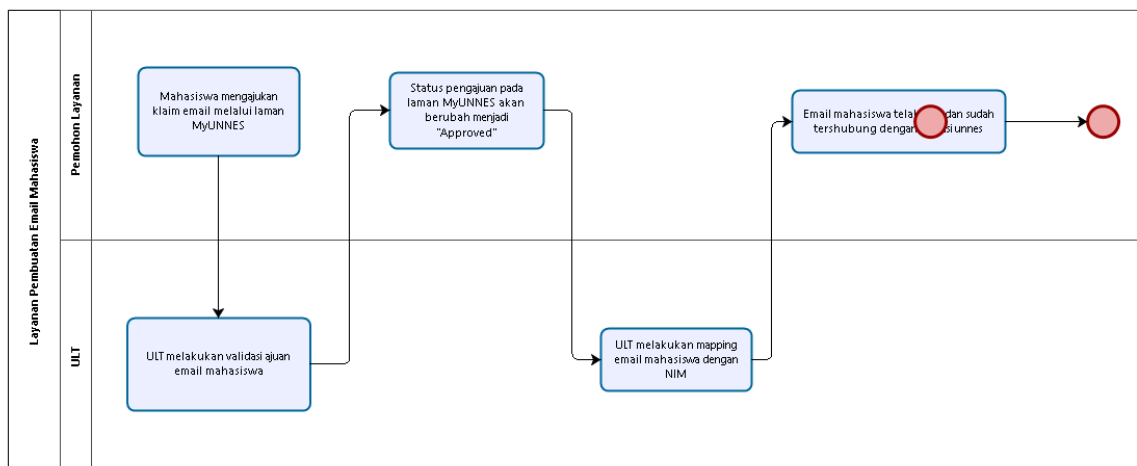

Powered by
bizagi
Modeler

Level 4 Layanan Permohonan Kode OTP Join Telegram UNNES STUDENT INFO

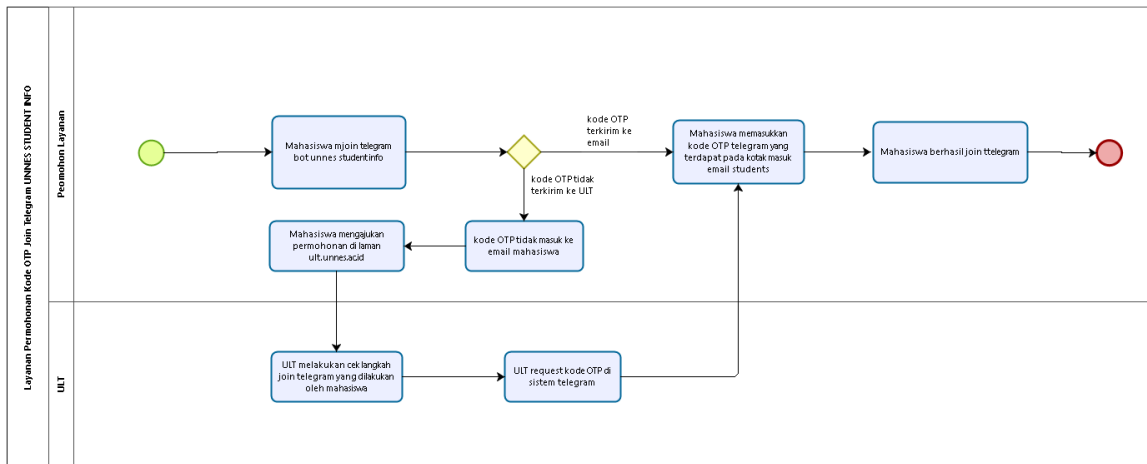

Powered by
bizagi
Modeler

Level 4 Layanan Reset Password Email

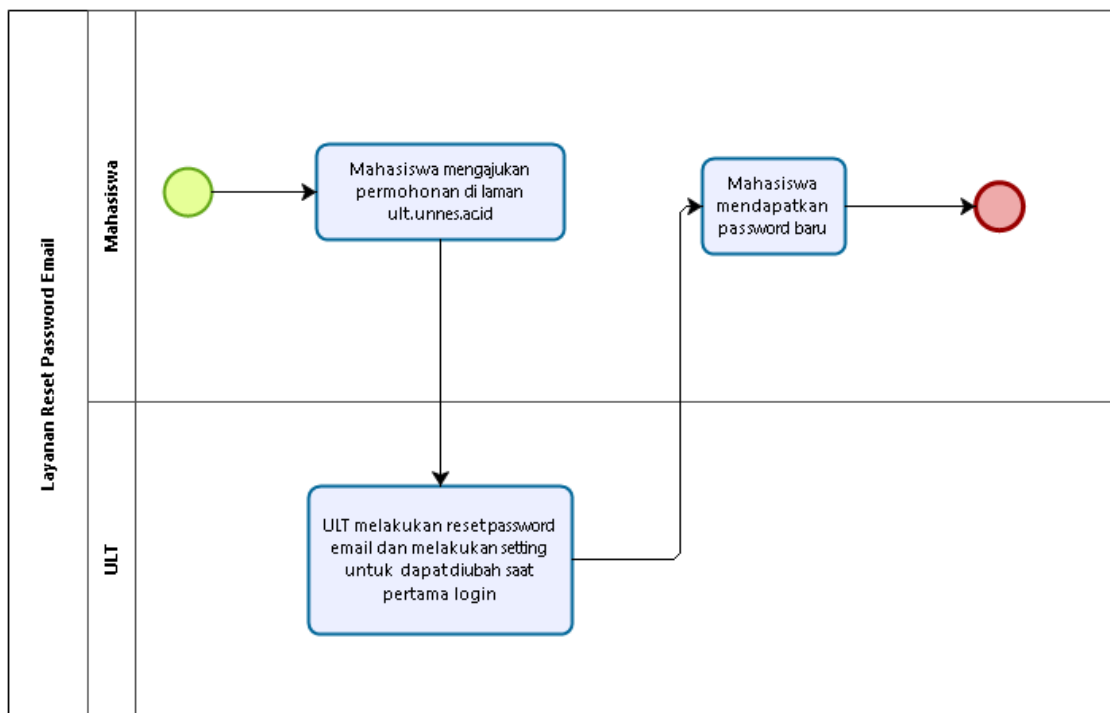

Powered by
bizagi
Modeler

Level 4 Layanan Pembatalan Validasi SITEDI

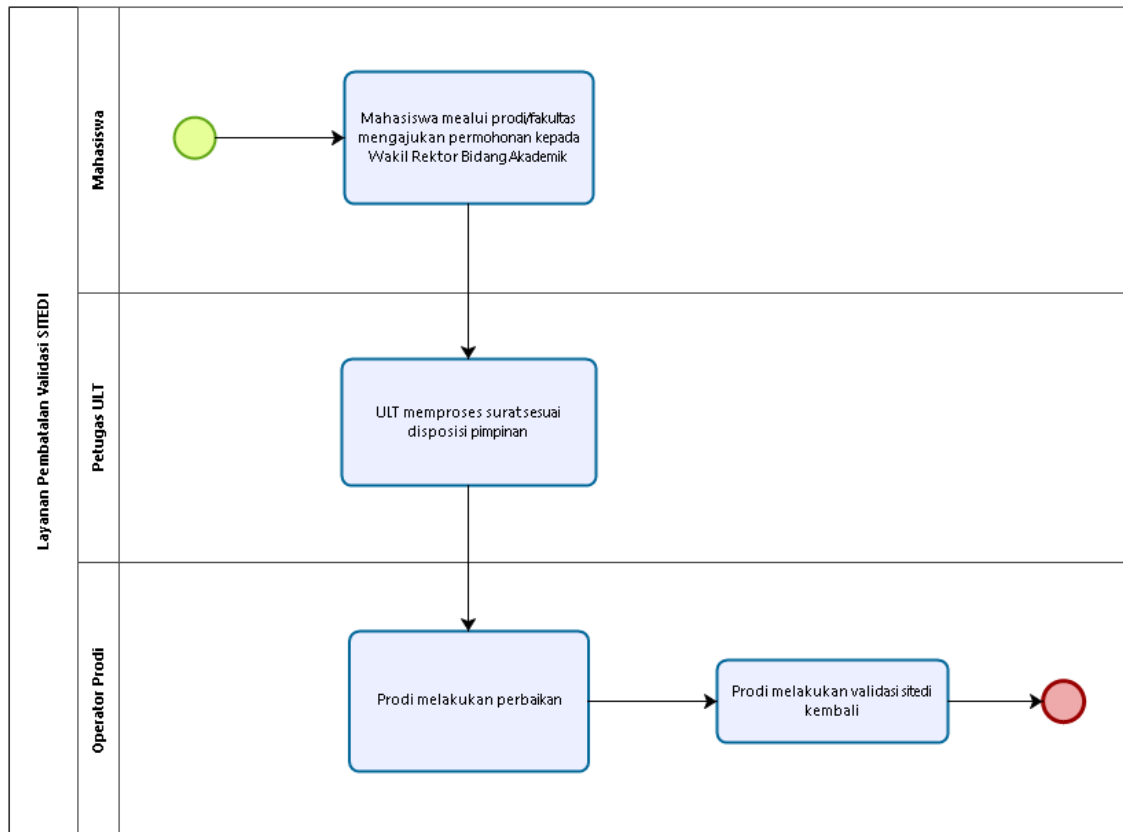

Level 4 Layanan Perpanjangan Pembayaran Cuti

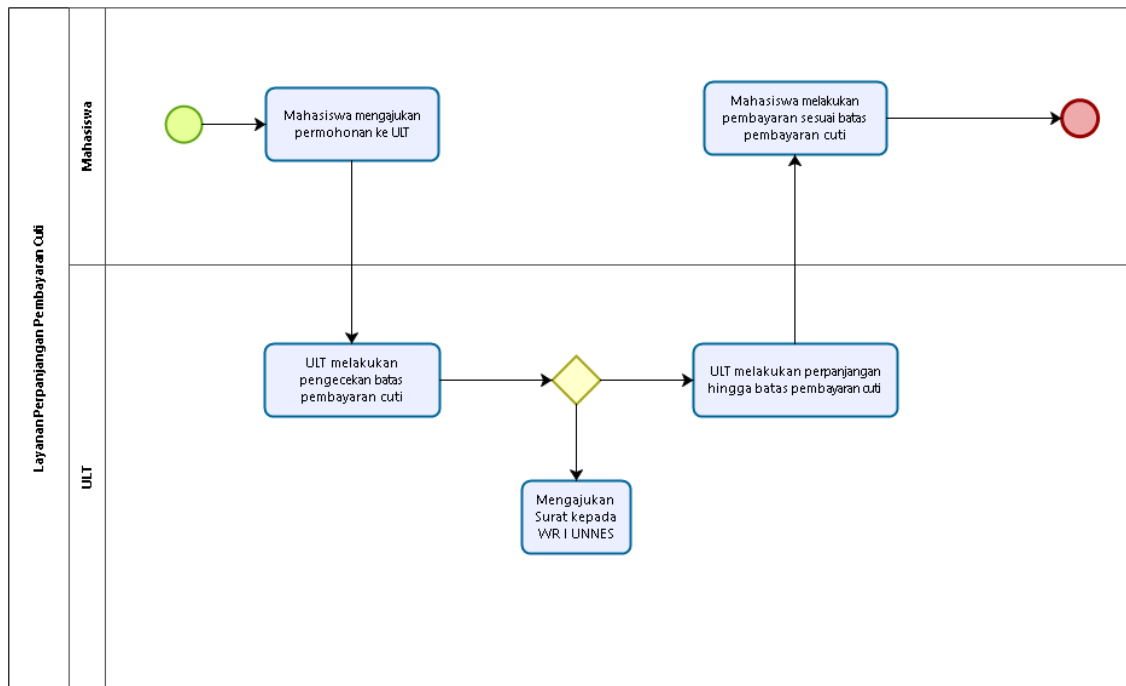

Powered by
bizagi
Modeler

Level 4 Layanan Pergantian Dosen Wali

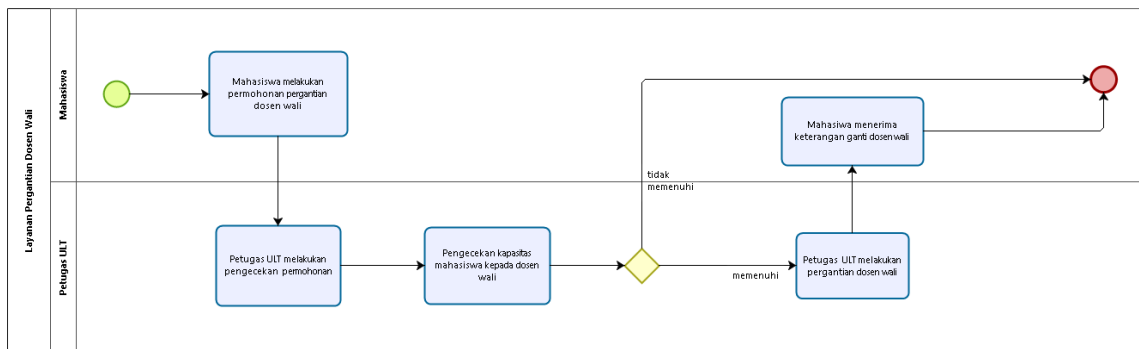

Powered by
bizagi
Modeler

Level 4 Layanan Cetak Ulang KTM

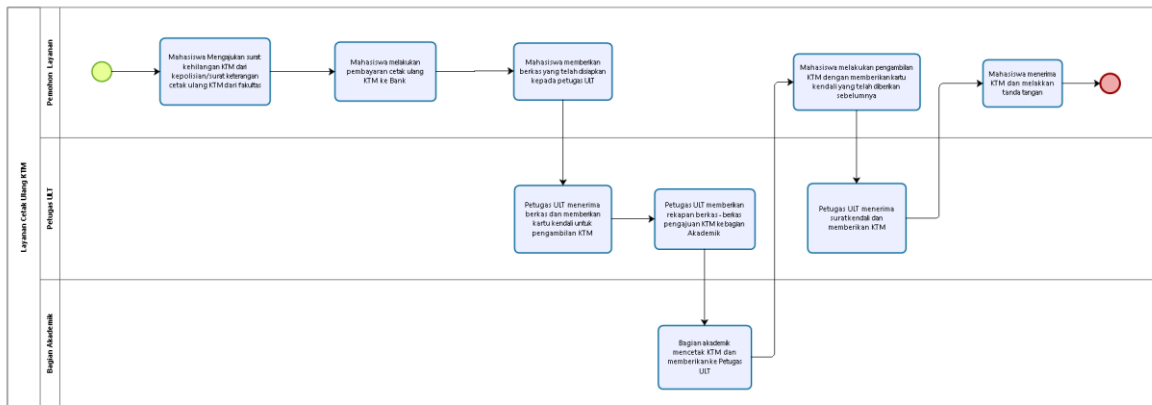

Level 4 Layanan Reset Siap Ujian

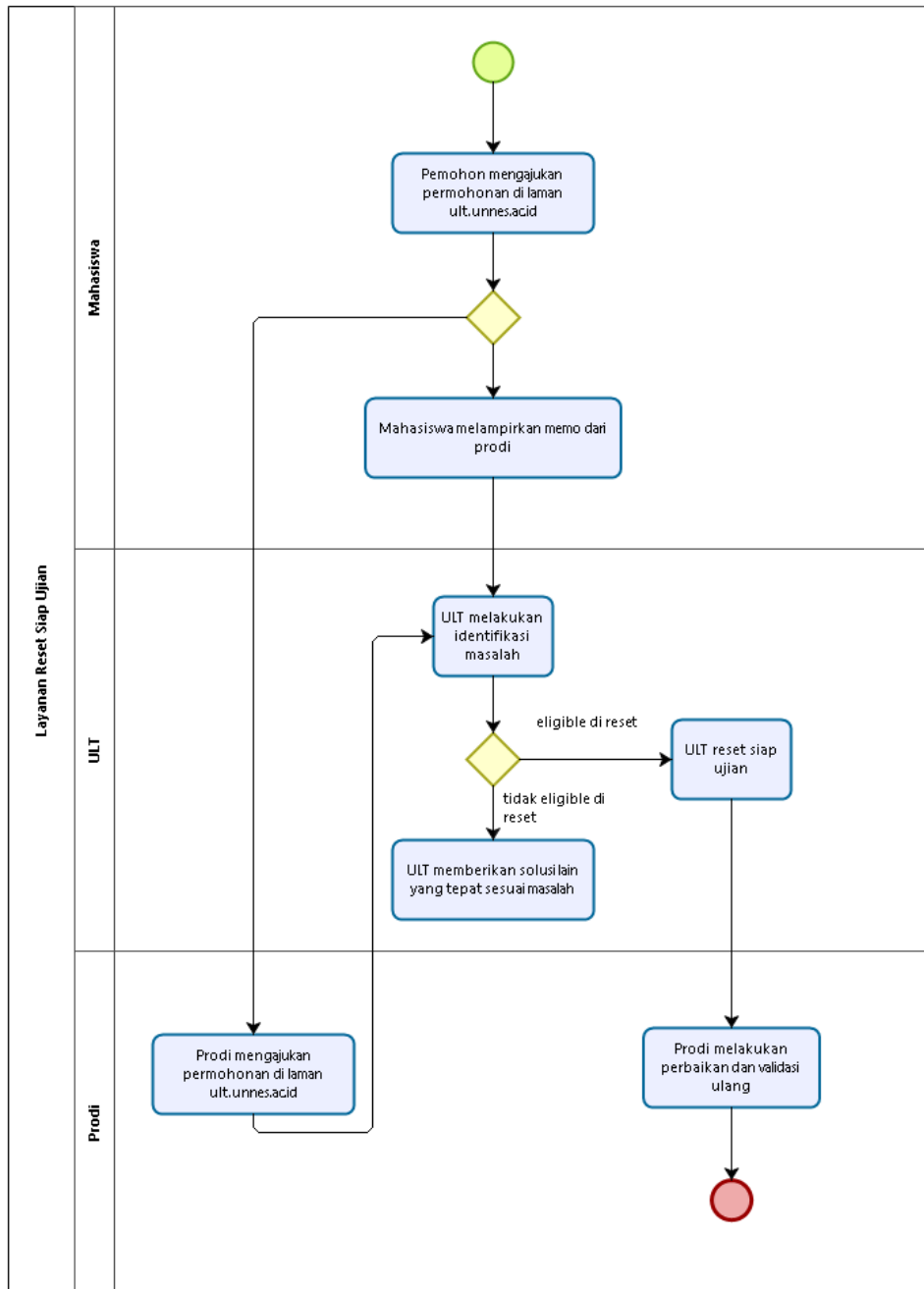

Level 4 Layanan Edit Biodata

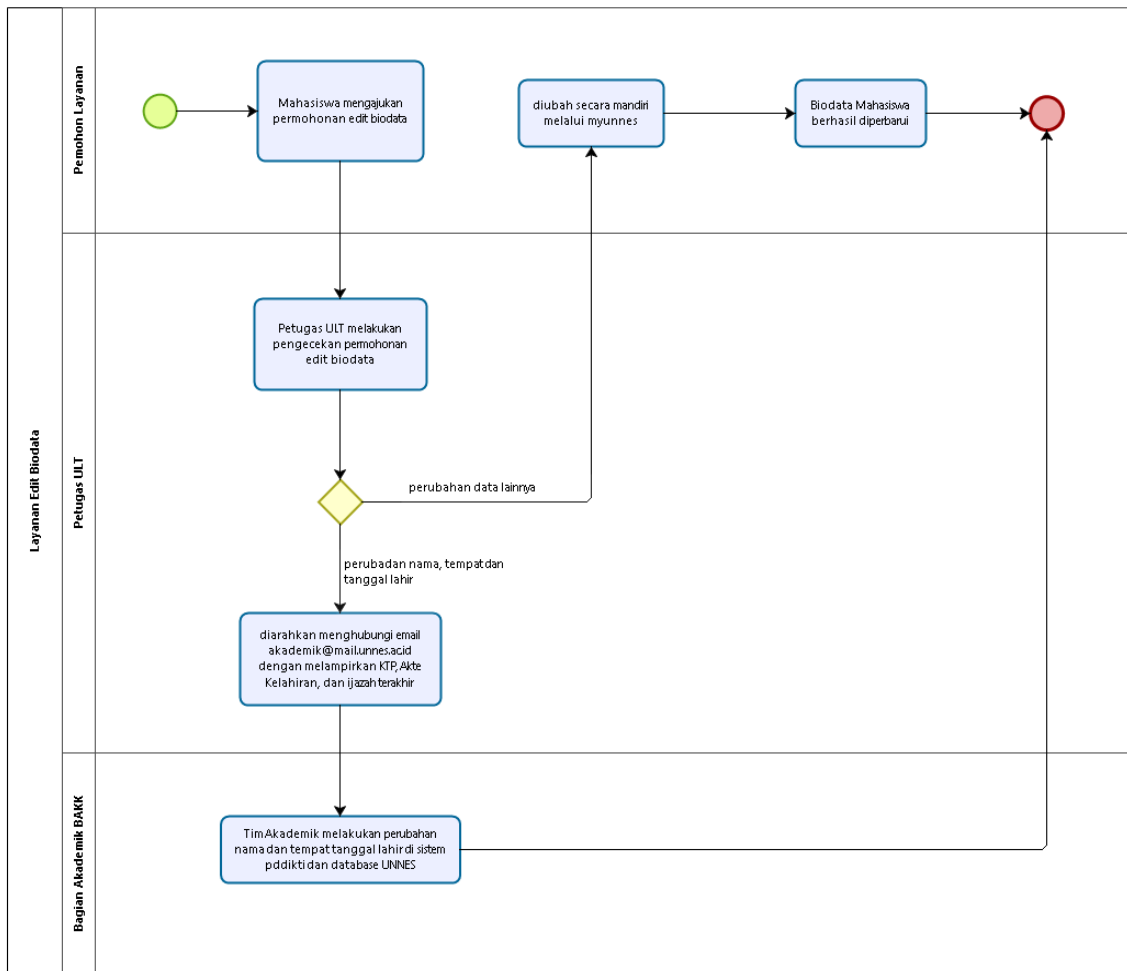

Level 4 Layanan Revisi Nilai Mahasiswa

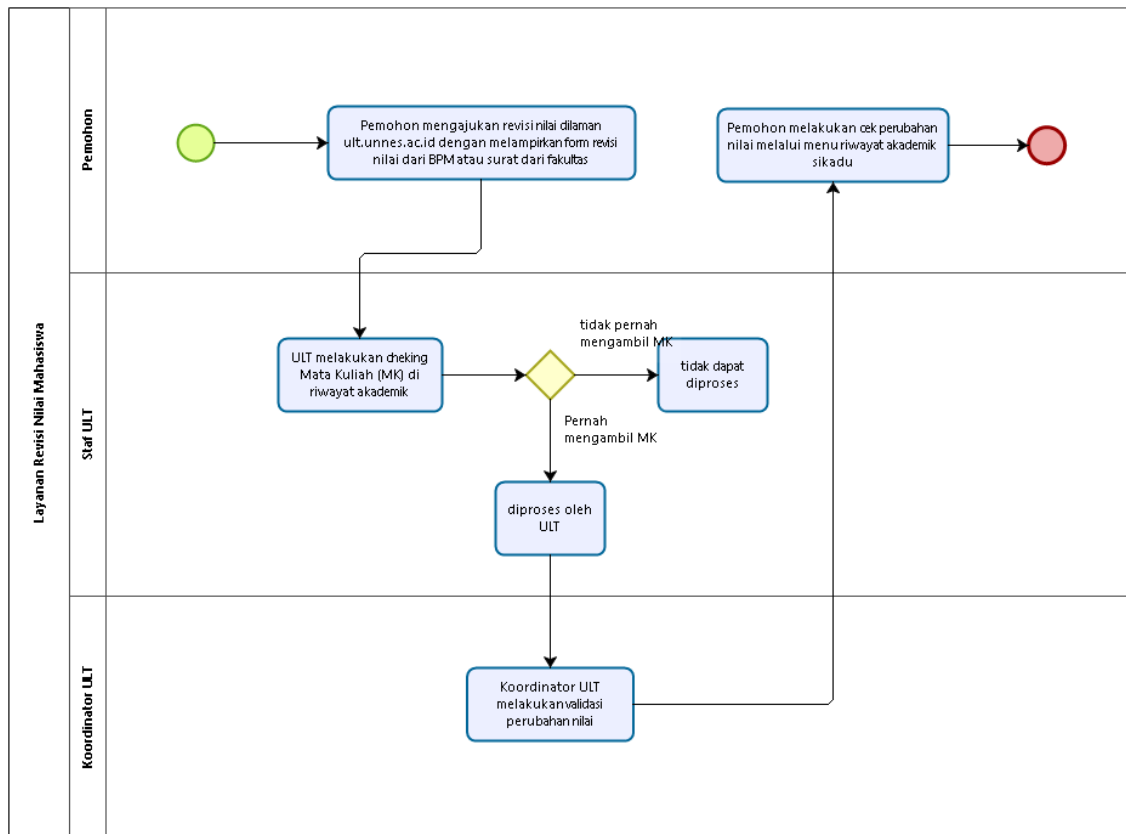

Level 4 Layanan Request Data

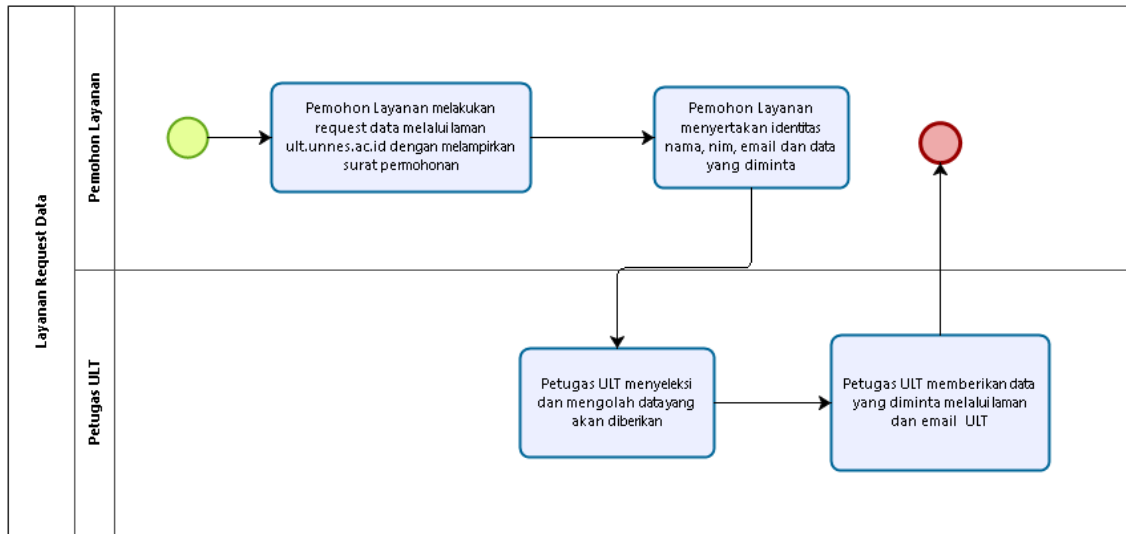

Level 4 Layanan Perbaikan Judul Skripsi / Tesis / Disertasi

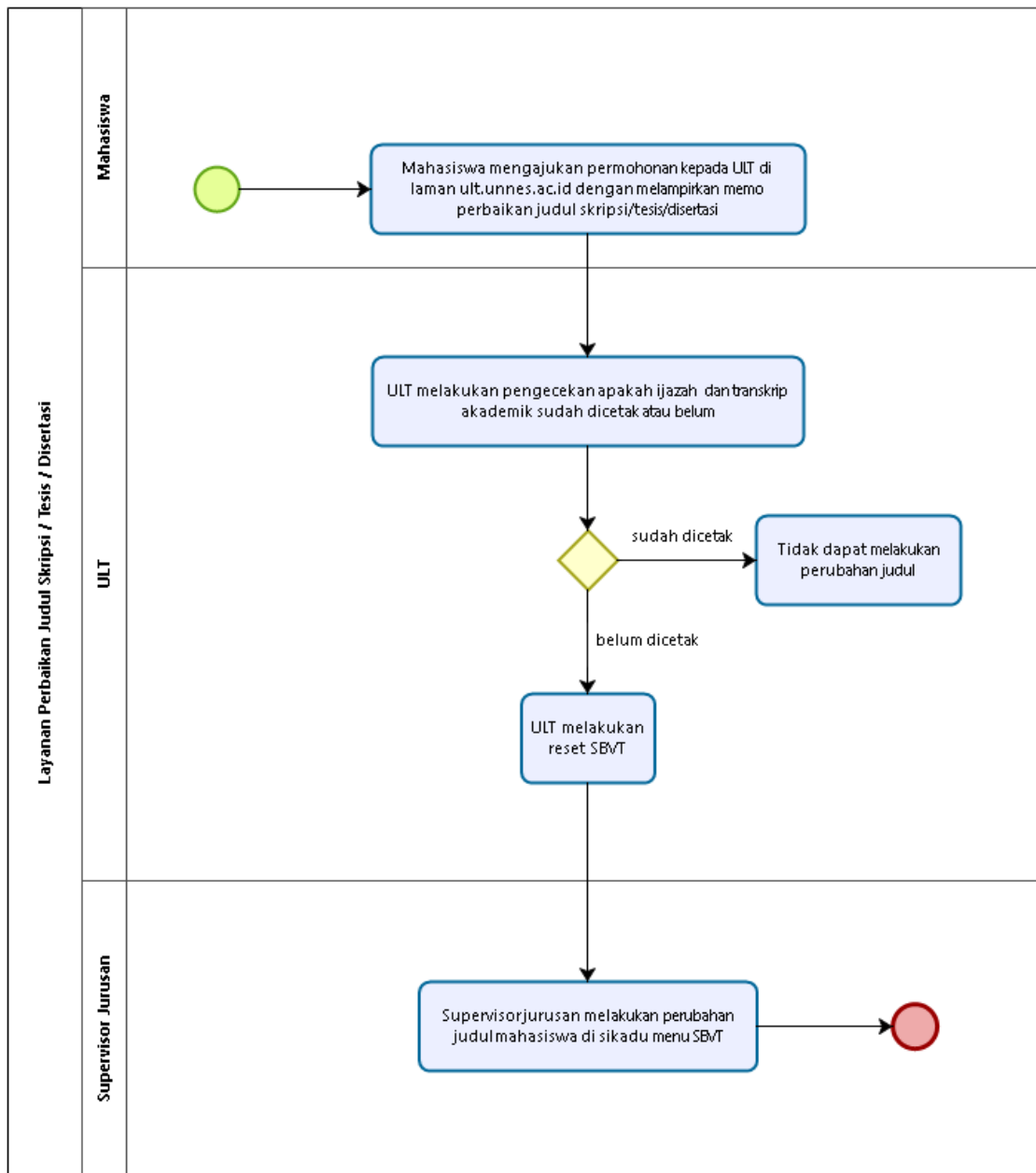

Level 4 Layanan Perbaikan Rencana Studi

